

TRIPLE ROLLER TUBE PAVERS

TRTP255T4



OPERATIONS & PARTS MANUAL

Manual Part #: 049307 | Revision: 05/2026
Language: English | Original Instructions



ALLEN
CONCRETE PAVERS

NOTICE

This manual, or a copy of it, must be kept with the machine at all times. There is a manual storage container located on the machine for your convenience.

Triple Roller Tube Paver

OPERATIONS-PARTS

MANUAL

Copyright © 2019 Allen Engineering Corporation
All rights reserved

All information, specifications, and illustrations in this manual are subject to change without notice and are based on the latest information at the time of publication. No part of this manual may be reproduced or transmitted in any form or by any means, electronics or mechanical, for any purpose, without the express written permission of Allen Engineering Corporation (AEC). AEC assumes no responsibility or liability for any errors or inaccuracies that may appear in this manual.

Allen® Products are covered under one or more of the following patent numbers:

U.S. Design Patents: 344,736; 400,542; 400,544; 402,998; 402,999; 403,332; 404,041; 404,042; 410,931; 413,127; 416,564; 465,897; 466,909; 474,203.

U.S. Utility Patents: 5,108,220; 5,238,323; 5,328,295; 5,352,063; 5,405,216; 5,476,342; 5,480,257; 5,480,258; 5,533,831; 5,562,361; 5,567,075; 5,613,801; 5,658,089; 5,685,667; 5,803,658; 5,816,739; 5,816,740; 5,890,833; 5,934,823; 5,967,696; 5,988,938; 5,988,939; 6,019,433; 6,019,545; 6,048,130; 6,053,660; 6,089,786; 6,106,193; 6,857,815; 5,288,166; 6,582,153 B1.

Canadian Patents: 2,039,893.

With other Patents Pending.

First Issue: August 15, 2008 - Amended: May 2018, MN 18-045, M. Wesley, March 2019, AW, Aug. 2022 MAK

AEC Manual Part No.: 049307

Printed in U.S.A.

I. LIMITED WARRANTY & LIMITATION OF LIABILITY

Allen Engineering Corporation ("Allen") warrants its products to be free of defects in material or workmanship for:

TWO YEARS FROM END USER'S DATE OF PURCHASE, SUBJECT TO THE EXCEPTIONS AND SHORTER WARRANTY PERIODS DESCRIBED HEREIN.

The warranty period begins on the date of purchase by the End User of the product. All warranty is based on the following limited warranty terms and conditions, including the disclaimer of all implied warranties of any type and the disclaimer of consequential damages.



1. Allen's obligation and liability under this warranty are limited to repairing or replacing parts if, after Allen's inspection, there is determined to be a defect in material or workmanship. Allen reserves the choice to repair or replace.
2. All warranty-related parts must be purchased in advance through an Allen dealer. The parts will be made available to the Allen Distributor, Dealer, or Rental Center from whom the End User purchased the product.
For machines being prepared, a warranty request form and/ or RGA request form must be submitted to AEC after the repairs are completed.
3. Replacement warranty parts, installed in the product, are warranted only for the remainder of the warranty period of the product as though they were the original parts.
4. BATTERY POWERED PRODUCTS ARE WARRANTED FOR ONE YEAR FROM END USER'S DATE OF PURCHASE.
5. Allen does not warranty engines or batteries. Engine warranty claims should be made directly to an authorized factory service center for the particular engine manufacturer. Batteries are not warranted due to unknown treatment during transport, etc., and any battery claims should be directed to the battery manufacturer.
6. Allen's warranty does not cover the normal maintenance of products or their components (such as engine tune-ups and oil & filter changes). The warranty also does not cover normal wear and tear items (such as belts, tires, blades, pans and other consumables).
7. Hydraulic Component's are required to be maintained per Allen's mandatory service intervals in each machines owners manual. OEM Allen hydraulic filters and consumables are required to service machines during the warranty period. Failure to use OEM Allen hydraulic filters will result in denied warranty.
8. Allen's warranty will be void if it is determined that the defect resulted from operator abuse, failure to perform normal maintenance on the product, modification to product, alterations, or repairs made to the product without the written approval of Allen. Allen specifically excludes from warranty any damage to any trowels resulting from a drop or impact to the rotors.
9. Impact damage to gearboxes is not covered under the Allen warranty and is deemed customer abuse.
10. Impact damage to trowels in any way is not covered under the Allen Warranty and is deemed customer abuse. (Example: Dropping a machine)
11. Allen will pay shop labor on warranty items at the Allen Shop Labor Rate in existence on the date of the warranty claim. An Allen labor chart will determine the time allowed to complete a repair and will govern the shop labor hours that will be allowed.
12. Allen will credit the cost of ground freight on warranty replacement parts after approval of the warranty claim. No warranty replacement parts will be shipped air-freight at the expense of Allen. Allen does not pay any inbound freight.
13. ALLEN ENGINEERING CORPORATION'S WARRANTY POLICY WILL NOT COVER THE FOLLOWING: TAXES; SHOP SUPPLIES; ENVIRONMENTAL SURCHARGES; AIR FREIGHT; TRAVEL TIME; LOSS OF TIME; INCONVENIENCE; LOSS OF RENTAL REVENUE; RENTAL COSTS OF EQUIPMENT USED TO REPLACE THE PRODUCT BEING REPAIRED; LOSS OF USE OF THE PRODUCT; COMMERCIAL LOSS; OR ANY OTHER CHARGES WHATSOEVER OR ANY LIABILITIES FOR DIRECT, INCIDENTAL, OR CONSEQUENTIAL DAMAGE OR DELAY.
14. ALLEN ENGINEERING CORPORATION MAKES NO OTHER WARRANTY, EXPRESSED OR IMPLIED. THIS LIMITED WARRANTY IS IN LIEU OF THE WARRANTY OF MERCHANTABILITY AND FITNESS. THERE ARE NO OTHER WARRANTIES THAT EXTEND BEYOND THE DESCRIPTION ON THIS DOCUMENT.
15. No Allen employee or representative is authorized to change this warranty in any way or grant any other warranty unless such change is made in writing and signed by an officer of Allen Engineering Corporation.
16. Warranty claims must be submitted within 30 days from the date of failure.
17. Once a warranty claim has been submitted, AEC has up to 90 business days to process the request.
18. Standard service part warranty will not exceed 90 days from the date of purchase. Exceptions to this are:
#1 Gearboxes: 1year warranty from date of purchase.
#2 Electrical Components: 30 day warranty from date of purchase. This applies to wiring harnesses, transmitters, ECUs, display screens, and toggle switches.
19. All purchased components are subject to the inspection and warranty of the respective manufacturer. This inspection may extend beyond 90 days.
20. If warranty is suspected do not disassemble any hydraulic or electrical components. Failure to comply with this instruction will lead to denial of a warranty claim.

Table of Contents

Sect No.	Title	Page
...	Limited Warranty	ii
...	Information Contained In This Manual	v
...	Dealer Information	vi
...	Ordering Parts	vii
...	Model Number - Serial Number Codes	viii
...	Unit Identification	ix
...	Technical specifications	x
...	Engine Specifications	xvi
...	Machine Dimensional Specifications	xiii
1.0	Safety	1-1
...	State Regulations	1-2
...	Federal Regulations	1-3
1.1	General Safety Precautions	1-4
1.2	Operating Safety	1-6
1.3	Engine Safety	1-8
1.4	Servicing Safety	1-9
1.5	Safety And Operation Labels	1-10
1.6	Notes	???
2.0	Operations	2-1
2.1	Introduction	2-3
2.2	Start Up Procedures	2-4
2.3	Operating Instructions	2-6
2.4	Changing Machine Length	???
2.5	Loading Instructions	???
3.0	Service	3-1
3.1	Periodic Maintenance Schedule	3-2
3.2	Bearings	3-3
3.3	Tube Greasing	3-4
3.4	Spray Nozzles	3-5
3.5	Inline Spray Filter	3-6
3.6	Air Breather	3-7
3.7	Fuel Filter	3-8
3.8	Hinge Pin	3-9
4.0	Parts	4-1

Table of Contents, continued

...	Factory Service Information	4-2
...	Replacement Part Procedure	4-3
4.1	Power Unit Assembly	4-4 thru 4-5
4.2	Motor End Assembly	4-6 thru 4-11
4.3	Idle End Assembly	4-12 thru 4-13
4.4	Spray Bar Assembly	4-14 thru 4-15
4.5	Frame Assembly	4-16 thru 4-17
4.6	Scraper Assembly	4-18 thru 4-21
4.7	Front Walkway Assembly	4-22 thru 4-23
4.8	Rear Walkway Assembly	4-24 thru 4-25
4.9	Ballast Tube Assembly	4-26 thru 4-27
4.10	Hydraulic Schematic	4-28 thru 4-29
4.11	Wiring Schematic	4-30 thru 4-31
4.12	Idle End Grease Fittings (Oct 2014)	4-32 thru 4-33
4.13	Spray System Schematic	4-46
5.0	Vibration	
	Table of Contents	5-2
	Vibration Operation	5-3
5.1	Butterfly Assembly	5-4
5.2	Vibrator Assembly	5-5
5.3	Vibrator Rack Assembly	5-8
5.4	Vibration Rack Matrix	5-9
5.5	Vibrator Shaft Assembly	5-10
5.6	Motor End Assembly	5-12
5.7	Idle End Assembly	5-14
5.8	Gang Vibration Parts	5-16
5.9	Electrical Schematics	5-18
5.10	Hydraulic Schematics	5-20
6.0	Hatz Diesel Engine Amendment	
	Engine Specifications	6-2
	Hatz Declaration of Comfomity	6-9
	Maintenance Schedule	6-10
	Filter Replacement	6-13
	Troubleshooting	6-19
	Engine Parts	6-21
	End Frame Assembly	6-23

Information Contained in this Manual



This manual provides information and procedures to safely operate and maintain the Allen Concrete Paver Machine.

For your own safety and protection from personal injury, carefully read, understand, and observe the safety instructions described in this manual. Keep this manual or a copy of it with the machine at all times.

Always operate this machine in accordance with the instructions described in this manual. A well maintained piece of equipment will provide many years of trouble free operation.

This manual is divided into the following sections:

**SECTION 1
SAFETY**

**SECTION 4
PARTS**

**SECTION 2
OPERATIONS**

**SECTION 5
VIBRATION**

**SECTION 3
SERVICE**

Complete any warranty requirements as specified by the engine manufacturer in their instructions found inside the manual box located on the back of the riding trowel operator's seat.

Your engine is not manufactured by Allen Engineering Corporation, Inc, and therefore is not covered under Allen Engineering Corporation, Inc warranty.

Your engine manufacturer should be contacted if you wish to purchase a parts manual or a repair manual for your engine.

Refer to enclosed owners engine manual for complete O&M instructions. See your battery manufacturer for battery warranty.

Dealer Information

Your Dealer has Allen Engineering Corporation trained mechanics and original Allen replacement parts. Always contact the Allen Dealer who sold you this machine for Allen Certified repairs and replacement parts.

Place Allen Dealer information below for future reference:

Dealer Name: _____

Phone #: (____) - ____ - _____

Address: _____

City: _____ **State:** _____ **Zip:** _____

Salesman: _____ **Mobile Phone** _____

Additional Comments: _____

Ordering Parts

Section 4.0 contains illustrated parts lists for help in ordering replacement parts for your machine. Follow the instructions below when ordering parts to insure prompt and accurate delivery:

1. All orders for service parts - include the serial number for the machine. Shipment will be delayed if this information is not available.
2. Include correct description and part number from the "PARTS" section of this manual.
3. Specify exact shipping instructions, including the preferred routing and complete destination address.
4. **DO NOT** return parts to AEC without receiving written authorization from AEC. All authorized returns must be shipped pre-paid.
5. When placing an order, please contact the AEC dealer nearest you.



All information, specifications, and illustrations in this manual are subject to change without notice and are based on the latest information at the time of publication.

Model Number - Serial Number Codes

Manufacturer's Codes:

When ordering parts or requesting service information, you will always be asked to specify the model and serial numbers of the machine. The legends below specifically defines each significant character or group of characters of the Model Number and Serial Number codes.

Model Number

T255CD

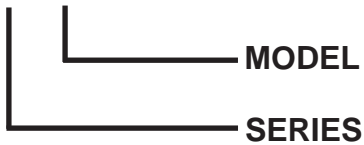

Serial Number

The serial number found on the identification plate is a ten digit format. The model number identifies your machine and will ensure that you receive the correct replacement parts.

T255 08 07 47



Unit Identification

Unit Identification Plate Location:

An identification plate listing the model number and the serial number is attached to each unit and is located on the rear lower left side of mainframe. Refer to Figure 1 for serial number and model number location. This plate should not be removed at any time.

Please record the information found on this plate below so it will be available should the identification plate become lost or damaged. When ordering parts or requesting service information, you will always be asked to specify the model and serial numbers of the machine.

FILL IN FOR FUTURE REFERENCE

Model Number:	_____
Serial Number:	_____
Date Purchased:	_____
Purchased From:	_____

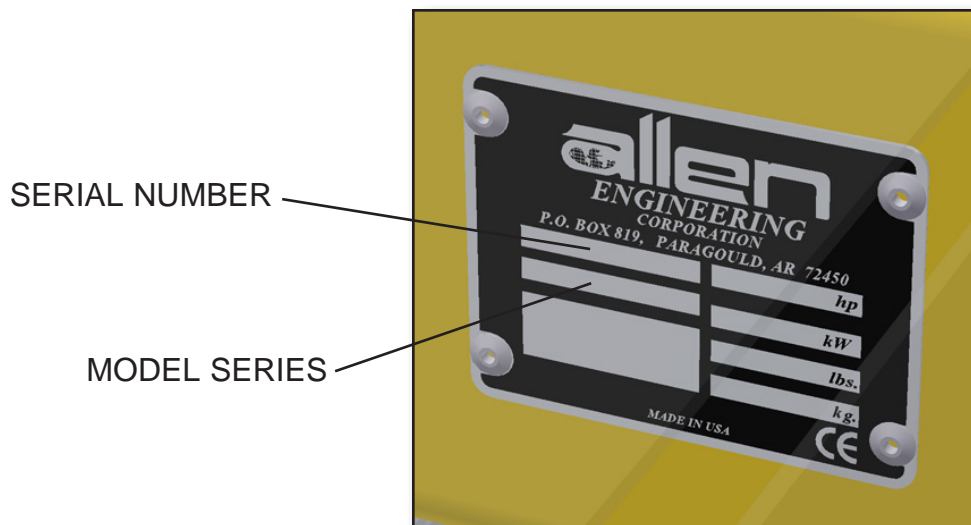

Figure 1
Serial Number Location

Technical Specifications

Measurements in this manual are in U.S. units and their customary metric units (i.e., metric units contained within brackets [8 mm]).

Machine Features:

ENGINE:

- Hydraulic Oil Reservoir25 Gallons (94.6L)
 - Fuel Reservoir10 Gallons (37.85L)
 - Direct drive hydraulic pump system?Yes
 - Machine widths available in 2' increments12' to 34' (3.66M to 10.37M)
 - Total machine weight at 22'5,570 lbs (2526.5kg)
- (weight will vary depending on machine width and optional accessories)

HYDRAULIC DRIVES:

- Direct spline drive to each tube?Yes
- Individual control for travel and screeding tubes?Yes
- Variable speed controls?Yes

SCREEDING TUBE:

- Direct drive forward and reverse?Yes
- Speed from 0 to 180 RPM?Yes

DRIVE TUBES:

- Direct drive to each tube?Yes
- Variable speed forward and reverse 0' to 25' per minute?Yes
- Drive tube scrapersStandard
- Heavy duty alloy steel octagonal drivers with spline motor connectors on all tubes?Yes

ROLLER TUBES:

- Diameter10" (255mm)
- Wall Thickness25" (6.35mm)
- Tube weight per foot27 lbs (12.2kg)
- Water Ballast available?Yes
- Operator Platform Standard?Yes
- Idle end counter weight?Yes
- Sectionalized overhead?Yes

SPRAY SYSTEMS:

- Hydraulic spray system (50 gallon water tank)Standard

Technical Specifications, continued

STEERING LEG:

Hydraulic Steering LegStandard

WALKWAYS:

Front Walkway.....Optional

Rear Walkway.....Optional

Counter balance tube (must have rear walkway)Optional

OPTIONS:

Manual crown kit.....Optional

Full width vibration.....Optional

Edge form vibration.....Optional

Engine Specifications

Engine Make & Model	Kubota 44HP V1505-TD
Gross Intermittent output.	kW(HP)/rpm 33.0(44.2)/3,000
Net Continuous output.	kW(HP)/rpm 27.2(36.5)/3,000
Fuel and type.	Diesel, No. 2-D (ASTM D975)
Cylinder arrangement	1-2-3
Bore x Stroke.	mm x mm 74 x 78.4
Total piston displacement	cc. 1,498
Compression ratio	22.5:1
Length x width x height (standard model).	mm 591.3 x 439.2 x 631.3
Dry weight (standard model).	kg/lb. 114/251.3

Machine Dimensional Specifications

All information, specifications, and illustrations on this page in this manual are subject to change without notice and are based on the latest information at the time of publication.

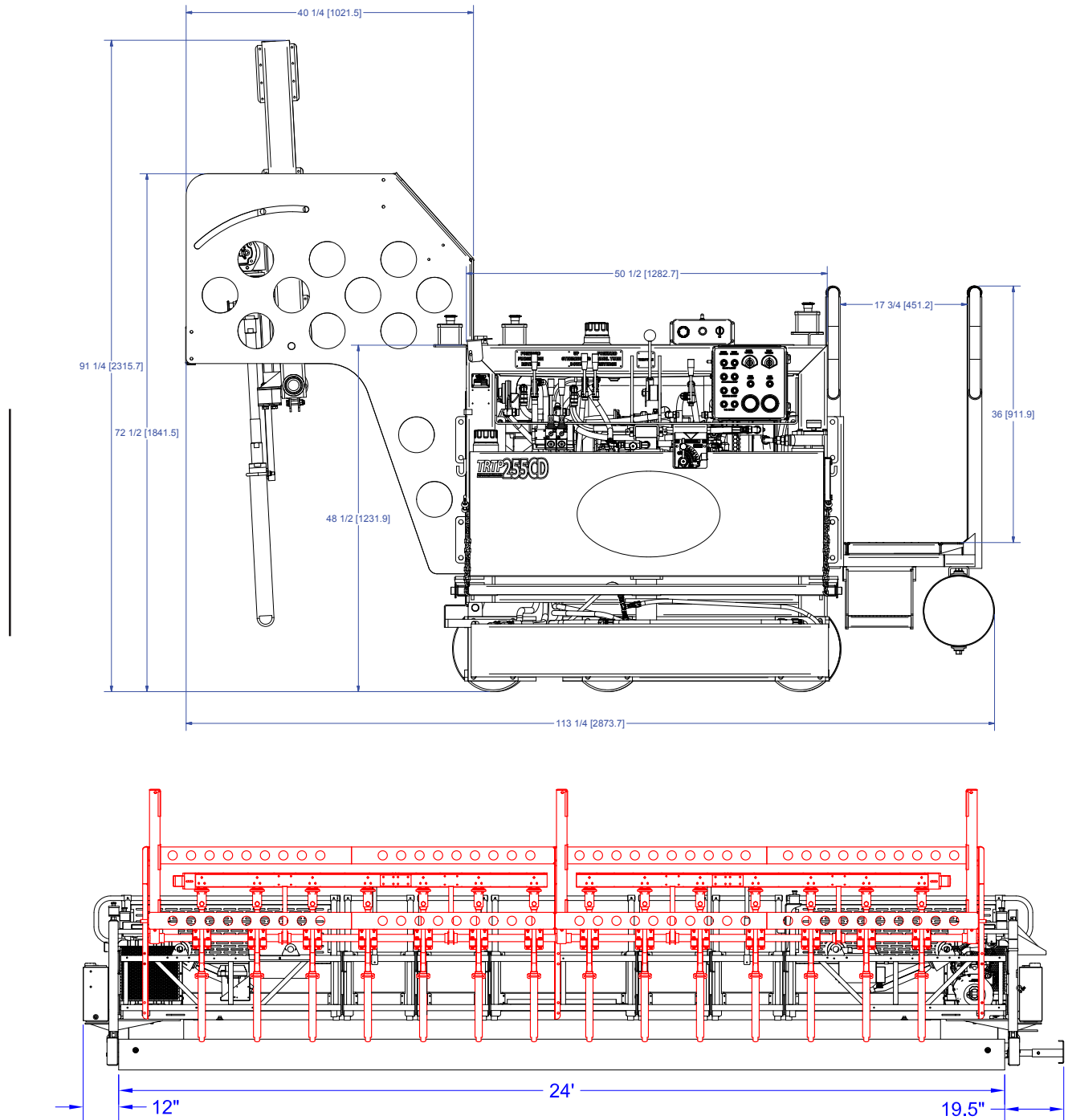

As the angle between each leg of a sling increases, the load on each leg increases. The effect is the same whether a single sling is being used as a basket, or two / three slings are being used in a straight pull.

This illustration shows the increased load on a sling leg when lifting a load with angled slings.

Sling Angle Factor

The Sling Angle Factor is a multiplier used to determine the required sling size when angle formed between sling and load is less than 90°.

Need to estimate angle to nearest 5°

Avoid rigging loads where angle is less than 45°

Sling angle	Load angle factor
90°	1.000
85°	1.004
80°	1.015
75°	1.035
70°	1.064
65°	1.103
60°	1.155
55°	1.221
50°	1.305
45°	1.414
40°	1.555
35°	1.742
30°	2.000
25°	2.366
20°	2.924
15°	3.864
10°	5.759
5°	11.47

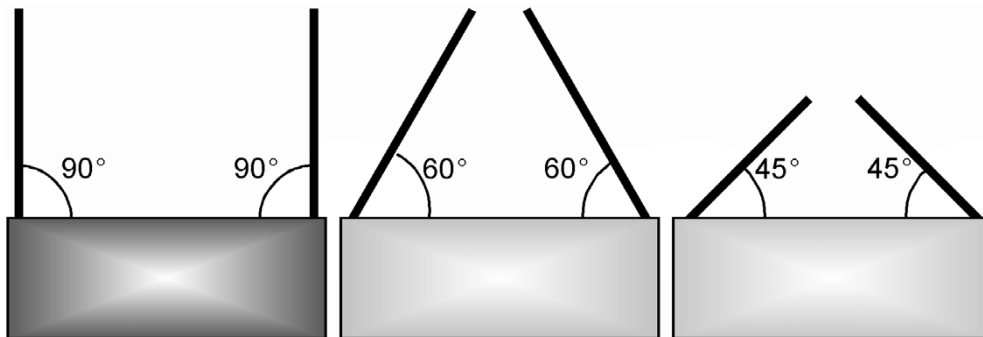

For all lifts, straight pulls or angled lifts, a Riggers Chart must be consulted. With multiple sling lifts the chart will be used to determine the load that each leg can support safely. Determining load on each leg of a multi-leg lift:

- Divide the total load by the number of legs. This provides the lift per leg if the lift were to be a straight pull.
- Determine the angle between the legs of the sling. - When three or more legs will be used, the angle will be twice the angle between one leg and an imaginary line straight down from the lifting hook.
- Multiply the load per leg by the load factor for each leg angle being used. See “computing the load on the legs of a sling” on the Riggers Chart. This will give you the ACTUAL load on each leg.

The actual load must not exceed the rated sling capacity of any sling leg.

Hooks

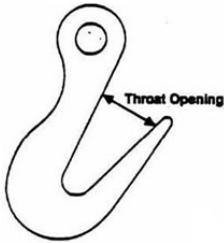
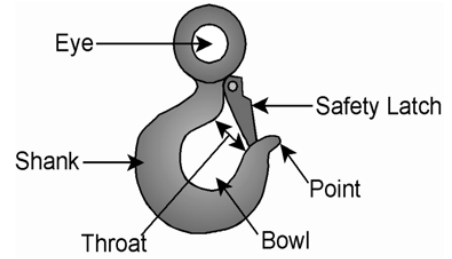

Sorting Hook



Eye Hook



Clevis Grab Hook



Choker Hook

**Eye Hook Rated Capacity Table
(Forged Alloy Steel)**

Throat Opening	Safe Working Limit (SWL, in pounds)
5/8	600
11/16	800
1	1500
1-1/16	2000
1-1/4	4000
1-3/8	4500
1-13/32	5000
1-1/2	5500
1-17/32	6000

Incorrect Hook Connections

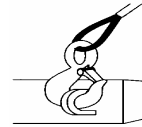

Side load

Back load

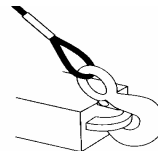
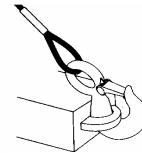

Point load

Hook Pre-Use Inspection Checklist

Inspect hooks daily before use and frequently during use. Remove from service when any of the following conditions exist:

- Missing or illegible manufacturer identification
- Cracks, nicks, or gouges
- Damage from heat
- Unauthorized repairs
- Improper operation and locking of self-locking hooks
- Any twist from plane of an bent hook
- Distortion or wear – any increase in throat opening of 5% not to exceed 1/4 inch, or wear exceeding 10% of original dimension

For added safety, hooks must be equipped with a latch or the throat opening closed-off/secured with a mouse. The latch or mouse is **not** intended to support the load.

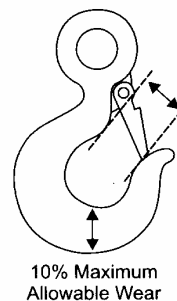

5% not to exceed 1/4 in.

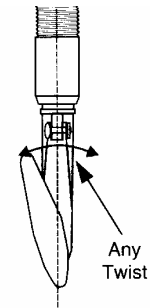

Shackles

Shackle Capacity Table (Forged with Alloy Pins)

Nominal Shackle Size	Rated Capacity (Pounds)
3/16	660
1/4	1000
5/16	1500
3/8	2000
7/16	3000
1/2	4000
5/8	6500
3/4	9500
7/8	13000
1	17000
1 1/8	19000
1 1/4	24000
1 3/8	27000
1 1/2	34000
2 1/2	110000

- If different from capacities listed above, use rated capacity marked on the shackle.
- If capacity marking is absent, shackle should be removed from service.

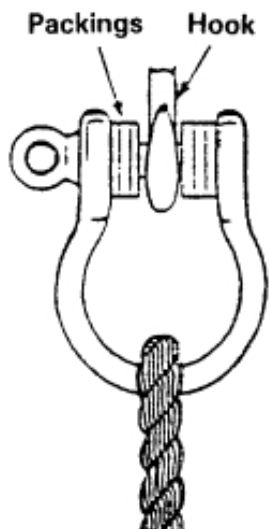
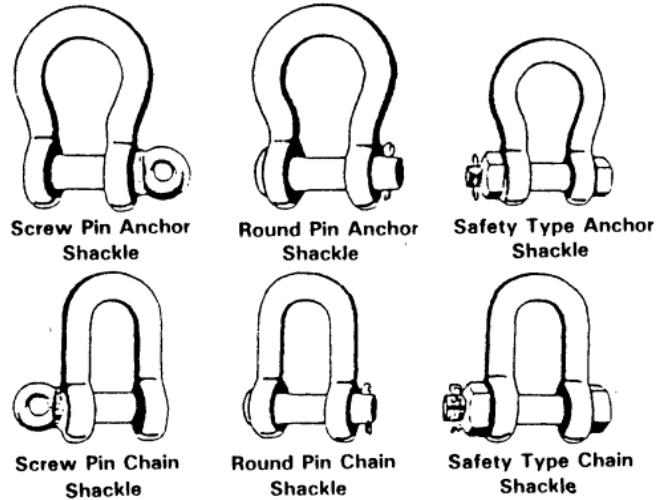

Good Practice
Pack the Pin
with Washers
to Centralize
the Shackle

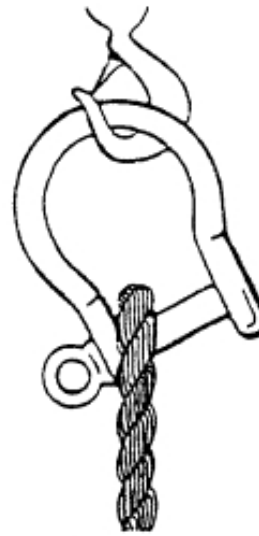

Poor Practice
Never Allow Shackle
to be Pulled at an
Angle, the Legs
will Open Up

Shackle Pre-Use Inspection Checklist

Inspect shackles daily before use and frequently during use.

- Each shackle body shall have forged, cast, or die stamped markings by the manufacture showing: name or trademark of the manufacturer, rated load/capacity (WLL or SWL), and size. This information shall not be missing and must be legible.



Remove from service when any of the following conditions exist:

- Indications of heat damage including weld spatter or arc strikes
- Excessive pitting or corrosion
- 10% reduction of the original or catalog dimension at any point around the body or pin
- Body spread including: bent, twisted, distorted, stretched, elongated, cracked, or broken load-bearing components
- Excessive nicks or gouges
- Incomplete pin engagement, shoulder of pin is not flush with shackle body
- Excessive thread damage
- Evidence of unauthorized welding

Never Replace a Shackle Pin with a Bolt

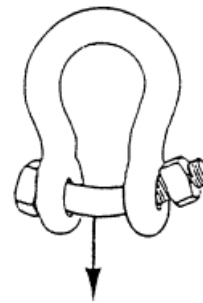

The Load will Bend the Bolt

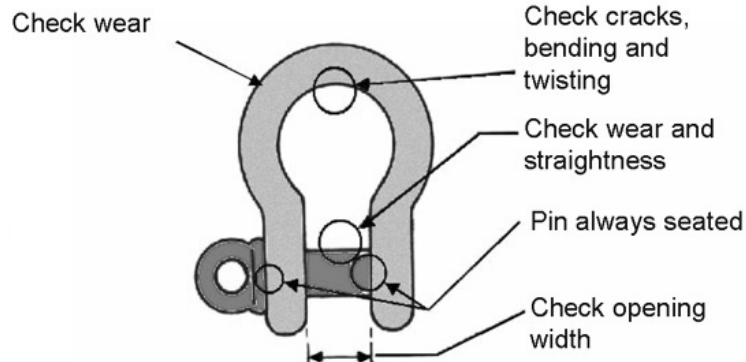

Incorrect Applications

Side Loading Reduction Factors Screw Pin and Bolt Type Shackles		
	Angle of Side Load from Vertical In-Line of Shackle	Percent Rated Load Reduction
	0° - 5°	0%
	5° - 45°	30%
	46° - 90°	50%
	Over 90°	Avoid

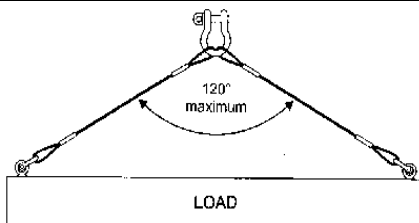

The rated capacity of shackles only applies when they are symmetrically loaded and the included angle between two sling legs is a maximum of 120°. Shackle capacity must be reduced when the angle is greater than 120°.



Lifting Slings - Minimum Capacity: 10,000lbs Each

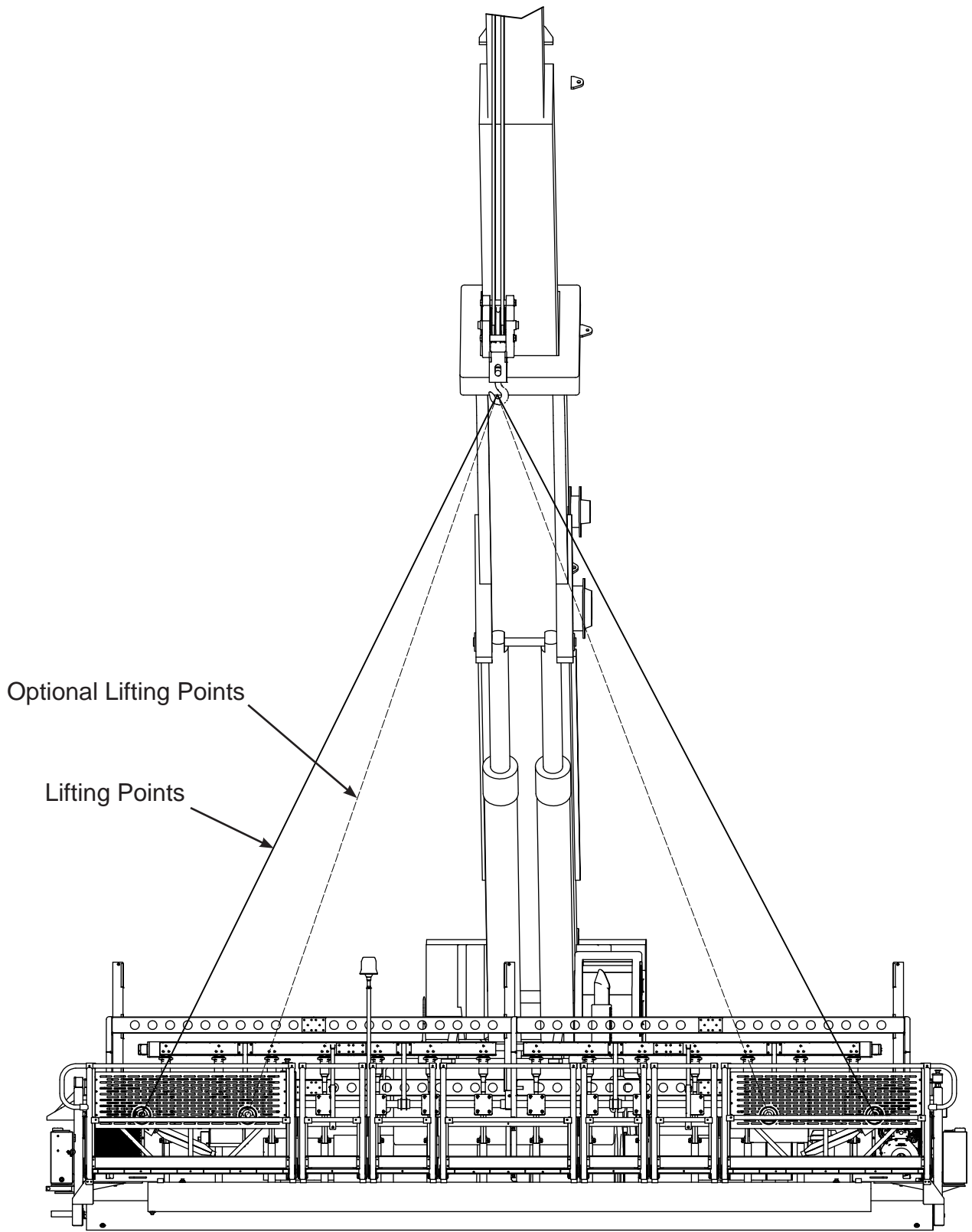

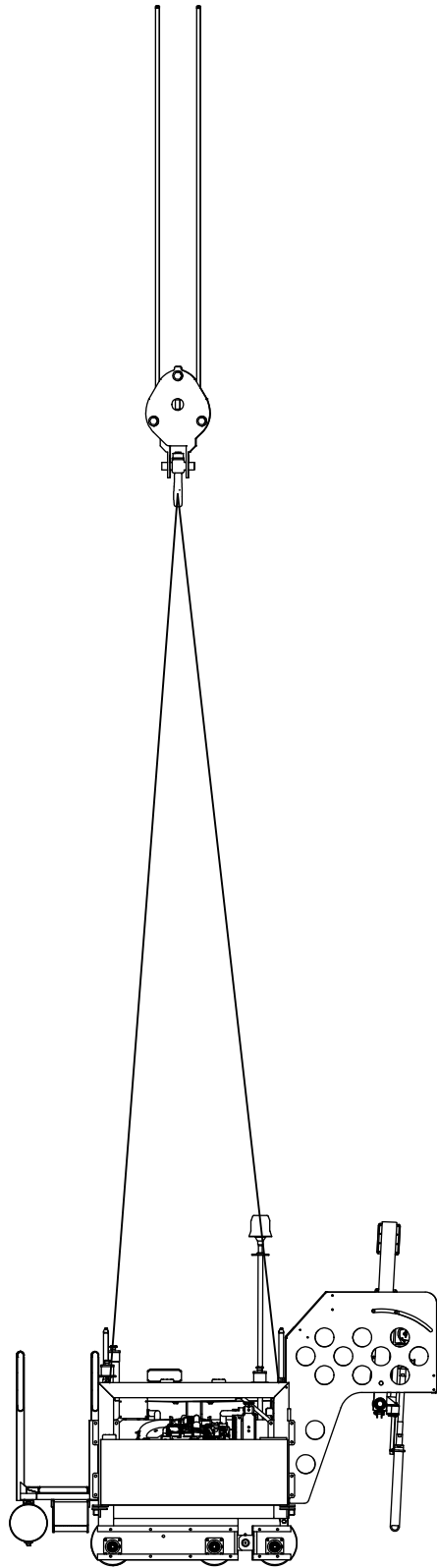

SAFETY DATA SHEET

CITGO A/W Hydraulic Oil 46



Section 1. Identification

GHS product identifier	: CITGO A/W Hydraulic Oil 46
Synonyms	: Hydraulic Fluid
Code	: 633492001
Supplier's details	: CITGO Petroleum Corporation P.O. Box 4689 Houston, TX 77210 sdsvend@citgo.com
Emergency telephone number	: Technical Contact: (800) 248-4684 Medical Emergency: (832) 486-4700 CHEMTREC Emergency: (800) 424-9300 (United States Only)

Section 2. Hazards identification

OSHA/HCS status	: While this material is not considered hazardous by the OSHA Hazard Communication Standard (29 CFR 1910.1200), this SDS contains valuable information critical to the safe handling and proper use of the product. This SDS should be retained and available for employees and other users of this product.
Classification of the substance or mixture	: Not classified.
GHS label elements	
Signal word	: Warning
Hazard statements	: Injection under the skin can cause severe injury. Most damage occurs in the first few hours. Initial symptoms may be minimal.
Precautionary statements	
General	: Avoid contact with eyes, skin and clothing. MAY BE HARMFUL IF SWALLOWED. IF IN EYES: Rinse cautiously with water for several minutes. Do NOT induce vomiting. After handling, always wash hands thoroughly with soap and water. If you feel unwell, seek medical attention and show the label when possible. Keep out of reach of children.
Prevention	: Not applicable.
Response	: Not applicable.
Storage	: Store in a dry place and/or in closed container. Store in accordance with all local, regional, national and international regulations.
Disposal	: Dispose of contents and container in accordance with all local, regional, national and international regulations.
Hazards not otherwise classified	: Injection of petroleum hydrocarbons requires immediate medical attention

Section 3. Composition/information on ingredients

Substance/mixture	: Mixture
Other means of identification	: Hydraulic Fluid
CAS number/other identifiers	
CAS number	: Not applicable.

Section 3. Composition/information on ingredients

Any concentration shown as a range is to protect confidentiality or is due to process variation.

There are no ingredients present which, within the current knowledge of the supplier and in the concentrations applicable, are classified as hazardous to health or the environment and hence require reporting in this section.

Occupational exposure limits, if available, are listed in Section 8.

Section 4. First aid measures

Description of necessary first aid measures

- Eye contact** : Immediately flush eyes with plenty of water, occasionally lifting the upper and lower eyelids. Check for and remove any contact lenses. Get medical attention if irritation occurs.
- Inhalation** : Remove victim to fresh air and keep at rest in a position comfortable for breathing. Get medical attention if symptoms occur.
- Skin contact** : Flush contaminated skin with plenty of water. Remove contaminated clothing and shoes. Get medical attention if symptoms occur.
- Ingestion** : Wash out mouth with water. Remove victim to fresh air and keep at rest in a position comfortable for breathing. Do not induce vomiting unless directed to do so by medical personnel. Get medical attention if symptoms occur.

Most important symptoms/effects, acute

Potential acute health effects

- Eye contact** : No known significant effects or critical hazards.
- Inhalation** : No known significant effects or critical hazards.
- Skin contact** : Injection of pressurized hydrocarbons can cause severe permanent tissue damage. Initial symptoms may be minor.
- Ingestion** : No known significant effects or critical hazards.

Over-exposure signs/symptoms

- Eye contact** : No specific data.
- Inhalation** : No specific data.
- Skin contact** : No specific data.
- Ingestion** : No specific data.

Indication of immediate medical attention and special treatment needed, if necessary

- Notes to physician** : Treat symptomatically. Contact poison treatment specialist immediately if large quantities have been ingested or inhaled.
- Specific treatments** : Treat symptomatically and supportively.
- Protection of first-aiders** : No action shall be taken involving any personal risk or without suitable training.

See toxicological information (Section 11)

Section 5. Fire-fighting measures

- Specific hazards arising from the chemical** : In a fire or if heated, a pressure increase will occur and the container may burst.

Extinguishing media

- Suitable extinguishing media** : Use an extinguishing agent suitable for the surrounding fire.
- Unsuitable extinguishing media** : None known.
- Hazardous thermal decomposition products** : Decomposition products may include the following materials:
carbon dioxide
carbon monoxide

Section 5. Fire-fighting measures

- Special protective actions for fire-fighters** : Promptly isolate the scene by removing all persons from the vicinity of the incident if there is a fire. No action shall be taken involving any personal risk or without suitable training.
- Special protective equipment for fire-fighters** : Fire-fighters should wear appropriate protective equipment and self-contained breathing apparatus (SCBA) with a full face-piece operated in positive pressure mode.

Section 6. Accidental release measures

Personal precautions, protective equipment and emergency procedures

- For non-emergency personnel** : No action shall be taken involving any personal risk or without suitable training. Evacuate surrounding areas. Keep unnecessary and unprotected personnel from entering. Do not touch or walk through spilled material. Put on appropriate personal protective equipment.
- For emergency responders** : If specialised clothing is required to deal with the spillage, take note of any information in Section 8 on suitable and unsuitable materials. See also the information in "For non-emergency personnel".
- Environmental precautions** : Avoid dispersal of spilled material and runoff and contact with soil, waterways, drains and sewers. Inform the relevant authorities if the product has caused environmental pollution (sewers, waterways, soil or air).

Methods and materials for containment and cleaning up

- Small spill** : Stop leak if without risk. Move containers from spill area. Dilute with water and mop up if water-soluble. Alternatively, or if water-insoluble, absorb with an inert dry material and place in an appropriate waste disposal container. Dispose of via a licensed waste disposal contractor.
- Large spill** : Stop leak if without risk. Move containers from spill area. Prevent entry into sewers, water courses, basements or confined areas. Wash spillages into an effluent treatment plant or proceed as follows. Contain and collect spillage with non-combustible, absorbent material e.g. sand, earth, vermiculite or diatomaceous earth and place in container for disposal according to local regulations (see Section 13). Dispose of via a licensed waste disposal contractor. Note: see Section 1 for emergency contact information and Section 13 for waste disposal.

Section 7. Handling and storage

Precautions for safe handling

- Protective measures** : Put on appropriate personal protective equipment (see Section 8).
- Advice on general occupational hygiene** : Eating, drinking and smoking should be prohibited in areas where this material is handled, stored and processed. Workers should wash hands and face before eating, drinking and smoking. Remove contaminated clothing and protective equipment before entering eating areas. See also Section 8 for additional information on hygiene measures.

- Conditions for safe storage, including any incompatibilities** : Store in accordance with local regulations. Store in original container protected from direct sunlight in a dry, cool and well-ventilated area, away from incompatible materials (see Section 10) and food and drink. Keep container tightly closed and sealed until ready for use. Containers that have been opened must be carefully resealed and kept upright to prevent leakage. Do not store in unlabeled containers. Use appropriate containment to avoid environmental contamination.

Bulk Storage Conditions: Maintain all storage tanks in accordance with applicable regulations. Use necessary controls to monitor tank inventories. Inspect all storage tanks on a periodic basis. Test tanks and associated piping for tightness. Maintain the automatic leak detection devices to assure proper working condition.

Section 8. Exposure controls/personal protection

Control parameters

Occupational exposure limits

None identified.

- Appropriate engineering controls** : Good general ventilation should be sufficient to control worker exposure to airborne contaminants.
- Environmental exposure controls** : Emissions from ventilation or work process equipment should be checked to ensure they comply with the requirements of environmental protection legislation. In some cases, vapor controls, filters or engineering modifications to the process equipment will be necessary to reduce emissions to acceptable levels.

Individual protection measures

- Hygiene measures** : Wash hands, forearms and face thoroughly after handling chemical products, before eating, smoking and using the lavatory and at the end of the working period. Appropriate techniques should be used to remove potentially contaminated clothing. Wash contaminated clothing before reusing. Ensure that eyewash stations and safety showers are close to the workstation location.
- Eye/face protection** : Safety glasses equipped with side shields are recommended as minimum protection in industrial settings. If contact is possible, the following protection should be worn, unless the assessment indicates a higher degree of protection: Splash goggles. Safety eyewear complying with an approved standard should be used when a risk assessment indicates this is necessary to avoid exposure to liquid splashes, mists, gases or dusts. If inhalation hazards exist, a full-face respirator may be required instead.

Skin protection

- Hand protection** : Chemical-resistant gloves complying with an approved standard should be worn at all times when handling chemical products if a risk assessment indicates this is necessary.
- Body protection** : Personal protective equipment for the body should be selected based on the task being performed and the risks involved and should be approved by a specialist before handling this product.
- Other skin protection** : Appropriate footwear and any additional skin protection measures should be selected based on the task being performed and the risks involved and should be approved by a specialist before handling this product.
- Respiratory protection** : Use a properly fitted, air-purifying or supplied-air respirator complying with an approved standard if a risk assessment indicates this is necessary. Respirator selection must be based on known or anticipated exposure levels, the hazards of the product and the safe working limits of the selected respirator.

Section 9. Physical and chemical properties

- Physical state** : Liquid.
- Color** : Light amber [Light]
- Odor** : Mild petroleum odor [Slight]
- pH** : Not applicable.
- Boiling point** : Not available.
- Flash point** : Open cup: 230°C (446°F) [Cleveland.]
- Lower and upper explosive (flammable) limits** : Not available.
- Vapor pressure** : Not available.
- Vapor density** : Not available.
- Relative density** : Not available.
- Density lbs/gal** : 7.2 lbs/gal
- Gravity, °API** : 32.3
- Viscosity** : Dynamic (room temperature): Not applicable.
Kinematic (room temperature): Not applicable.
Kinematic (40°C (104°F)): 0.48 cm²/s (48 cSt)

Section 9. Physical and chemical properties

Viscosity SUS : 240 SUS @100 F

Section 10. Stability and reactivity

Reactivity : Not expected to be Explosive, Self-Reactive, Self-Heating, or an Organic Peroxide under US GHS Definition(s).

Chemical stability : The product is stable.

Possibility of hazardous reactions : Under normal conditions of storage and use, hazardous reactions will not occur.

Conditions to avoid : No specific data.

Incompatible materials : No specific data.

Hazardous decomposition products : Under normal conditions of storage and use, hazardous decomposition products should not be produced.

Section 11. Toxicological information

Information on toxicological effects

Acute toxicity

Conclusion/Summary : **Distillates (petroleum), hydrotreated heavy paraffinic**: Mineral oil mists derived from highly refined oils are reported to have low acute and sub-acute toxicities in animals. Effects from single and short-term repeated exposures to high concentrations of mineral oil mists well above applicable workplace exposure levels include lung inflammatory reaction, lipoid granuloma formation and lipoid pneumonia. In acute and sub-acute studies involving exposures to lower concentrations of mineral oil mists at or near current work place exposure levels produced no significant toxicological effects.

Irritation/Corrosion

Skin : No additional information.

Eyes : No additional information.

Respiratory : No additional information.

Sensitization

Skin : No additional information.

Respiratory : No additional information.

Mutagenicity

Conclusion/Summary : No additional information.

Carcinogenicity

Conclusion/Summary : No additional information.

Reproductive toxicity

Conclusion/Summary : No additional information.

Teratogenicity

Conclusion/Summary : No additional information.

Specific target organ toxicity (single exposure)

Not available.

Specific target organ toxicity (repeated exposure)

Not available.

Aspiration hazard

Not available.

Section 11. Toxicological information

Information on the likely routes of exposure : Not available.

Potential acute health effects

- Eye contact** : No known significant effects or critical hazards.
Inhalation : No known significant effects or critical hazards.
Skin contact : Injection of pressurized hydrocarbons can cause severe permanent tissue damage. Initial symptoms may be minor.
Ingestion : No known significant effects or critical hazards.

Symptoms related to the physical, chemical and toxicological characteristics

- Eye contact** : No specific data.
Inhalation : No specific data.
Skin contact : No specific data.
Ingestion : No specific data.

Potential chronic health effects

- General** : No known significant effects or critical hazards.
Carcinogenicity : No known significant effects or critical hazards.
Mutagenicity : No known significant effects or critical hazards.
Teratogenicity : No known significant effects or critical hazards.
Developmental effects : No known significant effects or critical hazards.
Fertility effects : No known significant effects or critical hazards.

Section 12. Ecological information

Toxicity

Conclusion/Summary : Not available.

Persistence and degradability

Conclusion/Summary : Not available.

Bioaccumulative potential

Not available.

Mobility in soil

Soil/water partition coefficient (K_{oc}) : Not available.

Other adverse effects : No known significant effects or critical hazards.

Section 13. Disposal considerations

Disposal methods : The generation of waste should be avoided or minimized wherever possible. Disposal of this product, solutions and any by-products should at all times comply with the requirements of environmental protection and waste disposal legislation and any regional local authority requirements. Dispose of surplus and non-recyclable products via a licensed waste disposal contractor. Waste should not be disposed of untreated to the sewer unless fully compliant with the requirements of all authorities with jurisdiction. Waste packaging should be recycled. This material and its container must be disposed

Section 13. Disposal considerations

of in a safe way. Empty containers or liners may retain some product residues. Avoid dispersal of spilled material and runoff and contact with soil, waterways, drains and sewers.

Section 14. Transport information

	DOT Classification	IMDG	IATA
UN number	Not regulated.	Not regulated.	Not regulated.
UN proper shipping name	-	-	-
Transport hazard class(es)	-	-	-
Packing group	-	-	-
Environmental hazards	No.	No.	No.
Additional information	-	-	-

Special precautions for user : **Transport within user's premises:** always transport in closed containers that are upright and secure. Ensure that persons transporting the product know what to do in the event of an accident or spillage.

Transport in bulk according to Annex II of MARPOL 73/78 and the IBC Code : Not available.

Section 15. Regulatory information

U.S. Federal regulations : **United States inventory (TSCA 8b):** All components are listed or exempted.
Clean Water Act (CWA) 307: Zinc and zinc compounds; toluene; phenol; lead; Cadmium (Non-pyrophoric); benzene
Clean Water Act (CWA) 311: toluene; phenol; benzene
 This material is classified as an oil under Section 311 of the Clean Water Act (CWA) and the Oil Pollution Act of 1990 (OPA). Discharges or spills which produce a visible sheen on waters of the United States, their adjoining shorelines, or into conduits leading to surface waters must be reported to the EPA's National Response Center at (800) 424-8802.

SARA 302/304

Composition/information on ingredients

SARA 304 RQ : Not applicable.

SARA 311/312

Classification : Not applicable.

Composition/information on ingredients

State regulations

Massachusetts : None of the components are listed.

New York : None of the components are listed.

Section 15. Regulatory information

New Jersey : None of the components are listed.

Pennsylvania : None of the components are listed.

California Prop. 65

WARNING: This product contains less than 0.1% of a chemical known to the State of California to cause cancer.

WARNING: This product contains less than 1% of a chemical known to the State of California to cause birth defects or other reproductive harm.

Ingredient name	%	Cancer	Reproductive	No significant risk level	Maximum acceptable dosage level
toluene	<0.01	No.	Yes.	No.	7000 µg/day (ingestion)
ethyl acrylate	<0.0001	Yes.	No.	No.	No.
lead	trace	Yes.	Yes.	15 µg/day (ingestion)	Yes.
Cadmium (Non-pyrophoric)	trace	Yes.	Yes.	0.05 µg/day (inhalation)	4.1 µg/day (ingestion)
benzene	trace	Yes.	Yes.	6.4 µg/day (ingestion) 13 µg/day (inhalation)	24 µg/day (ingestion) 49 µg/day (inhalation)

International regulations

International lists

Australia inventory (AICS): All components are listed or exempted.

China inventory (IECSC): All components are listed or exempted.

Japan inventory: All components are listed or exempted.

Korea inventory: All components are listed or exempted.

Malaysia Inventory (EHS Register): Not determined.

New Zealand Inventory of Chemicals (NZIoC): All components are listed or exempted.

Philippines inventory (PICCS): All components are listed or exempted.

Taiwan inventory (CSNN): Not determined.

Canada inventory : All components are listed or exempted.

EU Inventory : All components are listed or exempted.

WHMIS (Canada) : Not controlled under WHMIS (Canada).

Section 16. Other information

National Fire Protection Association (U.S.A.)



Reprinted with permission from NFPA 704-2001, Identification of the Hazards of Materials for Emergency Response Copyright ©1997, National Fire Protection Association, Quincy, MA 02269. This reprinted material is not the complete and official position of the National Fire Protection Association, on the referenced subject which is represented only by the standard in its entirety.

Copyright ©2001, National Fire Protection Association, Quincy, MA 02269. This warning system is intended to be interpreted and applied only by properly trained individuals to identify fire, health and reactivity hazards of chemicals. The user is referred to certain limited number of chemicals with recommended classifications in NFPA 49 and NFPA 325, which would be used as a guideline only. Whether the chemicals are classified by NFPA or not, anyone using the 704 systems to classify chemicals does so at their own risk.

History

Date of issue/Date of revision : 11/20/2014.

Section 16. Other information

Key to abbreviations

- : ATE = Acute Toxicity Estimate
- BCF = Bioconcentration Factor
- GHS = Globally Harmonized System of Classification and Labelling of Chemicals
- IATA = International Air Transport Association
- IBC = Intermediate Bulk Container
- IMDG = International Maritime Dangerous Goods
- LogPow = logarithm of the octanol/water partition coefficient
- MARPOL 73/78 = International Convention for the Prevention of Pollution From Ships, 1973 as modified by the Protocol of 1978. ("Marpol" = marine pollution)
- UN = United Nations

Notice to reader

THE INFORMATION IN THIS SAFETY DATA SHEET (SDS) WAS OBTAINED FROM SOURCES WHICH WE BELIEVE ARE RELIABLE. HOWEVER, THE INFORMATION IS PROVIDED WITHOUT ANY WARRANTY, EXPRESSED OR IMPLIED REGARDING ITS CORRECTNESS OR ACCURACY. SOME INFORMATION PRESENTED AND CONCLUSIONS DRAWN HEREIN ARE FROM SOURCES OTHER THAN DIRECT TEST DATA ON THE SUBSTANCE ITSELF. THIS SDS WAS PREPARED AND IS TO BE USED ONLY FOR THIS PRODUCT. IF THE PRODUCT IS USED AS A COMPONENT IN ANOTHER PRODUCT, THIS SDS INFORMATION MAY NOT BE APPLICABLE. USERS SHOULD MAKE THEIR OWN INVESTIGATIONS TO DETERMINE THE SUITABILITY OF THE INFORMATION OR PRODUCTS FOR THEIR PARTICULAR PURPOSE OR APPLICATION.

THE CONDITIONS OR METHODS OF HANDLING, STORAGE, USE, AND/OR DISPOSAL OF THE PRODUCT ARE BEYOND OUR CONTROL AND MAY BE BEYOND OUR KNOWLEDGE. FOR THIS AND OTHER REASONS, WE DO NOT ASSUME RESPONSIBILITY AND EXPRESSLY DISCLAIM LIABILITY FOR ANY LOSS, DAMAGE OR EXPENSE ARISING OUT OF OR IN ANY WAY CONNECTED WITH HANDLING, STORAGE, USE OR DISPOSAL OF THE PRODUCT.

CITGO is a registered trademark of CITGO Petroleum Corporation



MATERIAL SAFETY DATA SHEET

Print date: 25-Oct-2010

Revision Number: 1

Revision date: 19-Oct-2010

1. IDENTIFICATION OF THE SUBSTANCE/PREPARATION AND THE COMPANY/UNDERTAKING

Product Name: Klübersynth GH 6- 460
Article Code: 012163
Synonyms: No information available
Chemical characterisation: Not applicable..

Supplier:
Klüber Lubrication North America L.P.
32 Industrial Drive
Londonderry, NH 03053
(603) 647-4104
Fax (603) 647-4106

Emergency telephone number CHEMTREC: 1-800-424-9300 International: (703) 527-3887

2. COMPOSITION/INFORMATION ON INGREDIENTS

Components	CAS-No	ACGIH (TWA mg/m ³):	OSHA (TWA mg/m ³):
Polyalkylene glycol oil		None	None

3. HAZARDS IDENTIFICATION

Properties affecting health: Harmful if swallowed

Principle routes of exposure: Skin.

Skin contact: Substance may cause slight skin irritation.

Eye contact: Contact with eyes may cause irritation.

Inhalation: Vapors and/or aerosols which may be formed at elevated temperatures may be irritating to eyes and respiratory tract.

Ingestion: Harmful if swallowed. Ingestion may cause gastrointestinal irritation, nausea, vomiting and diarrhoea

4. FIRST AID MEASURES

General advice: If symptoms persist, call a physician.

Skin contact: Rinse with plenty of water. If skin irritation persists, call a physician.

Inhalation: Move to fresh air in case of accidental inhalation of fumes from overheating or combustion. If symptoms persist, call a physician.

Eye contact: Flush eye with water for 15 minutes. If symptoms persist, call a physician.

Ingestion: Do not induce vomiting. Consult a physician.

Notes to physician: Treat symptomatically.

5. FIRE-FIGHTING MEASURES

Suitable extinguishing media:

Carbon dioxide (CO₂), Dry chemical, Dry sand, Water spray mist or foam

Extinguishing media which must not be used for safety reasons:

Do not use a solid water stream as it may scatter and spread fire.

Special protective equipment for firefighters:

In the event of fire and/or explosion do not breathe fumes. In the event of fire, wear self-contained breathing apparatus. Standard procedure for chemical fires.

Specific hazards: Burning produces irritant fumes In the event of fire and/or explosion do not breathe fumes

Unusual hazards: No hazards resulting from the material as supplied

Specific methods: Water mist may be used to cool closed containers. Standard procedure for chemical fires.

Flash point: > 482 (°F)

Autoignition temperature: Not determined..

Flammability Limits in Air:

Lower No information available

Upper No information available

6. ACCIDENTAL RELEASE MEASURES

Personal precautions: Contaminated surfaces will be extremely slippery. Avoid contact with skin, eyes and clothing. Wear personal protective equipment.

Environmental precautions: Prevent further leakage or spillage if safe to do so. Do not allow material to contaminate ground water system. Prevent product from entering drains.

Methods for cleaning up: Soak up with oil absorbent material. Clean contaminated surface thoroughly. Pick up and transfer to properly labelled containers.

7. HANDLING AND STORAGE

Handling

Technical measures/precautions:

Safe handling advice:

No special technical protective measures required.

Spilling onto the container's outside will make container slippery. Avoid contact with skin, eyes and clothing. Handle in accordance with good industrial hygiene and safety practice.

Storage

Technical measures/storage conditions:

Keep containers tightly closed in a dry, cool and well-ventilated place. Keep away from open flames, hot surfaces and sources of ignition. Keep in properly labelled containers. Keep out of reach of children.

Incompatible products:

Oxidising and spontaneously flammable products.

8. EXPOSURE CONTROLS / PERSONAL PROTECTION

Engineering measures to reduce exposure:

Ensure adequate ventilation, especially in confined areas..

Personal Protective Equipment

Respiratory protection:	No personal respiratory protective equipment normally required.
Hand protection:	Preventive skin protection
Skin and body protection:	Usual safety precautions while handling the product will provide adequate protection against this potential effect..
Eye protection:	Avoid contact with eyes..
Hygiene measures:	Avoid contact with skin, eyes and clothing.

9. PHYSICAL AND CHEMICAL PROPERTIES

Physical State:	Oil	Appearance:	Liquid
Color:	Light yellow	Odor:	Not significant
Specific gravity:	~ 1.07	Boiling point/range	No information available
Evaporation rate:	Not determined	Vapor density:	Not determined
Vapor pressure:	Not determined	Solubility:	Partly soluble.

10. STABILITY AND REACTIVITY

Stability:	No hazards to be especially mentioned
Polymerization:	Hazardous polymerisation does not occur.
Hazardous decomposition products:	None under normal use
Materials to avoid:	Strong oxidising agents.
Conditions to avoid:	Heat, flames and sparks..

11. TOXICOLOGICAL INFORMATION

Acute toxicity:	No data available
------------------------	-------------------

12. ECOLOGICAL INFORMATION

Mobility:	No information available.
Bioaccumulative potential:	No information available.
Ecotoxicity effects:	May cause long-term adverse effects in the aquatic environment..
Aquatic toxicity:	May cause long-term adverse effects in the aquatic environment.

13. DISPOSAL CONSIDERATIONS

Waste from residues / unused products:	In accordance with local and national regulations.
Contaminated packaging:	Empty containers should be taken for local recycling, recovery or waste disposal

14. TRANSPORT INFORMATION

DOT

Proper shipping name:	Bulk Packaging: Environmentally hazardous substances, liquid, n.o.s. (Cresyl diphenyl phosphate and Triphenylphosphate)
UN-No:	UN3082
Hazard Class:	9
Packing group:	III
ERG No:	171

14. TRANSPORT INFORMATION

TDG (Canada)

IMO / IMDG

ICAO

IATA

15. REGULATORY INFORMATION

TSCA

TSCA: Listed in TSCA

U.S. Regulations:

Sara (311, 312) hazard class:

Canada

WHMIS hazard class:
Non-controlled

16. OTHER INFORMATION

<u>NFPA</u>	Health: 1	Flammability: 1	Instability: 0
<u>HMIS</u>	Health: 1	Flammability: 1	Physical Hazard: 0

Reason for revision: Not applicable
Prepared by: Health & Safety

The information and recommendations contained herein are based upon tests believed to be reliable. However, Klüber does not guarantee their accuracy or completeness NOR SHALL ANY OF THIS INFORMATION CONSTITUTE A WARRANTY, WHETHER EXPRESSED OR IMPLIED, AS TO THE SAFETY OF THE GOODS, THE MERCHANTABILITY OF THE GOODS, OR THE FITNESS OF THE GOODS FOR A PARTICULAR PURPOSE. Adjustment to conform to actual conditions of usage maybe required. Klüber assumes no responsibility for results obtained or for incidental or consequential damages, including lost profits arising from the use of these data. No warranty against infringement of any patent, copyright or trademark is made or implied.

Section 1
SAFETY

SECTION 1
SAFETY

State Regulations

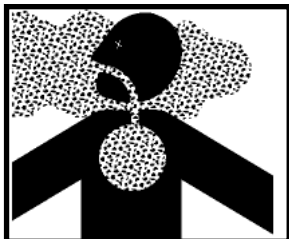

WARNING

SILICOSIS WARNING

Grinding/cutting/drilling of masonry, concrete, metal and other materials with silica in their composition may give off dust or mists containing crystalline silica. Silica is a basic component of sand, quartz, brick clay, granite and numerous other minerals and rocks. Repeated and/or substantial inhalation of airborne crystalline silica can cause serious or fatal respiratory diseases, including silicosis. In addition, California and some other authorities have listed respirable crystalline silica as a substance known to cause cancer. When cutting such materials, always follow the respiratory precautions mentioned above.

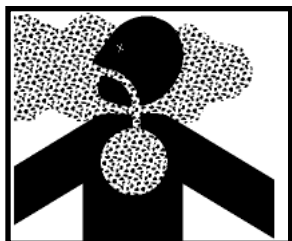

WARNING

RESPIRATORY HAZARDS

Grinding/cutting/drilling of masonry, concrete, metal and other materials can generate dust, mists and fumes containing chemicals known to cause serious or fatal injury or illness, such as respiratory disease, cancer, birth defects or other reproductive harm. If you are unfamiliar with the risks associated with the particular process and/or material being cut or the composition of the tool being used, review the material safety data sheet and/or consult your employer, the material manufacturer/supplier, governmental agencies such as OSHA and NIOSH and other sources on hazardous materials. California and some other authorities, for instance, have published lists of substances known to cause cancer, reproductive toxicity, or other harmful effects.

Control dust, mist and fumes at the source where possible. In this regard use good work practices and follow the recommendations of the manufacturers or suppliers, OSHA/NIOSH, and occupational and trade associations. Water should be used for dust suppression when wet cutting is feasible. When the hazards from inhalation of dust, mists and fumes cannot be eliminated, the operator and any bystanders should always wear a respirator approved by NIOSH/MSHA for the materials being used.

SECTION 1 SAFETY

1.1 General Safety Precautions

1.1.1 Safety-Alert Signs

This manual contains Safety-Alert Signs, as defined below, which must be followed to reduce the possibility of improper service damage to the equipment or personal injury. Read and follow all Safety-Alert Signs included in this manual.



NOTE defines an operating procedure, condition, etc. which is essential to highlight that contains useful or important information.

EMERGENCY

EMERGENCY is used for the identification of safety equipment, first aid, or emergency egress locations.

NOTICE

NOTICE used to convey safety information on labels and signs.



CAUTION is indicative of a potentially hazardous situation which, if not avoided, may result in minor or moderate injury.



Potentially hazardous situations that could result in death or serious injury are indicated by the word WARNING.



DANGER indicates an imminently hazardous situation which, if not avoided, will result in death or serious injury.

1.2 Operating Safety

SECTION 1 SAFETY

1.3.1 Operating Safety



Familiarity and proper training are required for the safe operation of this equipment! Equipment operated improperly or by untrained personnel can be dangerous! Read the operating instructions contained in both this manual and the engine manual and familiarize yourself with the location and proper use of all controls.

- 1.3.2 **NEVER** operate this machine in applications for which it is not intended.
- 1.3.3 **NEVER** allow anyone to operate this equipment without proper training. People operating this equipment must be familiar with the risks and hazards associated with it.
- 1.3.4 **NEVER** touch the engine or muffler while the engine is on or immediately after it has been turned off. These areas get hot and may cause burns.
- 1.3.5 **NEVER** use accessories or attachments that are not recommended by AEC. Damage to equipment and injury to the user may result.
- 1.3.6 **NEVER**
- 1.3.7 **NEVER** leave machine running unattended.
- 1.3.8 **DO NOT** run the machine indoors or in an enclosed area such as a deep trench unless adequate ventilation, through such items as exhaust fans or hoses, is provided. Exhaust gas from the engine contains poisonous carbon monoxide gas; exposure to carbon monoxide can cause loss of consciousness and may lead to death.
- 1.3.9 **ALWAYS** remain aware of moving parts and keep hands, feet, and loose clothing away from the moving parts of the equipment.
- 1.3.10 **ALWAYS** keep hands, feet, and loose clothing away from moving parts of the machine.
- 1.3.11 **ALWAYS** read, understand, and follow procedures in the Operator's Manual before attempting to operate the equipment.
- 1.3.12 **ALWAYS** be sure operator is familiar with proper safety precautions and operation techniques before using machine.

SECTION 1
SAFETY

1.2, continued
Operating Safety

- 1.3.13 **ALWAYS** close fuel valve on engines equipped with one when machine is not being operated.
- 1.3.14 **ALWAYS** store the equipment properly when it is not being used. Equipment should be stored in a clean, dry location out of the reach of children.

ALLEN
CONCRETE PAVERS

1.3 Engine Safety

SECTION 1 SAFETY

1.4.1 Engine Safety



Internal combustion engines present special hazards during operation and fueling. Read and follow the warning instructions in the engine owner's manual and the safety guidelines below. Failure to follow the warnings and safety guidelines could result in severe injury or death.

- 1.4.2 **DO NOT** run the machine indoors or in an enclosed area such as a deep trench unless adequate ventilation, through such items as exhaust fans or hoses, is provided. Exhaust gas from the engine contains poisonous carbon monoxide gas; exposure to carbon monoxide can cause loss of consciousness and may lead to death.
- 1.4.3 **DO NOT** smoke while operating the machine.
- 1.4.4 **DO NOT** smoke when refueling the engine.
- 1.4.5 **DO NOT** refuel a hot or running engine.
- 1.4.6 **DO NOT** refuel the engine near an open flame.
- 1.4.7 **DO NOT** spill fuel when refueling the engine.
- 1.4.8 **DO NOT** run the engine near open flames.
- 1.4.9 **ALWAYS** refill the fuel tank in a well-ventilated area.
- 1.4.10 **ALWAYS** replace the fuel tank cap after refueling.
- 1.4.11 **ALWAYS** keep the area around the muffler free of debris such as leaves, paper, cartons, etc. A hot muffler could ignite the debris and start a fire.

SECTION 1 SAFETY

1.4 Service Safety

1.5.1 Service Safety



Poorly maintained equipment can become a safety hazard! In order for the equipment to operate safely and properly over a long period of time, periodic maintenance and occasional repairs are necessary.

- 1.5.2 **DO NOT** attempt to clean or service the machine while it is running. Rotating parts can cause severe injury.
- 1.5.3 **DO NOT**
- 1.5.4 **DO NOT**
- 1.5.6 **DO NOT** use gasoline or other types of fuels or flammable solvents to clean parts, especially in enclosed areas. Fumes from fuels and solvents can become explosive.
- 1.5.7 **ALWAYS** turn engine off and remove key from machine before performing maintenance or making repairs.
- 1.5.8 **ALWAYS**
- 1.5.9 **ALWAYS** keep the area around the muffler free of debris such as leaves, paper, cartons, etc. A hot muffler could ignite the debris and start a fire.
- 1.5.10 **ALWAYS** replace worn or damaged components with spare parts designed and recommended by AEC Corporation.
- 1.5.11 **ALWAYS**
- 1.5.12 **ALWAYS** switch off the power supply at the battery disconnect before adjusting or maintaining the electrical equipment.
- 1.5.13 **ALWAYS** keep the machine clean and labels legible. Replace all missing and hard-to-read labels. Labels provide important operating instructions and warn of dangers and hazards.

1.5 Safety and Operation Labels

SECTION 1 SAFETY

The safety and operation labels shown in this section are placed in important areas on the machine to draw attention to potential safety hazards and service information. Should any of these labels become unreadable or damaged, replacement labels can be ordered from your distributor.

NOTE

This label identifies the tank used for retardant spray agents (i.e., water-based retardants) only on the machine. **NO OTHER** non-retardant chemicals nor fuel is to be in this tank.

**RETARDANT
ONLY**

CAUTION

For diesel-fueled machines, this label identifies the tank used for **DIESEL** fuel only in the machine. **NO OTHER** type of fuel is to be used in this tank.

**DIESEL
FUEL
ONLY**

CAUTION

This label identifies the tank used for **HYDRAULIC OIL** only in the machine. **NO OTHER** type of fluid is to be used in this tank.

**HYD. OIL
ONLY**

NOTE

This label identifies the valve that operates the finish tube only.

**FORWARD
FINISH TUBE
REVERSE**

**SECTION 1
SAFETY**

**1.5, continued
Safety and Operation Labels**

NOTE

This label identifies the valve that operates the travel tubes only.

**FORWARD
TRAVEL TUBE
REVERSE**

NOTE

This label identifies the valve that operates the steering leg only.

**UP
STEERING LEG
DOWN**

NOTE

This label identifies the adjustment nut location that raises and lowers the front finish tube.

**FINISH TUBE
VERTICAL
ADJUSTER**

WARNING

This label warns the operator of the potential hazard of severe burns from hot coolant if radiator is still hot and the radiator cap is removed before the coolant has had sufficient time to cool down.

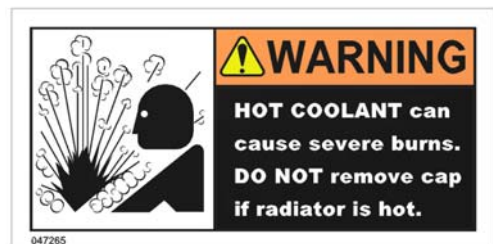

NOTE

This label identifies the location of the fuse box that contains the associated fuses that make up the internal electrical circuit of various components in the wiring system.

**FUSE BOX
INSIDE**

SECTION 1

SAFETY

INTENTIONALLY LEFT BLANK

Section 2
OPERATIONS

SECTION 2

OPERATIONS



This machine is built with user safety in mind. However, it can present hazards if improperly operated and serviced. Follow operating instructions carefully.

If you have any questions about operating or servicing this equipment, please contact your Allen Engineering Dealer or AEC Customer Service at 800-643-0095 or 870-236-7751.

2.1.1 Description

The **Triple Roller Tube Paver** (TRTP) is a simple, but effective, paving machine. This particular model is the largest of the TRTP family. The model 255CD paver is the paver of choice due to the fact of its optional accessories such as front and rear walkways as well as a gang vibration system for concrete consolidation. This machine also comes with a spray system which is a standard option.

Your machine is built from heavy duty steel for reliability and strength. The end frames and overhead truss-work are strongly built for the longer machines as well as the smaller ones. A weight box on the idle-end frame helps to balance out the machine due to the weight on the motor end frame.

This machine is built for the ultimate quick finish for a reasonable investment. The roller tubes on this machine are made of rugged 10" (254mm) diameter tubing. We can customize the length of your machine from 12 ft (3.05m) thru 34 ft. (10.97m) in any 2 ft (.61m) increment. No matter what conditions your job may be under, Allen Concrete Pavers (ACP) can make the machine to fit your needs.

Your machine primarily runs on a 44 HP, 4 cylinder, liquid cooled diesel engine. The liquid cooled engine is electrically started. All hydraulic components function mainly from the 14+3.2 GPM heavy-duty tandem pump mounted to the engine. The hydraulic and fuel tanks are constructed of a heavy-duty steel for durability.

The front paving tube has a variable speed control with forward and reverse movement. The maximum setting for the finishing tube is 146 RPM's and the maximum setting for the travel tube is 20 RPM's. However, this machine can finish an astounding 382 surface feet per minute.

2.2.1 Before Starting Procedures

Before starting the machine check for the following:

- 1) Oil level in engine(s).
- 2) Hydraulic oil level in hydraulic tank.
- 3) Fuel level in fuel tank.
- 4) Condition of hydraulic oil and air filters.
- 5) Verify that daily maintenance has been performed.
- 6) Verify all controls are in the neutral position.

2.2.2 Starting Procedures

Before starting the machine, refer to Figure 2.2.1 and 2.3.1 for location and identification of operational and visual controls pertaining to the operation of the TRTP.

- 1) Turn key counter-clockwise until the "GLOW PLUG" turns off.
- 2) Turn ignition switch key to the start-position, immediately release key when engine starts. Allow engine and hydraulic components to warm up for 5 minutes before operating machine.



Operating the starter for more than 5 seconds can damage the starter or engine. If engine fails to start release the switch and wait 15 seconds before operating starter again.

2.2, continued Start Up Procedures

SECTION 2 OPERATIONS

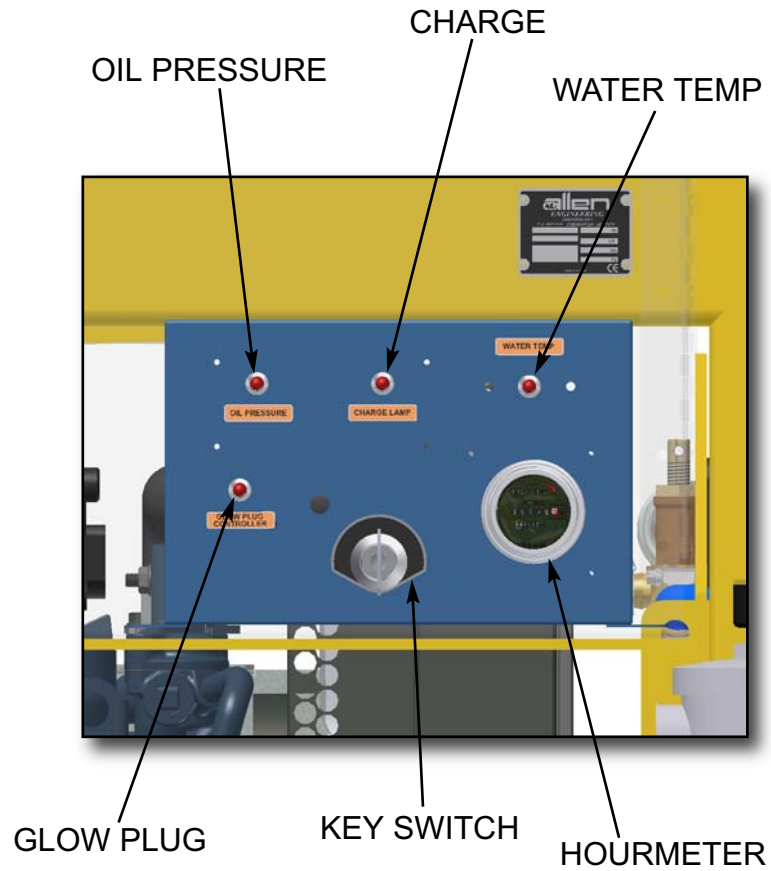

FIGURE 2.2.1
VIEW OF CONTROL BOX

SECTION 2 OPERATIONS

2.3 Operating Instructions

2.3.1 Operating the TRTP

1) Location of Operating Controls

- [A] Finish Tube Control
- [B] Steering Leg Control
- [C] Travel Tube Control
- [D] Front Tube Adjustment
- [E] Hydraulic Filter Gauge
- [F] Engine Control Box
- [G] Water Pump Control
- [H] Throttle Control

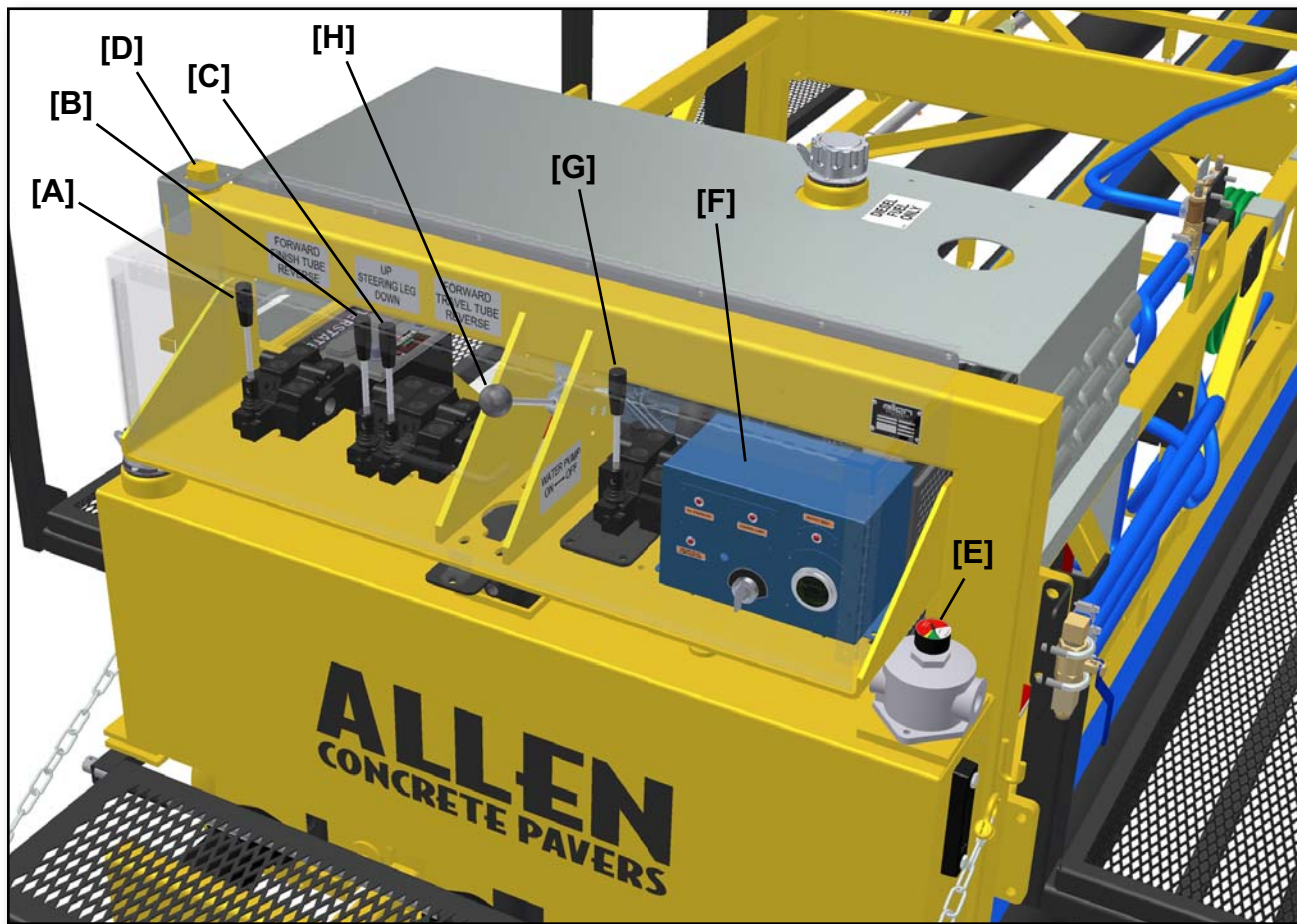

FIGURE 2.3.1
Operations Control Components

2.3, continued Operating Instructions

SECTION 2 OPERATIONS

- 2) The operation of this machine is easy to learn and is simple on the job. Without a whole lot of components and parts, with the exception of hoses and hydraulic components, this machine is a basic concrete paver. However, without proper instruction on how to operate this machine, it can very easily become hazardous to the surrounding workers, as well as, being unable to finish a good pour.
- After you start the engine, increase the throttle to 80% of the maximum engine RPM.
 - To start paving in the forward motion, push both of the operator levers up.
 - For paving in the reverse mode, pull the levers down.
 - To make all the tubes travel in the same direction (whether forward or reverse), push one lever up and pull the other down.
 - To turn the machine pull the steering leg lever all the way down. Once you have turned the desired distance, push the lever back up to lift up the leg.



DO NOT use excessive pressure on the controls.
Excessive pressure does not increase the reaction time of the machine and can damage controls.

2.3.2 Stopping The Machine

Return all the tube control levers to the neutral position.

2.3.3 Finish Tube Height Adjustment

To raise or lower the front finish tube do the following:

- Remove the tube adjustment lock(A) from the end handle.
- To raise the tube, turn the adjustment nut(B) in a clockwise rotation.
- To lower the tube, turn the adjustment counter-clockwise.

NOTE: The factory sets this tube at 1/8" above grade. There is a scribe line on the motor and idle end handles at the point where the tube is set. See Fig 2.3.4

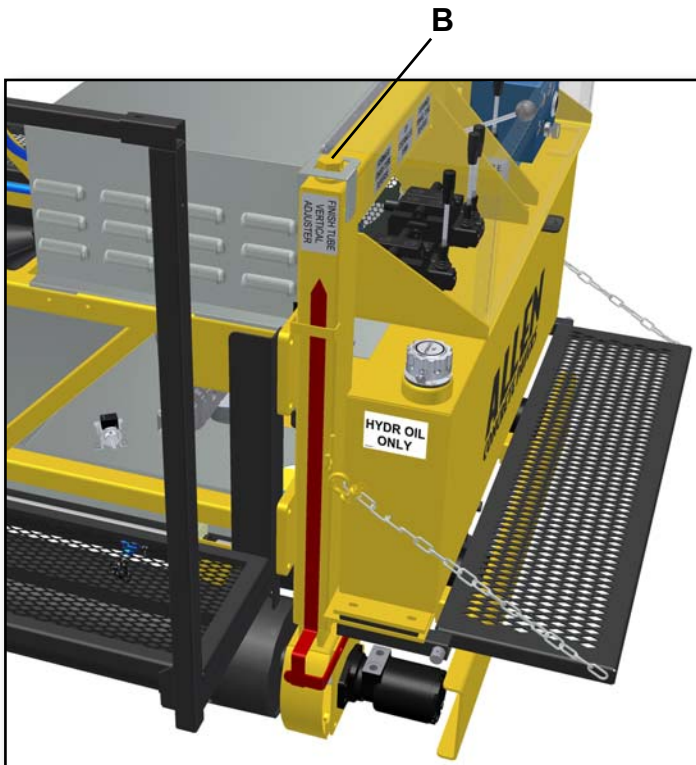

FIGURE 2.3.3
Front Tube Adjustment

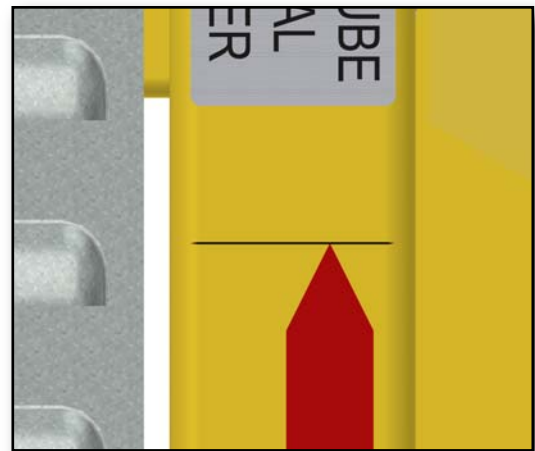
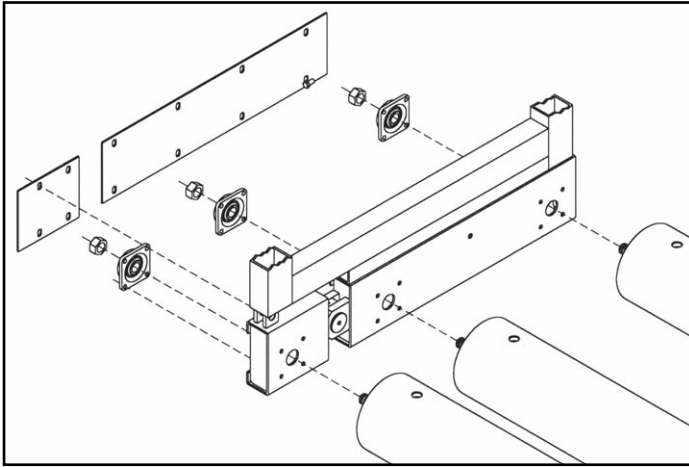

FIGURE 2.3.4
Pointer Scribe

2.3, continued Operating Instructions

SECTION 2 OPERATIONS

2.3.4 Tube Changing Procedures



Step 1: Remove the cover off of the idle end frame.

Step 2: Take the 1" nuts off of the idle end tubes.

Step 3: Loosen set screws on bearings.

Step 4: Take the 16 bolts off the idle end frame that connect the framework to the end frame.

NOTE: Make sure that the framework is supported by a crane to insure that the framework does not collapse.

Step 5: Remove the idle end frame.

Step 6: Using the same method as in step 4, take the framework apart or add to section by section until the desired length is achieved.

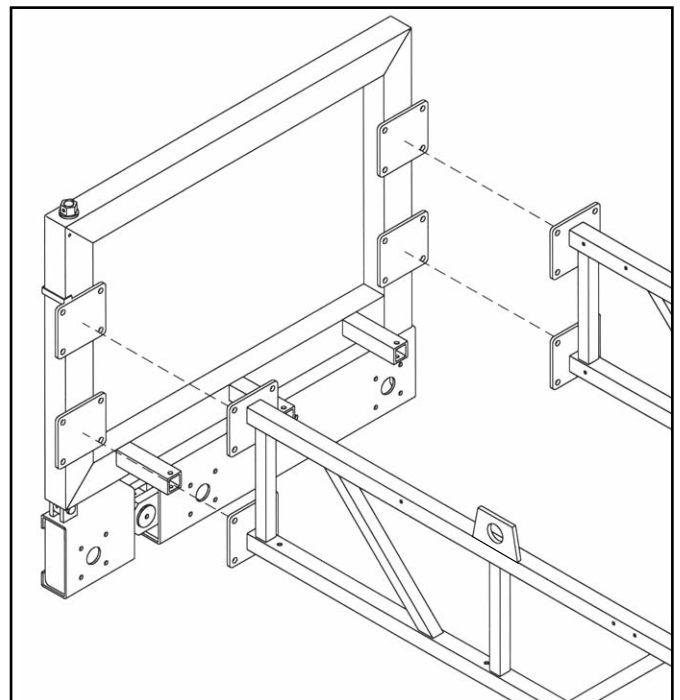

Step 7: Remove the 1/4" bolts from the hex drivers.

Step 8: Pull the tube out of the motor end frame, repeat this process with all three tubes.

Step 9: Replace with the new length tubes.

Step 10: Replace 1/4" bolts into the hex drivers.

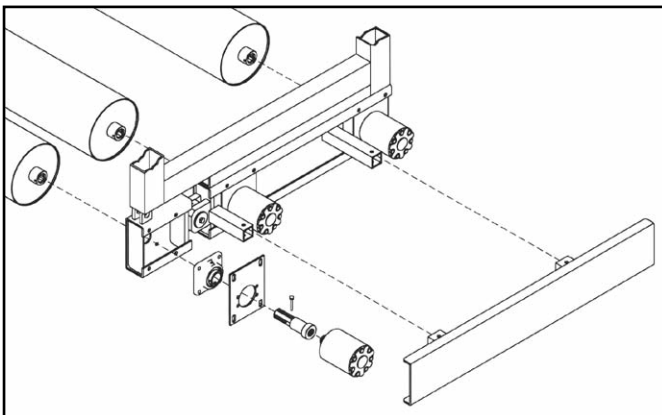

Starting with Step 6, reverse the process using the appropriate framework required. As the tube length changes, the framework obviously will change also.

Section 3
SERVICE

SECTION 3 SERVICE

3.1 Periodic Maintenance

3.1 Periodic Maintenance Schedule

The table below lists basic machine and engine maintenance. Refer to OEM engine manufacturer's Operation Manual for additional information on engine maintenance. A copy of the engine operator's manual was supplied with the machine when it was shipped.

TABLE 3.1.1
CHECK LIST

ITEM	DAILY	EVERY 20 HRS	EVERY 50 HRS	EVERY 100 HRS	EVERY 300 HRS
Hydraulic Oil Level	✓				
Fuel Level	✓				
Hoses and Fittings	✓				
External Hardware	✓				
Change Engine Oil				✓	
Grease Bearings		✓			
Replace Fuel Filter					✓
Replace Oil Filter				✓	
Check Valve Clearance			✓		
Air Filter	✓				
Hydraulic Motors			✓		
Steering Leg			✓		
Hydraulic Filters	✓				

3.2 Roller Tube Bearings

SECTION 3 SERVICE

3.2 Bearings

The bearings for the roller tubes must be greased approximately every 20 hours. Please note the location of the grease fittings below.

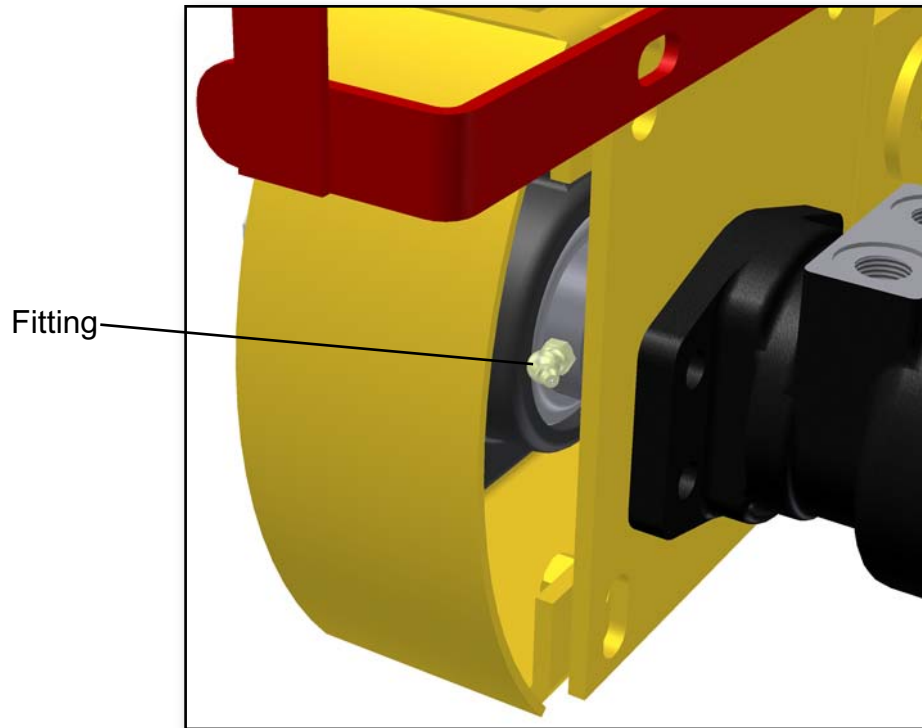

FIGURE 3.2.1
MOTOR END FITTINGS

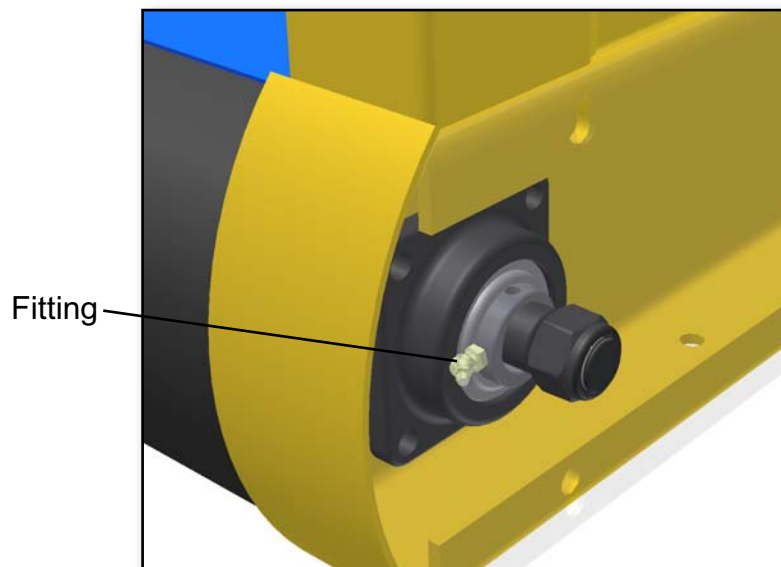
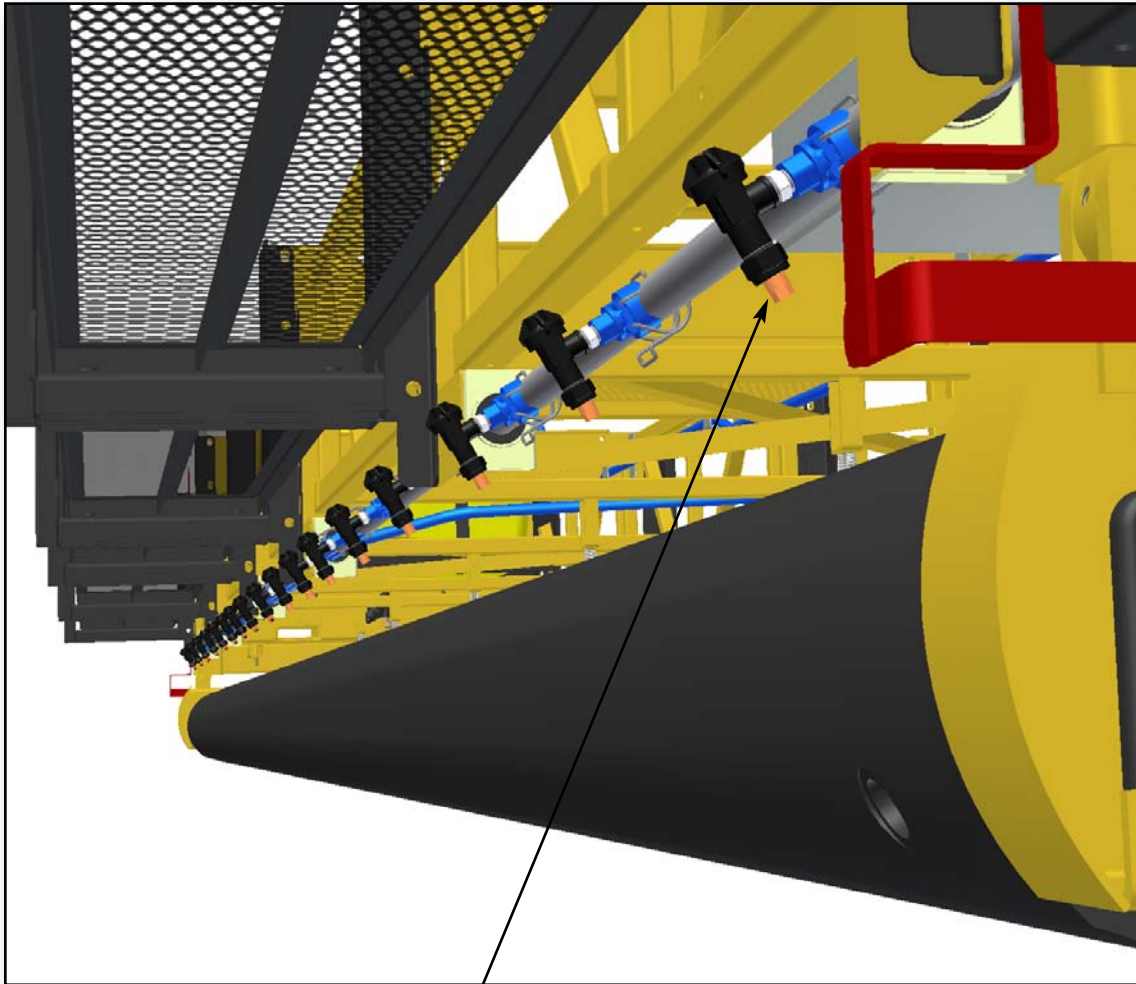

FIGURE 3.2.2
IDLE END FITTINGS

3.3
Spray Tips

3.3 Spray Tips

Make sure before every pour that all the finish tube spray tips and nozzles are not clogged and are in working order. Also make sure that they are drip free when the spray system is not on.



Spray Tips

FIGURE 3.3.1
SPRAY TIPS

3.4 Inline Spray Filter

SECTION 3 SERVICE

3.4 Inline Spray Filter

Make sure before every pour and before the filling the tank that the inline spray filter is free of contaminants. If the filter needs to be replaced, an AEC filter replacement is available.

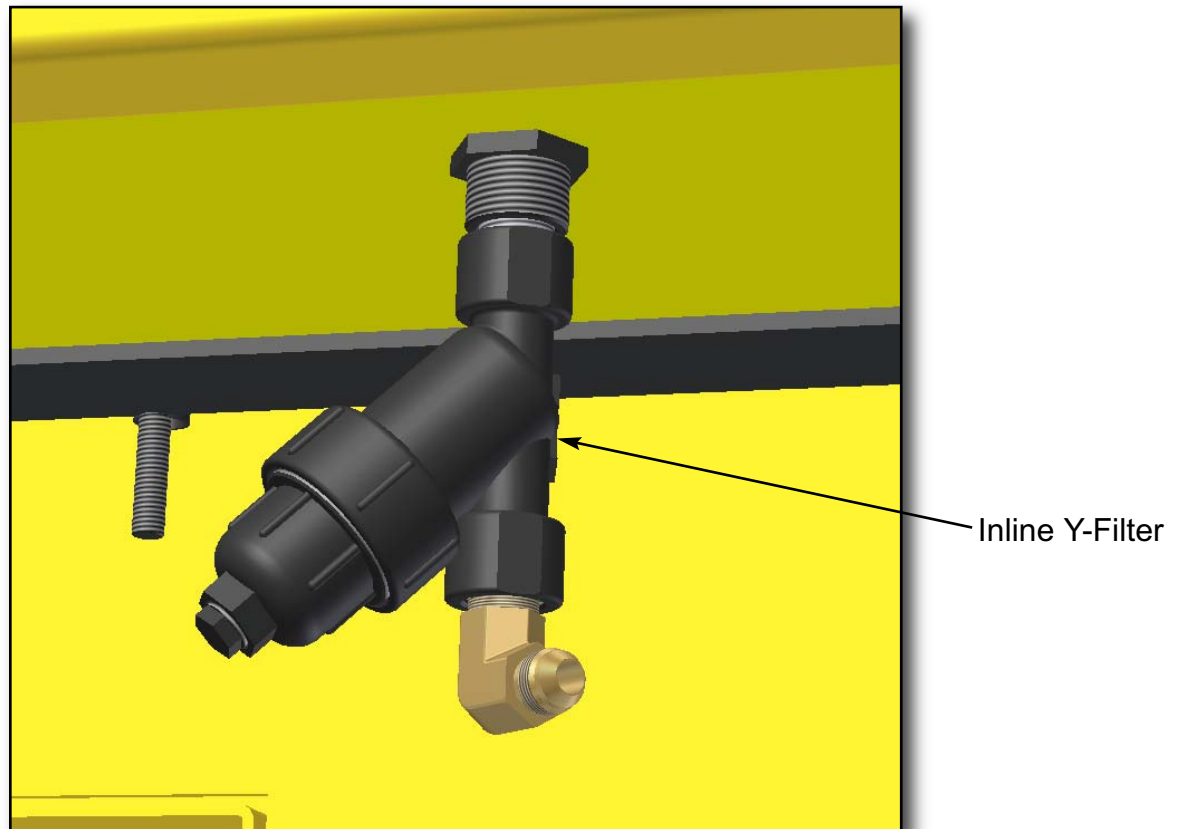
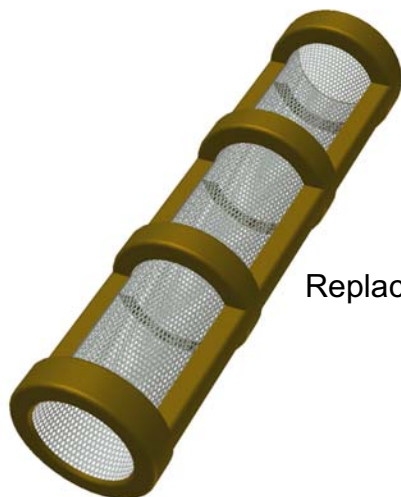

FIGURE 3.4.1
INLINE SPRAY FILTER



Replacement Filter: **048383**

SECTION 3 SERVICE

3.5 Air Filter - Breather

3.5 Air Breather

Make sure that the air breather is free of contaminants before each pour. This ensures the turbo will function at its peak efficiency.

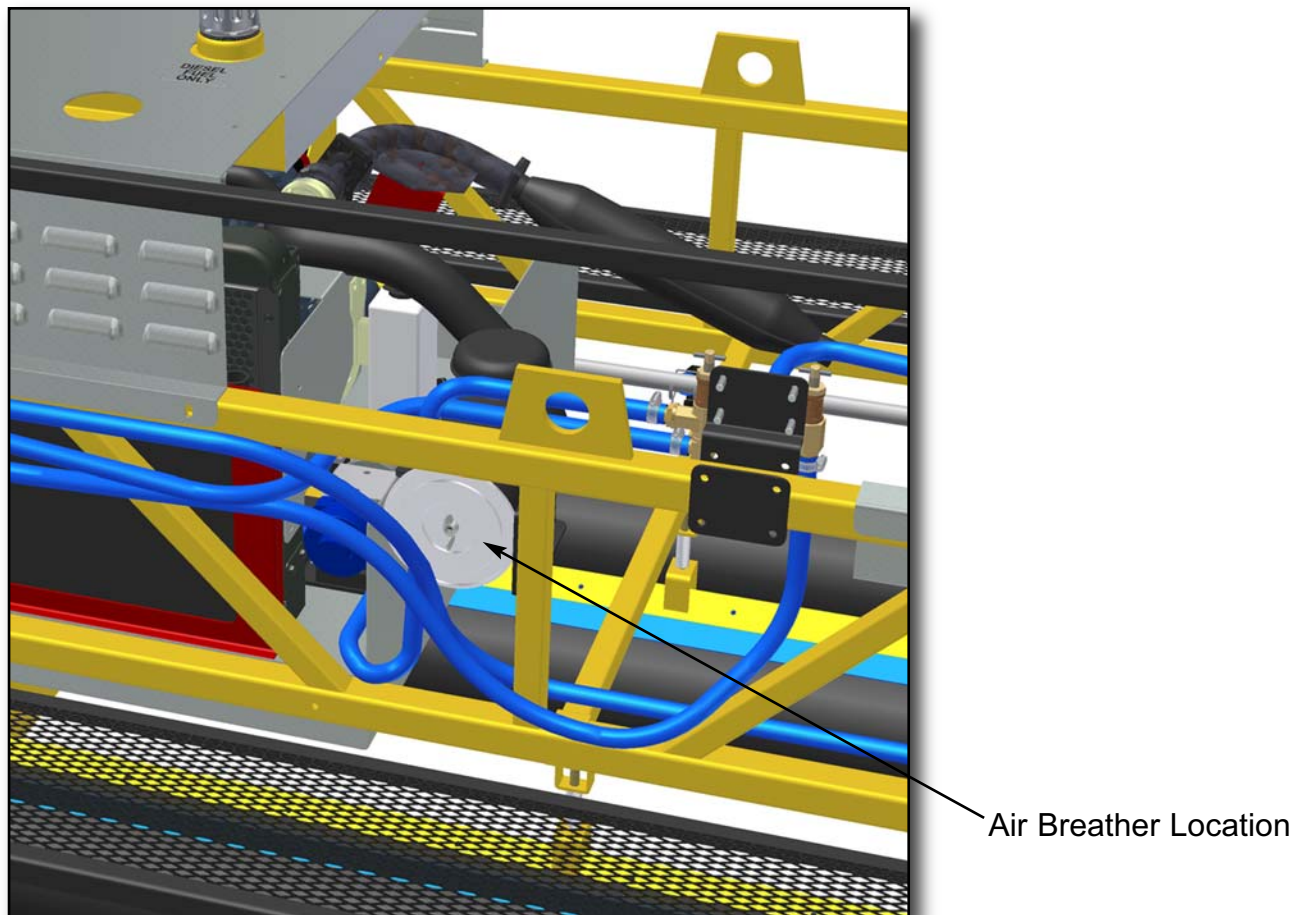
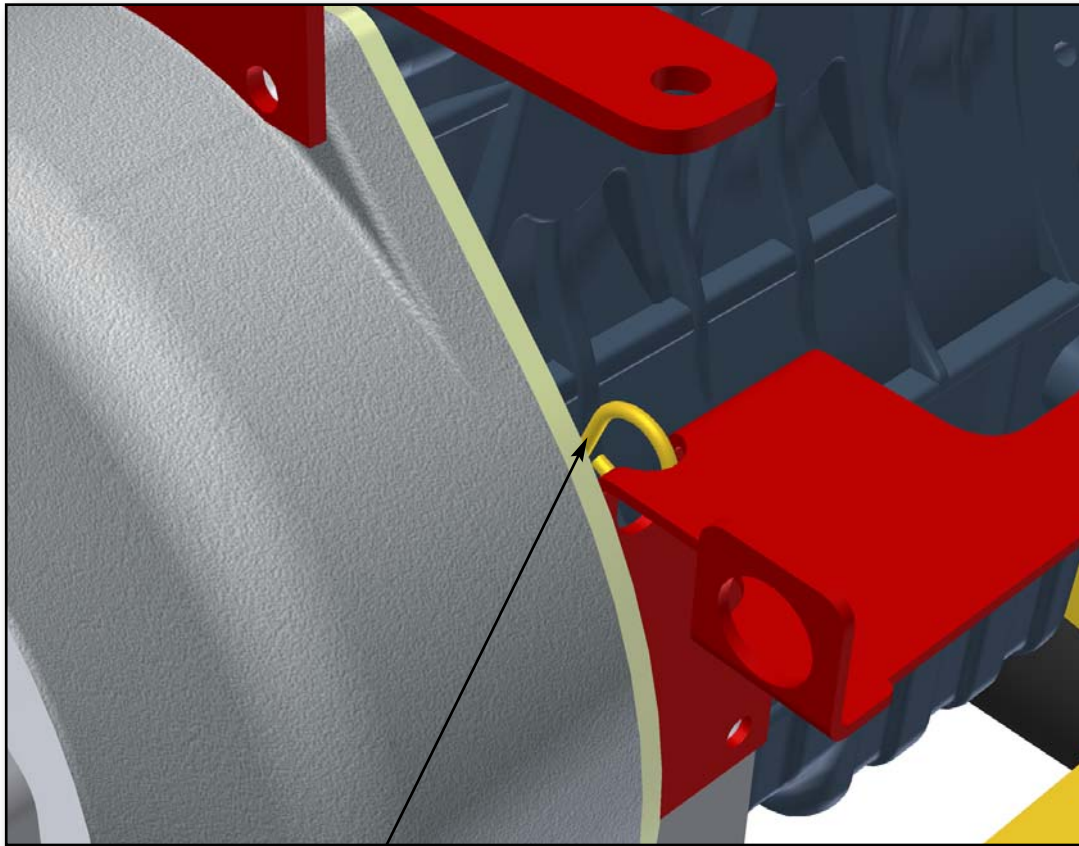

FIGURE 3.5.1
AIR FILTER

3.6 Engine Oil

Check engine oil daily.



Dipstick Location

FIGURE 3.6.1
Engine Oil

SECTION 3 SERVICE

3.7 Oil and Fuel Filters

3.7 Oil Filter

Replace oil filter approximately every 100 operating hours.

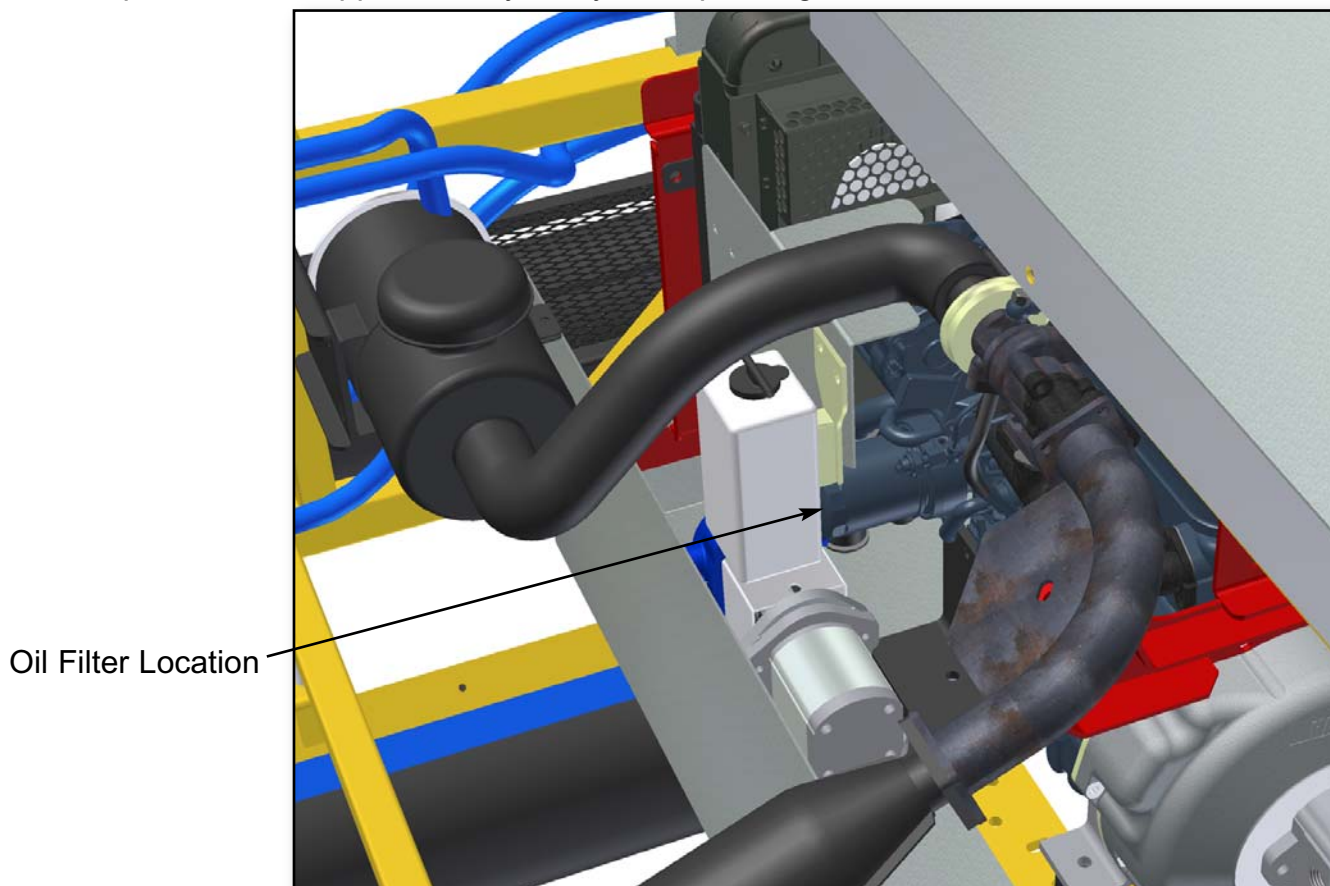

FIGURE 3.7.1
Oil Filter

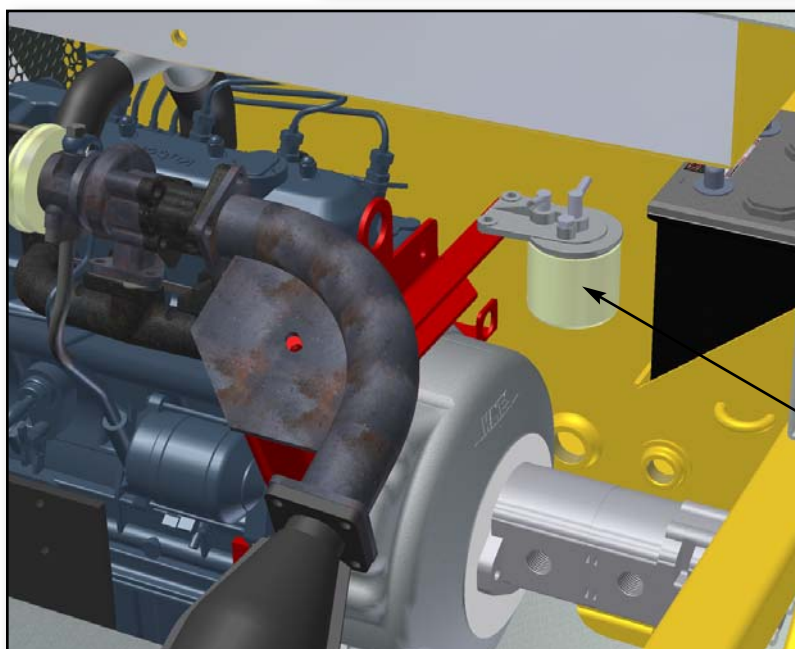

FIGURE 3.7.2
Fuel Filter

***Section 4
PARTS***

SECTION 4 PARTS

Factory Service Information

This section contains the illustrated drawings and parts list for help in identifying and/or ordering replacement parts for your machine. Follow the instructions in the front section of this manual “Ordering Parts” when ordering replacement parts to insure prompt and accurate delivery.

NOTE

All set screws have blue (LOC-TITE™) applied at the factory. If set screw is removed or loosened for any reason re-apply blue (LOC-TITE™).

NOTE

All grease fittings are capped with CAP PLUG GC-5 (AEC PN 015692) to protect the fitting. If cap becomes missing or damaged replace it as soon as possible.

NOTE

Anti-Seize is applied at the factory to all tube couplings. If these parts are disassembled re-apply a light coat of a graphite based anti-seize.

We recommend AEC quality replacement parts, available from the AEC Customer Service Department or your nearest AEC Dealer.

Part numbers are subject to change without notice. Part numbers might be different outside of the United States of America. Use part numbers listed in the applicable parts list table when you place your order. If a part number changes, the AEC Customer Service Department or your nearest AEC dealer will have the latest part number for the replacement part.

Remember when you order replacement parts, you will need your model number and serial number. These are the numbers that you have recorded in the UNIT ID section of this manual. Please order replacement parts by the appropriate part number, not the key number.

This manual contains an illustrated parts list for help in ordering replacement parts for your machine. Follow the instructions below when ordering parts to insure prompt and accurate delivery:

1. All orders for service parts - include the serial number for the machine. Shipment will be delayed if this information is not available.
2. Include correct description and part number from the "PARTS" Section 4.
3. Specify exact shipping instructions, including the preferred routing and complete destination address.
4. **DO NOT** return parts to AEC without receiving written authorization from AEC. All authorized returns must be shipped pre-paid.
5. When placing an order, please contact the AEC Dealer nearest you.

NOTE

All information, specifications, and illustrations in this manual are subject to change without notice and are based on the latest information at the time of publication.

SECTION 4 PARTS

4.1 Illustration Power Unit Assembly

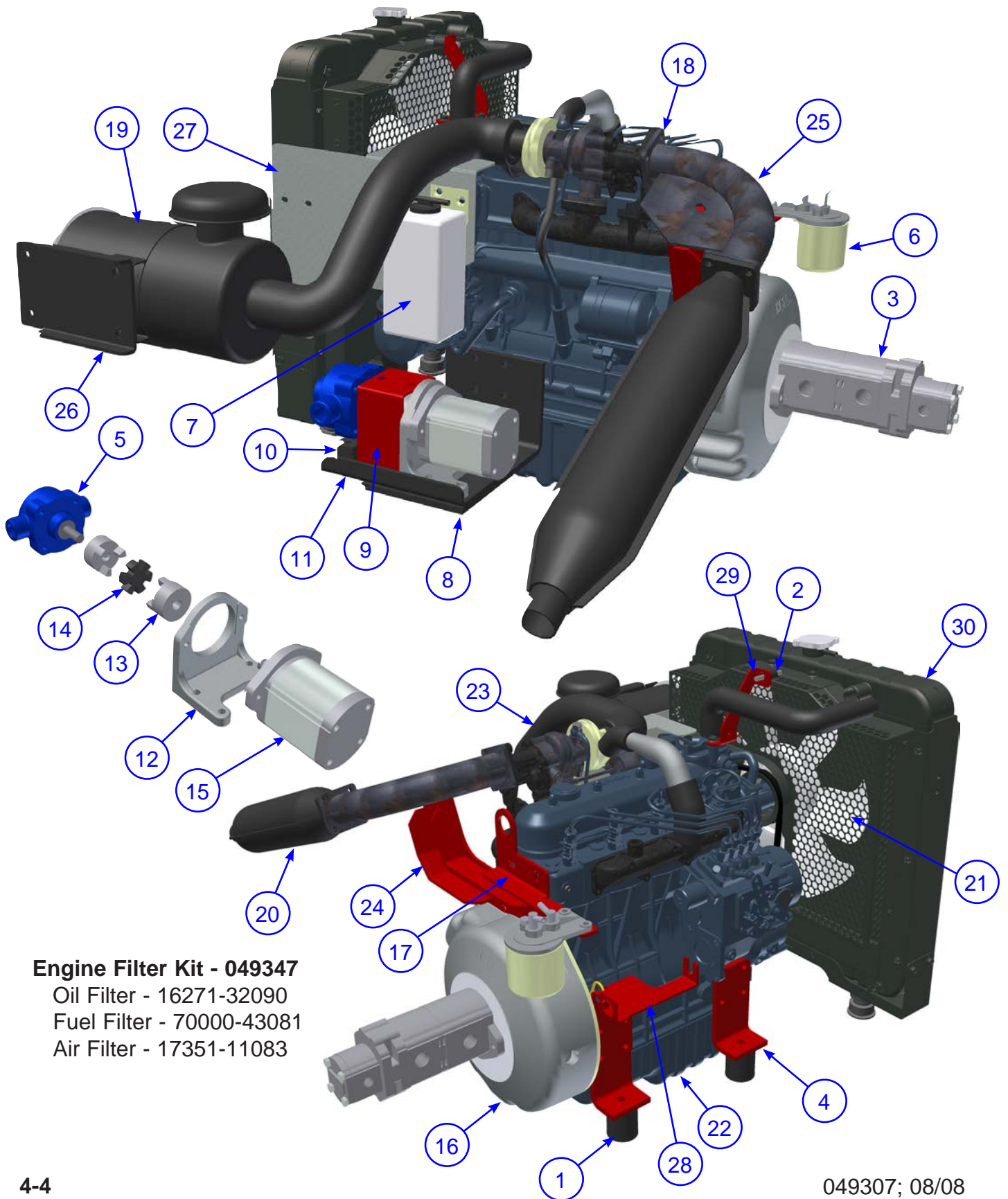

Engine Filter Kit - 049347
Oil Filter - 16271-32090
Fuel Filter - 70000-43081
Air Filter - 17351-11083

4.1 Parts List Power Unit Assembly

SECTION 4 PARTS

ITEM	PART #	DESCRIPTION	QTY
1	012725	ISOLATORS, RUBBER MOUNTS	4
2	028556	ISOLATOR, RUBBER	1
3	040062	PUMP, TANDEM TRTF	1
4	029245	BRACKET, ENGINE TRTF	3
5	029418	PUMP, HYPRO 6500C-R	1
6	037777	ASSY, FUEL FILTER	1
7	037791	TANK, OVERFLOW W/ BRACKET	1
8	039787	PLATE, MOUNT WATER PUMP TRTP	1
9	039788	GUARD, F/HYD. WATER PUMP TRTP	1
10	039789	SPACER, BLOCK F/WATER PUMP F/TRTP	1
11	039790	PLATE, F/HYD. MOTOR & H2O PUMP F/TRTP	1
12	040059	FOOT BRACKET, WATER PUMP TRTP	1
13	040060	COUPLER, JAW F/ WATER PUMP (TRTP)	2
14	040061	INSERT, JAW COUPLER WATER PUMP TRTP	1
15	040065	MOTOR, WATER PUMP (TRTP)	1
16	040905	KIT, HYD PUMP DRIVE ADAPTOR HAYES	1
17	041586	BRACKET, FUEL FILTER KUBOTA ENGINE	1
18	042338	GASKET, KUBOTA 38HP MUFFLER	2
19	043287	CLEANER, 44KB TURBO B53 AIR	1
20	043288	MUFFLER, 44KB TURBO C52	1
21	043289	FAN, 44KB TURBO 16299-74112 PUSHER	1
22	043291C	ENGINE, KUBOTA 44 TURBO V1505TE3BB-1	1
23	043393	HOSE, 44KB AIR CLEANER	1
24	046375	MUFFLER MOUNT BRKT	1
25	046379	TAIL PIPE	1
26	046382	BRACKET, AIR CLEANER MOUNT	1
27	046394	COVER, ALTERNATOR	1
28	048635	BRACKET, THROTTLE X1	1
29	049028	BRACKET, RAD SUPPORT MSP460 & HDX600	1
30	047874	RADIATOR, 44KBT TURBO A47 KIT	1

***Note: See section 6 for TRTP255 with Hatz engine, some part numbers may be different.**

SECTION 4 PARTS

4.2 Illustration Motor End

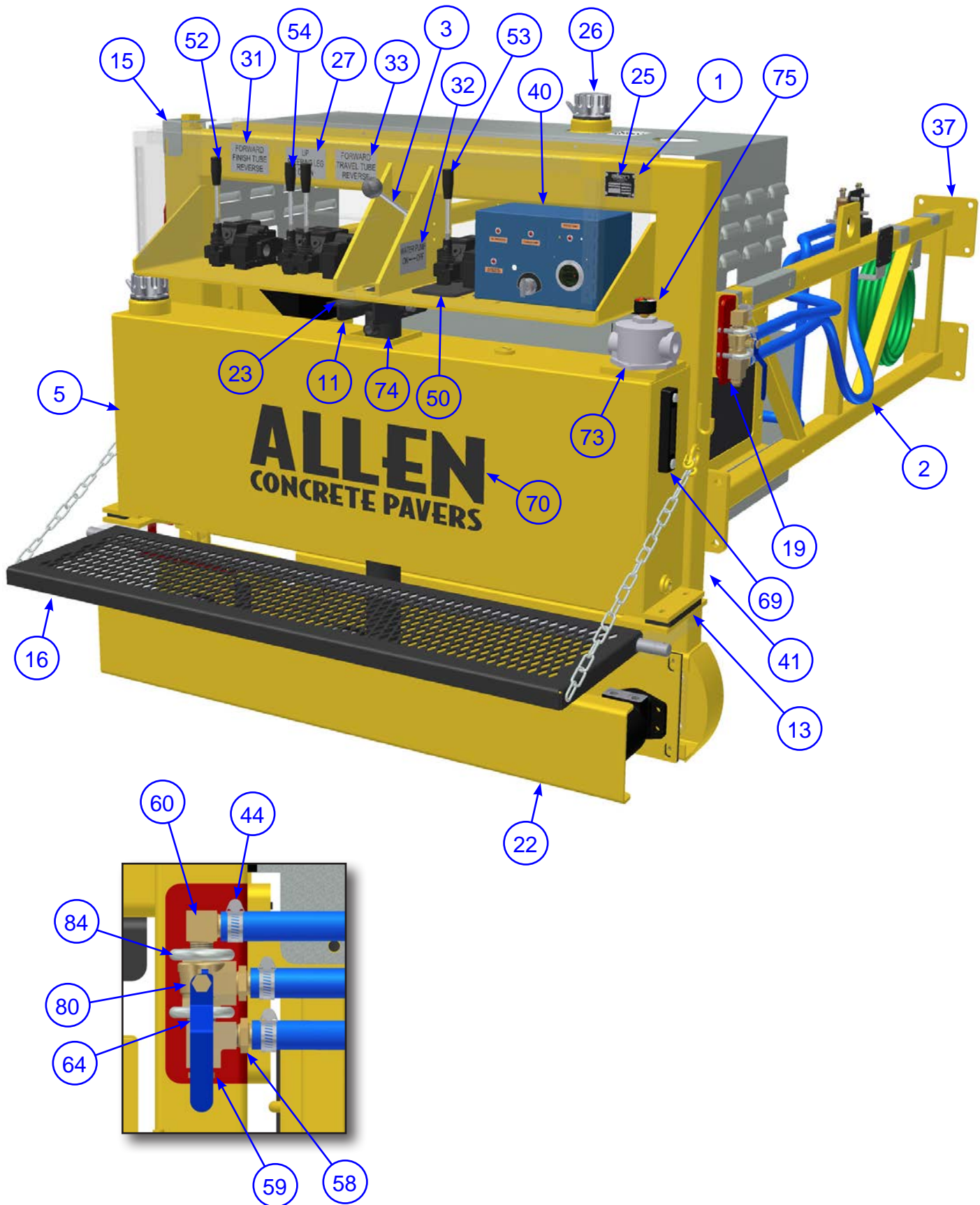

4.2 Parts List Motor End

SECTION 4 PARTS

ITEM	PART #	DESCRIPTION	QTY
1	012994	RIVET, 1/8x3/8 ALUM DOME HD	4
2	013394	HOSE, PUSHLOCK 3/4	50'
3	028018	CONTROL, HAND LEVER	1
	028243	ASSY, 52 LG THROTTLE CABLE	1
5	028269	TANK, HYD TRTF	1
6	028279	PLATE, MOUNT HYD MOTOR TRTF	3
7	028287	PAD, FOOT F/CYLINDER TRTF	1
8	028291-1	PIN, SHORT F/ CYLINDER TRTF	1
9	028291-2	PIN, LONG F/ CYLINDER TRTF	1
10	028292	SHAFT, HEX TRIPLE RTF	3
11	028322	MOUNT, CYLINDER TRTF	1
12	029059	BUSHING, FUEL TANK TRTF	2
13	029098	BUSHING, F/HYD TANK TRTF	2
14	029127	TANK, FUEL	1
15	029136	LOCK, F/ ENDHANDLE TRTF	1
16	029176	STAND, TRTF	1
17	029186	TUBE, MOUNT F/STAND TRTF	2
18	029187	BAR, F/STAND TRTF	1
19	029208	BRACKET, TRTP SHORT BALL VALVE	1
20	029213	BOX, BATTERY TRTF	1
21	029223	BEARING, MOTOR END 1 3/4 TRTF	3
22	029383	WELD'T, 255BD STD MOTOR PROTECTOR	1
23	029407	PLATE, LATCH (TRTF)	1
24	029459	HANGER, HOSE TRTF	2
25	032097	DECAL, SERIAL NUMBER PLATE	1
26	032268	UNIT, CHROME GAS-HYDR TANK CAP	2
27	032272	DECAL, STEERING TRTP	1
28	032273	DECAL, VERTICAL ADJ. TRTP	1
29	032275	DECAL, DIESEL FUEL ONLY	1
30	032276	DECAL, THROTTLE LEVER TRTP	1
31	032277	DECAL, FINISH TUBE TRTP	1
32	032278	DECAL, WATERPUMP ON/OFF TRTP	1
33	032279	DECAL, TRAVEL TUBE TRTP	1
34	034243	DECAL, HYDR OIL ONLY	1
35	037172	TAB, THROTTLE F/ALL 255 TRTF	1
36	037560	O-RING, HEX COUPLER ASSEMBLY	3
37	037577	FRAME, TRTP 6' END	2
38	037647	END EXTENSION F/ SPRAY BAR BRKT	2
39	037771	BATTERY, 12 V GRAY 655CA	1
40	037784	CONTROL BOX W/ WIRING HARNESS	1

*Note: See section 6 for TRTP255 with Hatz engine, some part numbers may be different.

SECTION 4 PARTS

4.2 Illustration Motor End (cont'd)

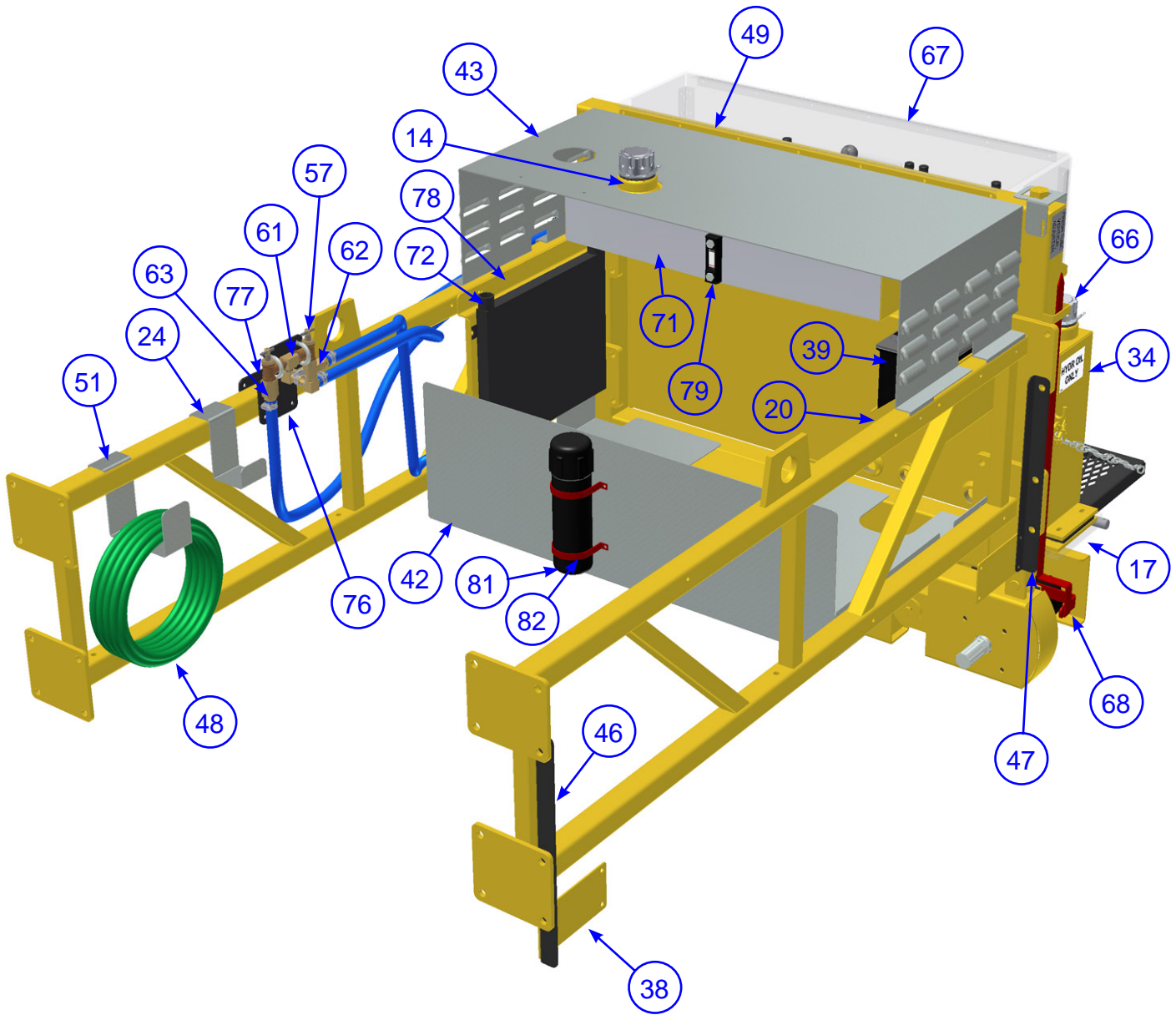

4.2 Parts List Motor End (cont'd)

SECTION 4 PARTS

ITEM	PART #	DESCRIPTION	QTY
41	038578	END HANDLE, 255BD MOTOR END	1
42	038582	PAN, MOD 255 BD ENGINE	1
43	038583	COVER, MOD 255BD ENGINE	1
44	038664	#10 HOSE CLAMP	8
45	038882	CUSHION,BATT.BOX REAR F/TRTF	1
46	038914L	BRACKET, SPRAY SYSTEM LH - 255	1
47	038914R	BRACKET, SPRAY SYSTEM RH - 255	1
48	038942	HOSE, TRTP 25' WATER	1
49	039344	PLATE, TRTP CONTROL COVER HINGE MTG	1
50	039792	VALVE, PLATE F/TRTP SPRAY SYSTEM	1
51	039826	HANGER, WATER HOSE FOR TRTP	1
52	040058	VALVE, STACK 7C7FTLFG/RF-SAE (TRTP)	1
53	040063	VALVE, SPRAY SYSTEM (TRTP)	1
54	040066	VALVE, STACK (TRAVEL CONTROL) TRTP	1
55	040067	MOTOR, 10" TRTP STND HYDR TRAVEL	2
56	040068	MOTOR, FINISH 10" TRTP (STRIKE OFF)	1
57	040107	RELIEF VALVE, TRTP SPRAY SYSTEM	2
58	038971	FTG, 3/4 MPT x 3/4 HOSE BARB	4
59	040109	FTG, 3/4 MPT x 3/4 GARDEN	1
60	040110	FTG, 3/4 MPT x 3/4 90° HOSE BARB	4
61	040111	FTG, 3/4 MPT RUN TEE	1
62	040114	FTG, 3/4 FPT TEE	1
63	040115	FTG, 3/4 COUPLER	1
64	040116	FTG, 3/4 CLOSE NIPPLE	3
65	040330	PUMP, 12 V ELECTRONIC FUEL	1
66	041509	DECAL, HYDRAULIC OIL CAP	1
67	042004	COVER, WELD'T CONTROL PANEL	1
68	042945	WELD'T POINTER MOTOR END 255 TRTP	1
69	043057	GAUGE, SNA HYDR LEVEL	1
70	043200	DECAL, ACP BLACK 7.5 X 22	1
71	043394	TAPE, HIGH TEMP FOIL 54' X 3" WIDE	.200
72	045133	COOLER, HYDRAULIC F/ TRTP	1
73	045134	FILTER, RETURN LINE RTF25N-D10B/S2/N	1
74	045136	CYLINDER, STEERING F/ TRTP	1
75	046241	GAUGE, CL-20 FILTER	1
76	046373	BRACKET, WATER VALVE MNT PLATE	1
77	046374	BRACKET, CLAMP PLATE WATER VALVE	1
78	046393	BRACKET, HYDRAULIC OIL COOLER MNT	1
79	047172	GAUGE, 3" SITE LEVEL	1
80	047412	VALVE, 3-WAY BALL 3/4"	1
81	066255	MANUAL TUBE, LARGE	1
82	-	N/A	-
83	049322	PLATE, SPACER F/ TRTP DRIVE MOTORS	3
84	116008	FSTN, CLAMP U-BOLT #320	4

SECTION 4
PARTS

4.2 Illustration
Motor End (cont'd)

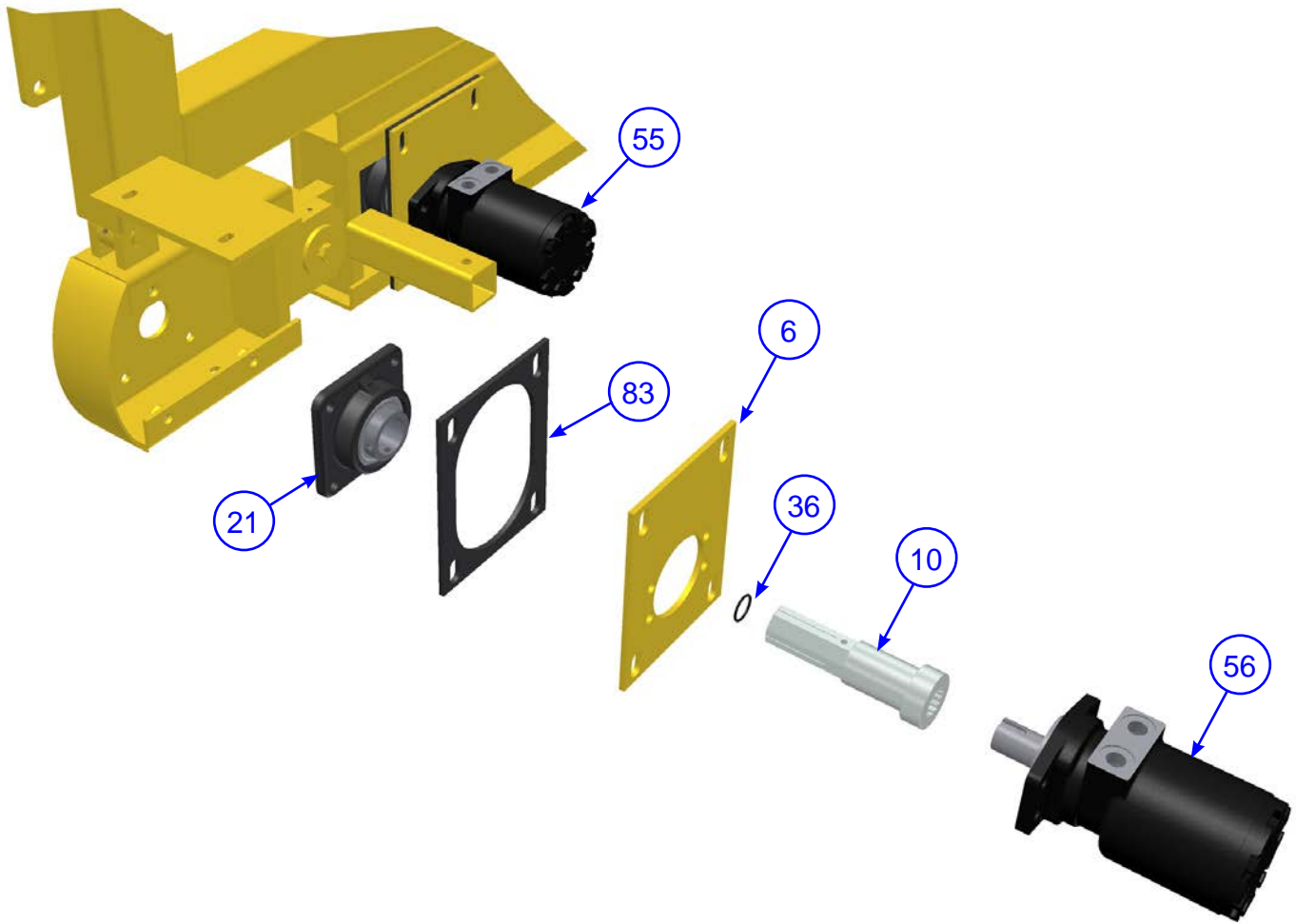

4.2 Parts List Motor End (cont'd)

SECTION 4 PARTS

ITEM	PART #	DESCRIPTION	QTY
6	028279	PLATE, MOUNT HYD MOTOR TRTF	3
10	028292	SHAFT, HEX TRIPLE RTF	3
21	029223	BEARING, MOTOR END 1 3/4 TRTF	3
36	037560	O-RING, HEX COUPLER ASSEMBLY	3
55	040067	MOTOR, 10" TRTP STND HYDR TRAVEL	2
56	040068	MOTOR, FINISH 10" TRTP (STRIKE OFF)	1
83	049322	PLATE, SPACER F/ TRTP DRIVE MOTORS	3

***Note: See section 6 for TRTP255 with Hatz engine, some part numbers may be different.**

SECTION 4 PARTS

4.3 Illustration Idle End

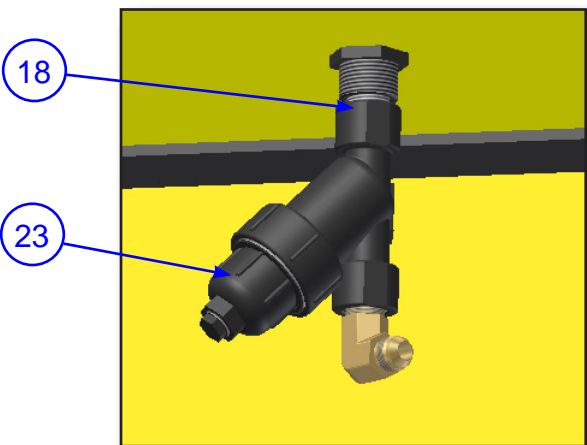
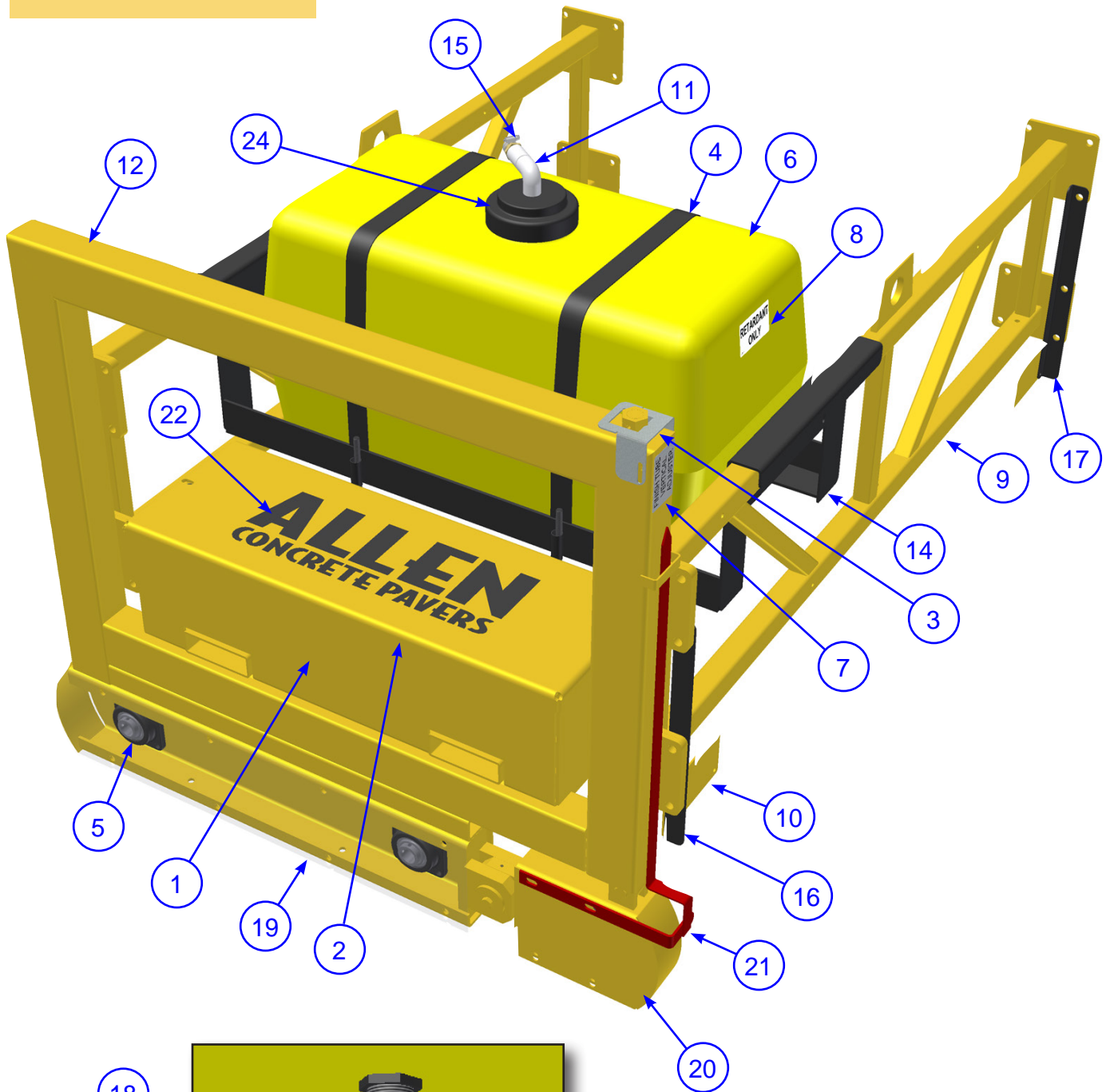

4.3 Parts List Idle End

SECTION 4 PARTS

ITEM	PART #	DESCRIPTION	QTY
1	029085	BOX, WEIGHT TRTF	1
2	029088	COVER, BOX WEIGHT TRTF	1
3	029136	LOCK, F/ END HANDLE TRTF	1
4	029139	STRAP, BARREL BRACKET TRTF	2
5	029222	BEARING IDLE END 1 1/4 TRTF	3
6	029317	TANK, WATER 55 GAL TTRF LOOSE 3/4FTG	1
7	032273	DECAL, VERTICAL ADJ. TRTP	1
8	036767	DECAL, RETARDANT ONLY	1
9	037577	FRAME, TRTP 6' END	2
10	037647	END EXTENSION F/SPRAY BAR BRKT	2
11	038233	ASSEMBLY, RETURN TUBE F/ TRTP	1
12	038577	END HANDLE, 255BD IDLE END	1
	038579	BASKET, MOD 255BD CENTER WELDT	1
14	038584	BRKT, MOD 255BD BARREL	1
15	038664	#10 HOSE CLAMP	1
16	038914L	BRACKET, SPRAY SYSTEM LH - 255	1
17	038914R	BRACKET, SPRAY SYSTEM RH - 255	1
18	040116	FTG, 3/4 CLOSE NIPPLE	1
19	042005	COVER, BASE FORWARD IDLE END (LARGE)	1
20	042006	COVER, BASE FORWARD IDLE END (SMALL)	1
21	042942	WELD'T POINTER IDLE END 255 TRTP	1
22	043200	DECAL, ACP BLACK 7.5 X 22	1
23	048382	Y-STRAINER, POLY 3/4 NPT F/ TRTP	1
24	049350	CAP, 55 GALLON TANK W/ HOLE F/ TRTP	1

SECTION 4 PARTS

4.6 Illustration Spray Bar Full Assembly

12 FT SPRAY BAR
ILLUSTRATION

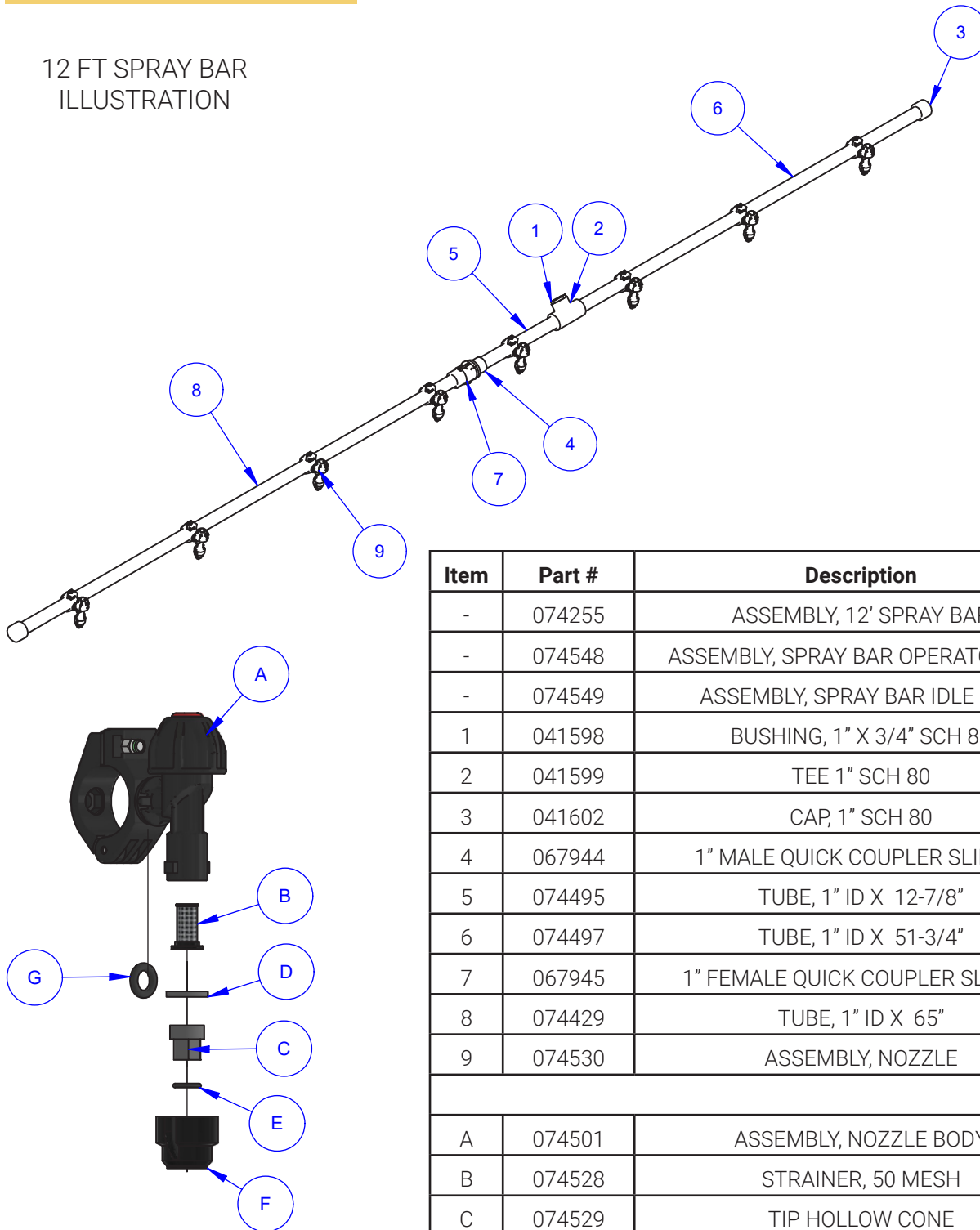

Item	Part #	Description	QTY
-	074255	ASSEMBLY, 12' SPRAY BAR	1
-	074548	ASSEMBLY, SPRAY BAR OPERATOR END	1
-	074549	ASSEMBLY, SPRAY BAR IDLE END	1
1	041598	BUSHING, 1" X 3/4" SCH 80	1
2	041599	TEE 1" SCH 80	1
3	041602	CAP, 1" SCH 80	2
4	067944	1" MALE QUICK COUPLER SLIP FIT	1
5	074495	TUBE, 1" ID X 12-7/8"	1
6	074497	TUBE, 1" ID X 51-3/4"	1
7	067945	1" FEMALE QUICK COUPLER SLIP FIT	1
8	074429	TUBE, 1" ID X 65"	1
9	074530	ASSEMBLY, NOZZLE	8
A	074501	ASSEMBLY, NOZZLE BODY	1
B	074528	STRAINER, 50 MESH	1
C	074529	TIP HOLLOW CONE	1
D	074531	GASKET, SEAT FOR SPRAY NOZZLE	1
E	074532	O-RING	1
F	074527	CAP FOR NOZZLE	1
G	075135	O-RING	1

4.6 Parts List Spray Bar Assemblies

SECTION 4 PARTS

TRTP 255 SPRAY BAR ASSEMBLY MATRIX			
MACHINE LENGTH	SPRAY BAR PART #	DESCRIPTION	QTY
12'	074255	ASSEMBLY, 12' SPRAY BAR	-
14'	074256	ASSEMBLY, 14' SPRAY BAR	-
16'	074257	ASSEMBLY, 16' SPRAY BAR	-
18'	074258	ASSEMBLY, 18' SPRAY BAR	-
20'	074259	ASSEMBLY, 20' SPRAY BAR	-
22'	074260	ASSEMBLY, 22' SPRAY BAR	-
24'	074261	ASSEMBLY, 24' SPRAY BAR	-
26'	074262	ASSEMBLY, 26' SPRAY BAR	-
28'	074263	ASSEMBLY, 28' SPRAY BAR	-
30'	074264	ASSEMBLY, 30' SPRAY BAR	-
32'	074266	ASSEMBLY, 32' SPRAY BAR	-
34'	074267	ASSEMBLY, 34' SPRAY BAR	-

NOTE: ALL SPRAY BAR ASSEMBLIES HAVE 074548 [A] AND 074549 [B] FOR THE OPERATOR AND IDLE ENDS.

TRTP 255 SPRAY BAR ASSEMBLY MATRIX	
MACHINE LENGTH	SCRAPER LENGTHS [FT]
12'	A-B
14'	A-1-1-B
16'	A-4-B
18'	A-1-4-1-B
20'	A-2-4-2-B
22'	A-3-4-3-B
24'	A-4-4-4-B
26'	A-5-4-5-B
28'	A-6-4-6-B
30'	A-3-4-4-4-3-B
32'	A-6-2-4-2-6-B
34'	A-5-4-4-4-5-B

SPRAY BAR INDIVIDUAL ASSEMBLIES	
Part #	Description
074548	[A] ASSEMBLY, SPRAY BAR OPERATOR END
074549	[B] ASSEMBLY, SPRAY BAR IDLE END
074432	ASSEMBLY, SPRAY BAR 1'
074444	ASSEMBLY, SPRAY BAR 2'
074546	ASSEMBLY, SPRAY BAR 3'
074441	ASSEMBLY, SPRAY BAR 4'
074565	ASSEMBLY, SPRAY BAR 5'
074498	ASSEMBLY, SPRAY BAR 6'

**SECTION 4
PARTS**

**4.5 Illustration
Frame Assembly**

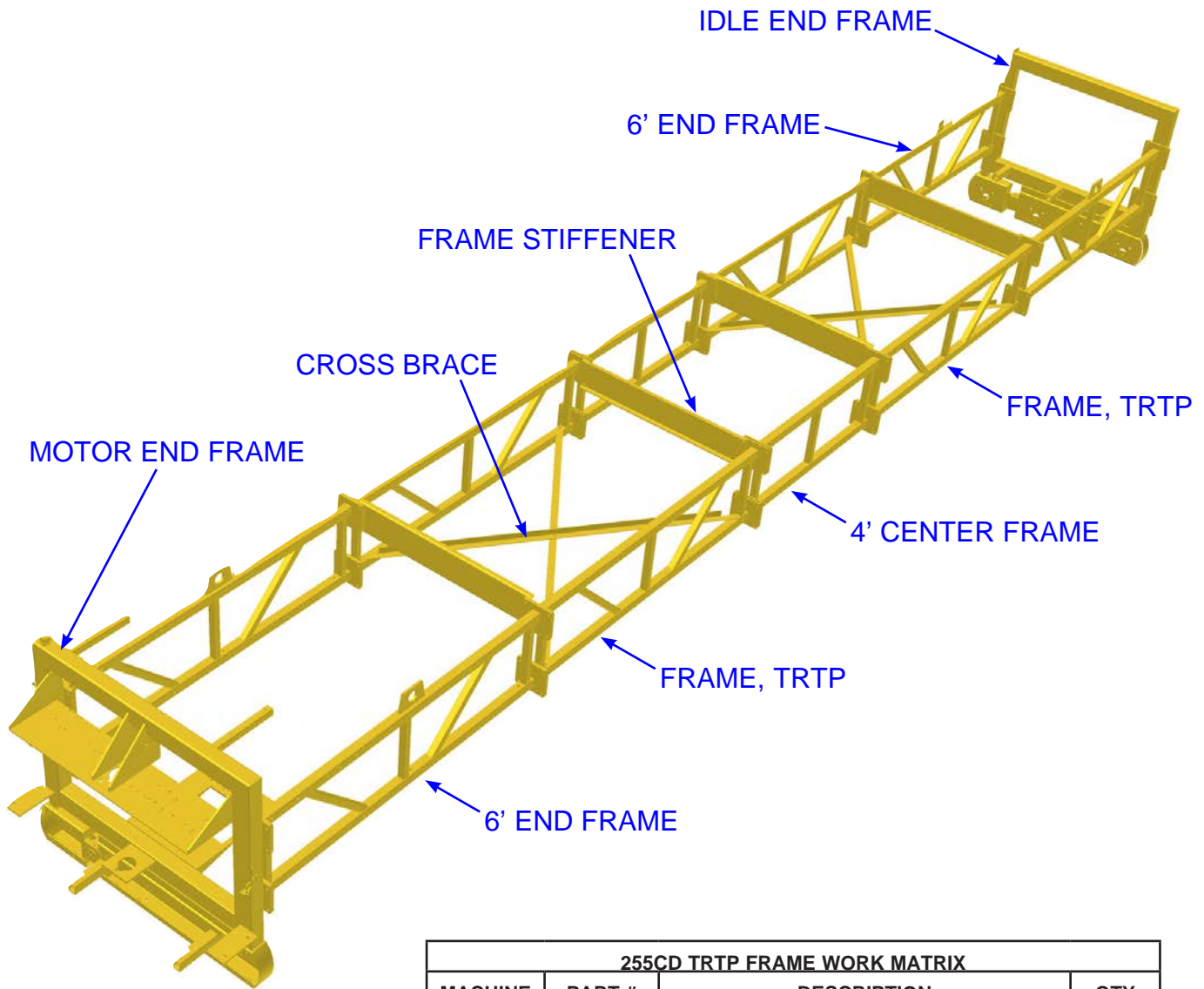

255CD TRTP FRAME WORK MATRIX			
MACHINE	PART #	DESCRIPTION	QTY
12'	037577	FRAME. TRTP 6' END	4
	029205	BRACKET. STIFFENER TRTF	1
14'	037577	FRAME. TRTP 6' END	4
	037569-18	FRAME. TRTP 1' SPACER	4
	029205	BRACKET. STIFFENER TRTF	2
16'	037577	FRAME. TRTP 6' END	4
	029205	BRACKET. STIFFENER TRTF	2
	037580	FRAME. TRTP 4' SPACER	2
18'	037577	FRAME. TRTP 6' END	4
	029205	BRACKET. STIFFENER TRTF	4
	037580	FRAME. TRTP 4' SPACER	2
	037569-18	FRAME. TRTP 1' SPACER	4

4.5 Parts List Frame Assembly

SECTION 4 PARTS

255CD TRTP FRAME WORK MATRIX (cont'd)			
MACHINE	PART #	DESCRIPTION	QTY
20'	037577	FRAME, TRTP 6' END	4
	029205	BRACKET, STIFFENER TRTF	4
	037569-20	FRAME, TRTP 2' SPACER	4
	037580	FRAME, TRTP 4' SPACER	2
22'	037577	FRAME, TRTP 6' END	4
	029205	BRACKET, STIFFENER TRTF	4
	037569-22	FRAME, TRTP 3' SPACER	4
	037580	FRAME, TRTP 4' SPACER	2
	038957-22	BRACE, CROSS (3'SPCR) - 255BD TRTP	4
24'	037577	FRAME, TRTP 6' END	4
	029205	BRACKET, STIFFENER TRTF	4
	037580	FRAME, TRTP 4' SPACER	6
	038957-24		4
26'	037577	FRAME, TRTP 6' END	4
	029205	BRACKET, STIFFENER TRTF	4
	037569-26	FRAME, TRTP 5' SPACER	4
	037580	FRAME, TRTP 4' SPACER	2
	038957-26	BRACE, CROSS (5'SPCR) - 255BD TRTP	4
28'	037577	FRAME, TRTP 6' END	4
	029205	BRACKET, STIFFENER TRTF	4
	037569-28	FRAME, TRTP 6' SPACER	4
	037580	FRAME, TRTP 4' SPACER	2
	038957-28	BRACE, CROSS (6'SPCR) - 255BD TRTP	4
30'	037577	FRAME, TRTP 6' END	4
	029205	BRACKET, STIFFENER TRTF	6
	037569-22	FRAME, TRTP 3' SPACER	4
	037580	FRAME, TRTP 4' SPACER	6
	038957-22	BRACE, CROSS (3'SPCR) - 255BD TRTP	4
	038957-24	BRACE, CROSS (4'SPCR) - 255BD TRTP	4
32'	037577	FRAME, TRTP 6' END	4
	029205	BRACKET, STIFFENER TRTF	6
	037569-20	FRAME, TRTP 2' SPACER	4
	037569-28	FRAME, TRTP 6' SPACER	4
	037580	FRAME, TRTP 4' SPACER	2
	038957-24	BRACE, CROSS (4'SPCR) - 255BD TRTP	8
34'	037577	FRAME, TRTP 6' END	4
	029205	BRACKET, STIFFENER TRTF	6
	037569-26	FRAME, TRTP 5' SPACER	4
	037580	FRAME, TRTP 4' SPACER	6
	038957-24	BRACE, CROSS (4'SPCR) - 255BD TRTP	4
	038957-26	BRACE, CROSS (5'SPCR) - 255BD TRTP	4

SECTION 4 PARTS

4.6 Illustration Scraper Full Assembly

12' Scraper Assembly
Example

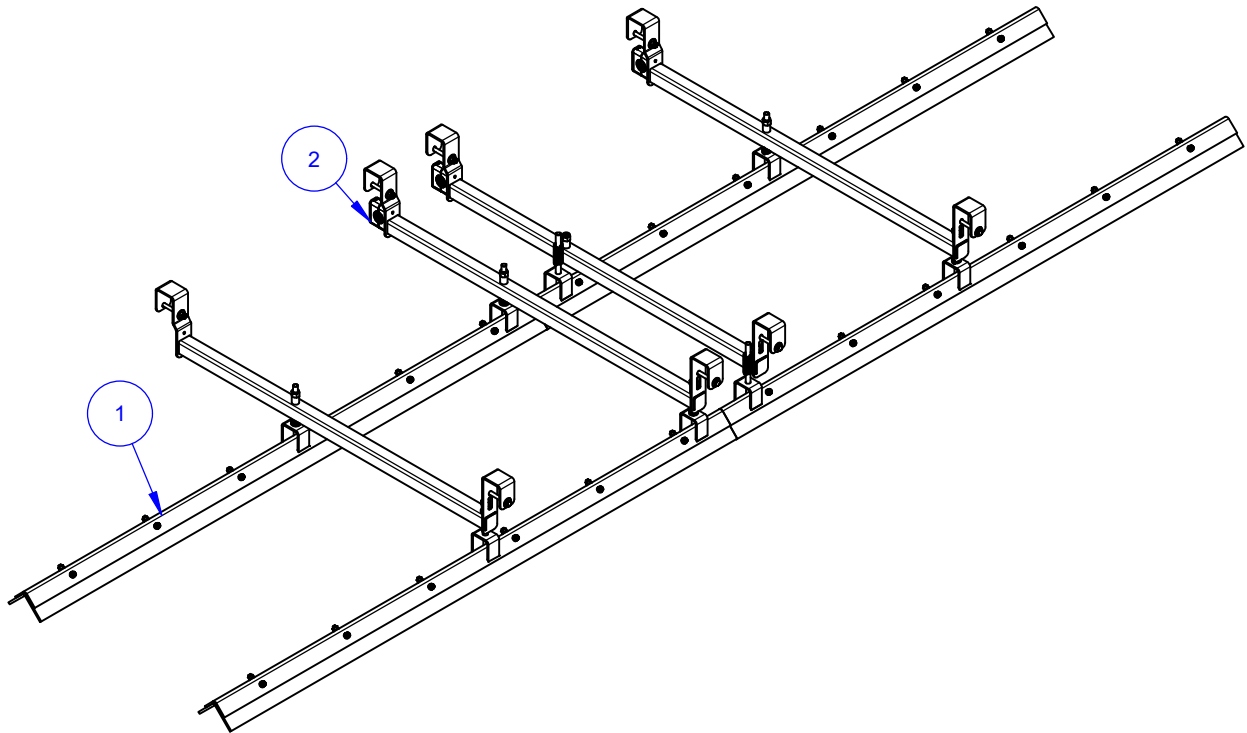

Item	Part #	Description	QTY
-	061412-12	ASSEMBLY, 12' SCRAPER	-
1	065858	ASSEMBLY, 6' SCRAPER END	2
2	051299	SPRAY BAR CLAMP	6

4.6 Parts List Scraper Assembly

SECTION 4 PARTS

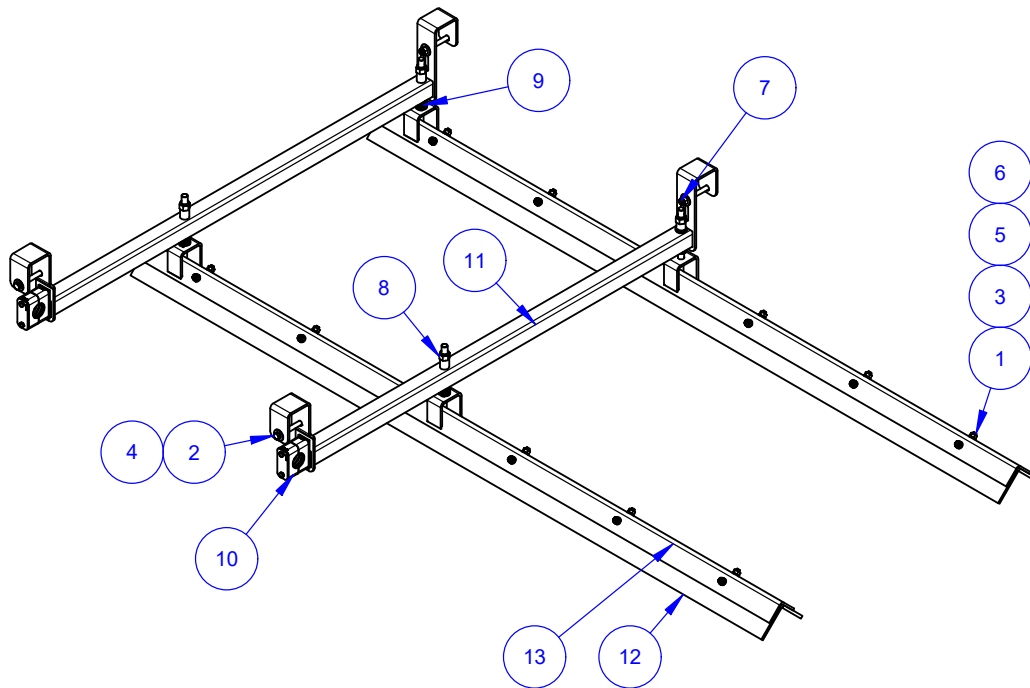

Item	Part #	Description	QTY
-	065858	SCRAPER ASSEMBLY, 6' END	-
1	010020	FASTENER, HHCS 5/16"-18 X 1"	24
2	010045	FASTENER, HHCS 3/8"-16 X 3-1/4"	4
3	010082	FASTENER, FLAT WASHER 5/16"	24
4	010083	FASTENER, FLAT WASHER 3/8"	8
5	010090	FASTENER, LOCK WASHER 5/16"	24
6	010100	FASTENER, HEX NUT 5/16"-18	24
7	010464	FASTENER, NYLOCK NUT 3/8"-16	4
8	011238	FASTENER, HEX NUT NYLOCK 1/2"-13	4
9	033936	SPRING F/ SCRAPER	4
10	051299	SPRAY BAR CLAMP	2
11	051652	WELDMENT, SCRAPER MOUNT	2
12	051655	SCRAPER 6' TIVAR	4
13	065859	WELDMENT, 6' SCRAPER ANGLE	2

SECTION 4 PARTS

4.6 Part List Scraper Full Assemblies

TRTP 255 SCRAPER FULL ASSEMBLY		
MACHINE LENGTH	SCRAPER PART #	DESCRIPTION
12'	061412-12	ASSEMBLY, 12' SCRAPER
14'	061412-14	ASSEMBLY, 14' SCRAPER
16'	061412-16	ASSEMBLY, 16' SCRAPER
18'	061412-18	ASSEMBLY, 18' SCRAPER
20'	061412-20	ASSEMBLY, 20' SCRAPER
22'	061412-22	ASSEMBLY, 22' SCRAPER
24'	061412-24	ASSEMBLY, 24' SCRAPER
26'	061412-26	ASSEMBLY, 26' SCRAPER
28'	061412-28	ASSEMBLY, 28' SCRAPER
30'	061412-30	ASSEMBLY, 30' SCRAPER
32'	061412-32	ASSEMBLY, 32' SCRAPER
34'	061412-34	ASSEMBLY, 34' SCRAPER

PART LENGTH	TIVAR PART #	DESCRIPTION
1'	053248	1' TIVAR F/ SCRAPER
2'	052748	2' TIVAR F/ SCRAPER
3'	051661	3' TIVAR F/ SCRAPER
4'	051664	4' TIVAR F/ SCRAPER
5'	051670	5' TIVAR F/ SCRAPER
6'	051655	6' TIVAR F/ SCRAPER

4.6 Parts List Scraper Individual Assemblies

SECTION 4 PARTS

TRTP 255 SCRAPER INDIVIDUAL ASSEMBLY MATRIX			
MACHINE LENGTH	SCRAPER PART #	DESCRIPTION	QTY
12'	065858	ASSEMBLY, 6' SCRAPER END	2
14'	065858	ASSEMBLY, 6' SCRAPER END	2
	052694	ASSEMBLY, 2' SCRAPER	1
16'	065858	ASSEMBLY, 6' SCRAPER END	2
	051662	ASSEMBLY, 4' SCRAPER	1
18'	065858	ASSEMBLY, 6' SCRAPER END	2
	051662	ASSEMBLY, 4' SCRAPER	1
	053245	ASSEMBLY, 1' SCRAPER	2
20'	065858	ASSEMBLY, 6' SCRAPER END	2
	051662	ASSEMBLY, 4' SCRAPER	1
	052694	ASSEMBLY, 2' SCRAPER	2
22'	065858	ASSEMBLY, 6' SCRAPER END	2
	051662	ASSEMBLY, 4' SCRAPER	1
	051658	ASSEMBLY, 3' SCRAPER	2
24'	065858	ASSEMBLY, 6' SCRAPER END	2
	051662	ASSEMBLY, 4' SCRAPER	3
26'	065858	ASSEMBLY, 6' SCRAPER END	2
	051662	ASSEMBLY, 4' SCRAPER	1
	051672	ASSEMBLY, 5' SCRAPER	2
28'	065858	ASSEMBLY, 6' SCRAPER END	2
	051662	ASSEMBLY, 4' SCRAPER	1
	051656	ASSEMBLY, 6' SCRAPER	2
30'	065858	ASSEMBLY, 6' SCRAPER END	2
	051662	ASSEMBLY, 4' SCRAPER	3
	051658	ASSEMBLY, 3' SCRAPER	2
32'	065858	ASSEMBLY, 6' SCRAPER END	2
	051662	ASSEMBLY, 4' SCRAPER	1
	051656	ASSEMBLY, 6' SCRAPER	2
	052694	ASSEMBLY, 2' SCRAPER	2
34'	065858	ASSEMBLY, 6' SCRAPER END	2
	051662	ASSEMBLY, 4' SCRAPER	3
	051672	ASSEMBLY, 5' SCRAPER	2

**SECTION 4
PARTS**

**4.7 Illustration
Front Walkway Assembly**

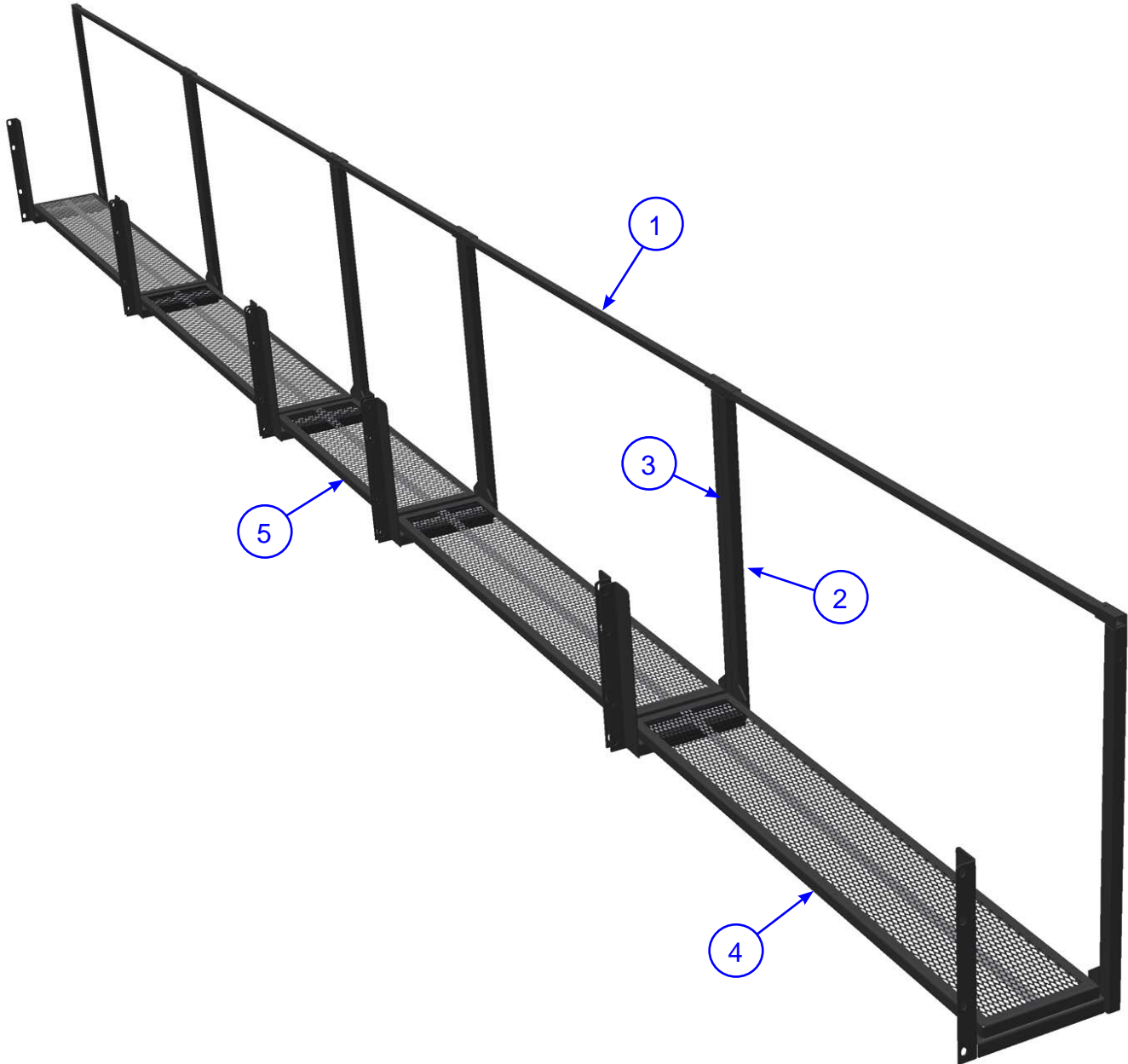

4.7 Parts List Front Walkway Assembly

SECTION 4 PARTS

ITEM	PART #	DESCRIPTION	QTY
1	033585-1	TUBE, RAIL TOP (1'SPCR)	-
	033585-2	TUBE, RAIL TOP (2'SPCR)	-
	033585-3	TUBE, RAIL TOP (3'SPCR)	-
	033585-4	TUBE, RAIL TOP (4'SPCR)	-
	033585-5	TUBE, RAIL TOP (5'SPCR)	-
	033587	TUBE, TOP RAIL (6' END)	2
2	037594L	WELD'T FRONT WALKWAY BRKT. LH	-
3	037594R	WELD'T FRONT WALKWAY BRKT. RH	-
4	038812	WELD'T, TRTP END WALKWAY	2
5	038816	WELD'T, TRTP 4' WALKWAY	-
	038840	WELD'T, TRTP 6' WALKWAY	-
	038824	WELD'T, TRTP 2' WALKWAY	-
	038820	WELD'T, TRTP 1' WALKWAY	-
	038828	WELD'T, TRTP 3' WALKWAY	-
	038836	WELD'T, TRTP 5' WALKWAY	-

Front Walkway Assemblies

PART #	DESCRIPTION
037599-12	WALKWAY, FRONT 12' 200BD/255BD
037599-14	WALKWAY, FRONT 14' 200BD/255BD
037599-16	WALKWAY, FRONT 16' 200BD/255BD
037599-18	WALKWAY, FRONT 18' 200BD/255BD
037599-20	WALKWAY, FRONT 20' 200BD/255BD
037599-22	WALKWAY, FRONT 22' 200BD/255BD
037599-24	WALKWAY, FRONT 24' 200BD/255BD
037599-26	WALKWAY, FRONT 26' 200BD/255BD
037599-28	WALKWAY, FRONT 28' 200BD/255BD
037599-30	WALKWAY, FRONT 30' 200BD/255BD
037599-32	WALKWAY, FRONT 32' 200BD/255BD
037599-34	WALKWAY, FRONT 34' 200BD/255BD

**SECTION 4
PARTS**

**4.8 Illustration
Rear Walkway Assembly**

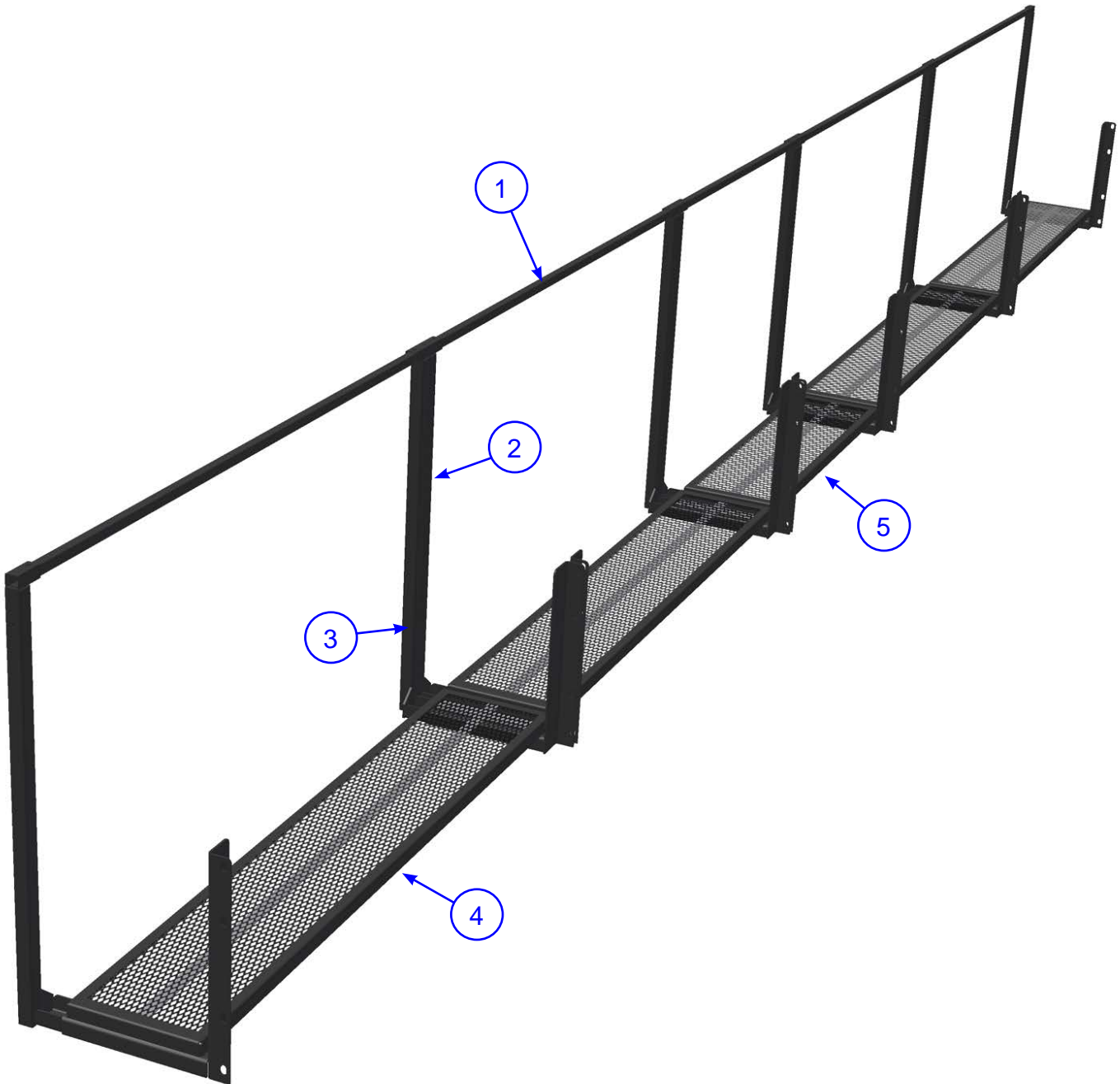

4.8 Parts List Rear Walkway Assembly

SECTION 4 PARTS

ITEM	PART #	DESCRIPTION	QTY
1	033585-1	TUBE, RAIL TOP (1'SPCR)	-
	033585-2	TUBE, RAIL TOP (2'SPCR)	-
	033585-3	TUBE, RAIL TOP (3'SPCR)	-
	033585-4	TUBE, RAIL TOP (4'SPCR)	-
	033585-5	TUBE, RAIL TOP (5'SPCR)	-
	033587	TUBE, TOP RAIL (6' END)	2
2	037601L	WELD'T REAR WALKWAY LEFT	-
3	037601R	WELD'T REAR WALKWAY RIGHT	-
4	038812	WELD'T, TRTP END WALKWAY	2
5	038816	WELD'T, TRTP 4' WALKWAY	-
	038840	WELD'T, TRTP 6' WALKWAY	-
	038824	WELD'T, TRTP 2' WALKWAY	-
	038820	WELD'T, TRTP 1' WALKWAY	-
	038828	WELD'T, TRTP 3' WALKWAY	-
	038836	WELD'T, TRTP 5' WALKWAY	-

Rear Walkway Assemblies

PART #	DESCRIPTION
037597-12	WALKWAY, REAR 12' 200BD/255BD
037597-14	WALKWAY, REAR 14' 200BD/255BD
037597-16	WALKWAY, REAR 16' 200BD/255BD
037597-18	WALKWAY, REAR 18' 200BD/255BD
037597-20	WALKWAY, REAR 20' 200BD/255BD
037597-22	WALKWAY, REAR 22' 200BD/255BD
037597-24	WALKWAY, REAR 24' 200BD/255BD
037597-26	WALKWAY, REAR 26' 200BD/255BD
037597-28	WALKWAY, REAR 28' 200BD/255BD
037597-30	WALKWAY, REAR 30' 200BD/255BD
037597-32	WALKWAY, REAR 32' 200BD/255BD
037597-34	WALKWAY, REAR 34' 200BD/255BD

**SECTION 4
PARTS**

**4.9 Illustration
Ballast Tube Assembly**

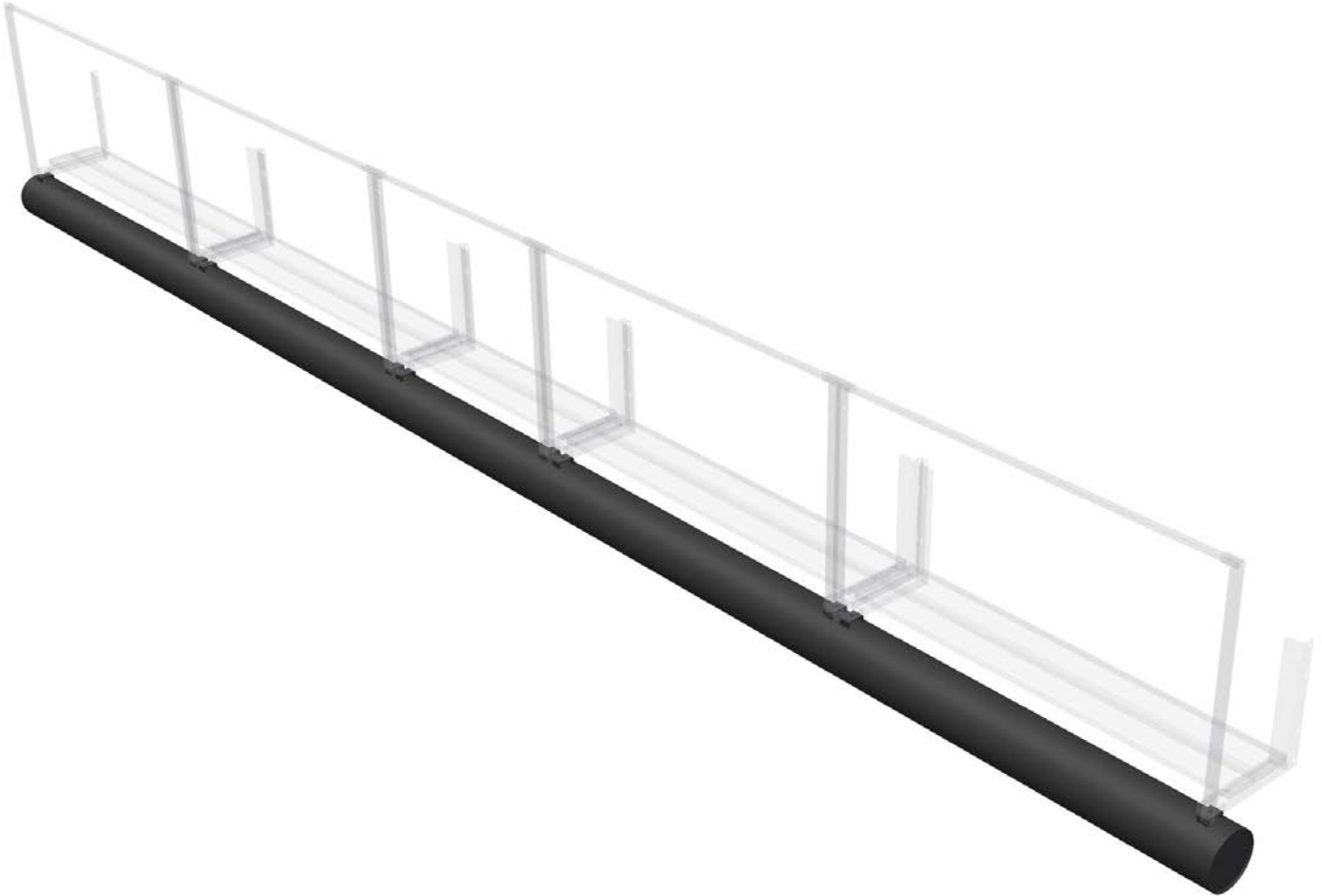

4.9 Parts List Ballast Tube Assembly

SECTION 4 PARTS

Ballast Tubes

PART #	DESCRIPTION
034003-12	BALLAST, WATER TUBE 12'
034003-14	BALLAST, WATER TUBE 14'
034003-16	BALLAST, WATER TUBE 16'
034003-18	BALLAST, WATER TUBE 18'
034003-20	BALLAST, WATER TUBE 20'
034003-22	BALLAST, WATER TUBE 22'
034003-24	BALLAST, WATER TUBE 24'
034003-26	BALLAST, WATER TUBE 26'
034003-28	BALLAST, WATER TUBE 28'
034003-30	BALLAST, WATER TUBE 30'
034003-32	BALLAST, WATER TUBE 32'
034003-34	BALLAST, WATER TUBE 34'

NOTE

A rear walkway must be installed on the machine prior to installing a ballast tube.

**SECTION 4
PARTS**

**4.10 Illustration
Hydraulic Schematic**

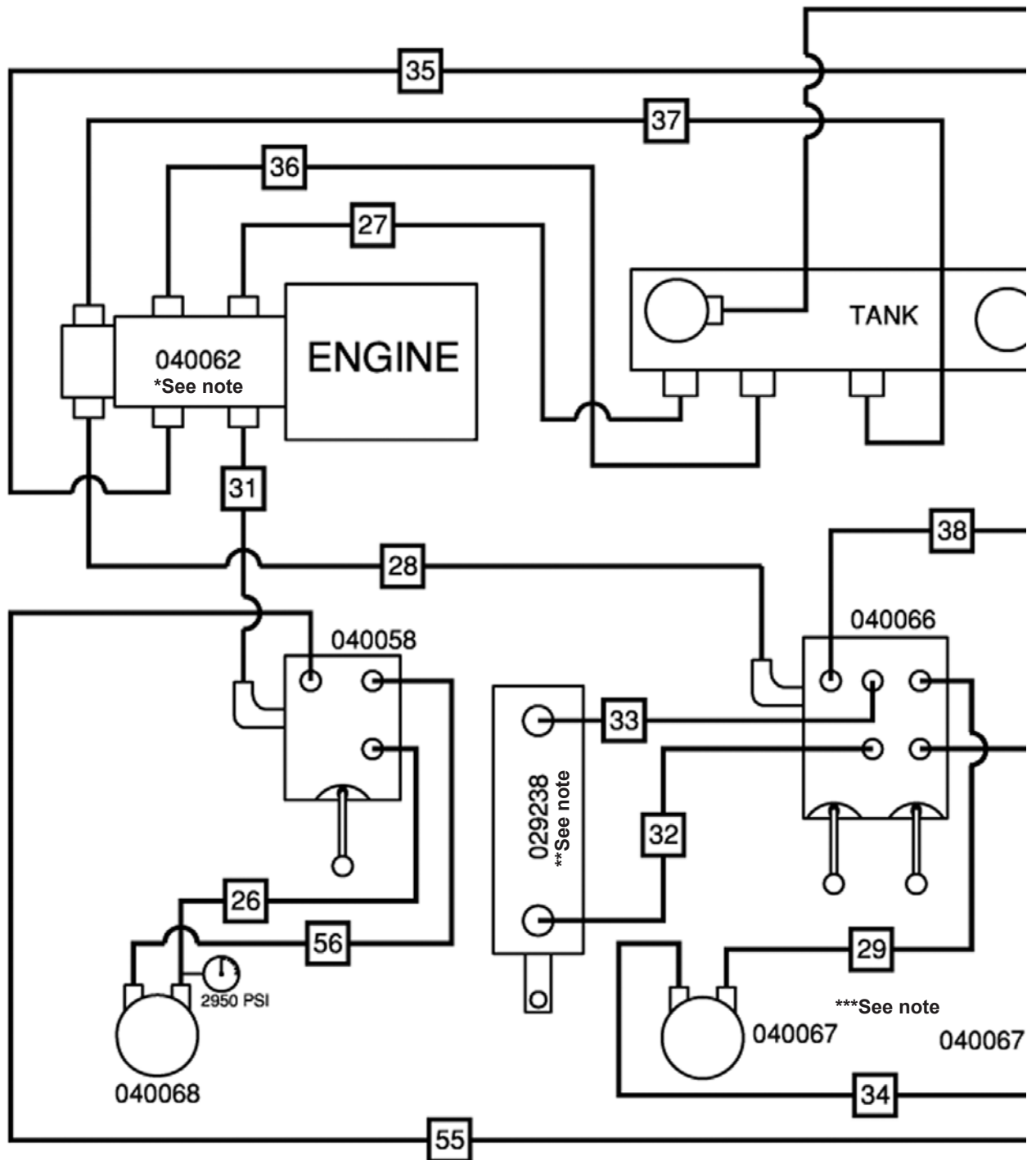

Note: See section 6 for TRTP255 with Hatz engine, some part numbers may be different.

*For TRTP255 with Hatz engine, use 074283 pump.

**For 029238 use PN 045136 instead.

***For TRTP255 with Hatz engine, use 044652 travel motor.

4.10 Illustration Hydraulic Schematic

SECTION 4 PARTS

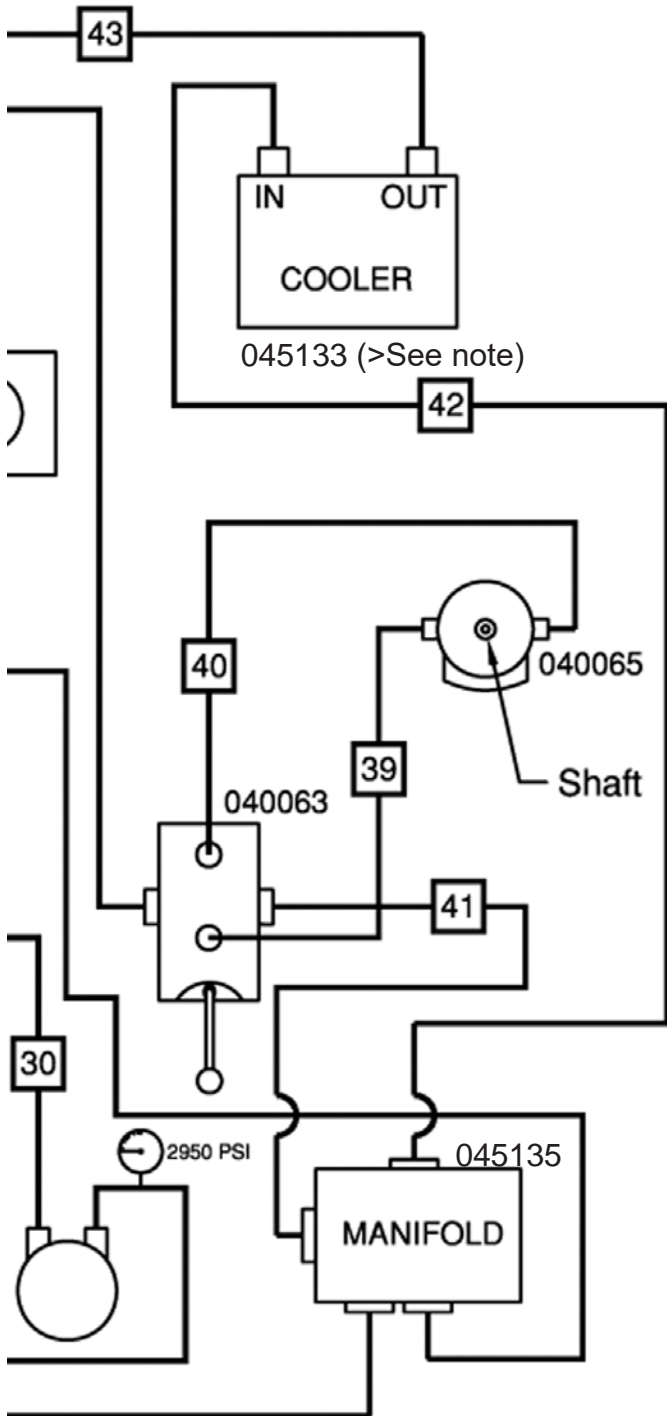

PART #	DESCRIPTION	QTY
040086	HOSE ASSEMBLY, 10" TRTP (#26)	1
040087	HOSE ASSEMBLY, 10" TRTP (#27)	1
040088	HOSE ASSEMBLY, 10" TRTP (#28)	1
040089	HOSE ASSEMBLY, 10" TRTP (#29)	1
040090	HOSE ASSEMBLY, 10" TRTP (#30)	1
040091	HOSE ASSEMBLY, 10" TRTP (#31)	1
040092	HOSE ASSEMBLY, 10" TRTP (#32)	1
040093	HOSE ASSEMBLY, 10" TRTP (#33)	1
040094	HOSE ASSEMBLY, 10" TRTP (#34)	1
040095	HOSE ASSEMBLY, 10" TRTP (#35)	1
040096	HOSE ASSEMBLY, 10" TRTP (#36)	1
040097	HOSE ASSEMBLY, 10" TRTP (#37)	1
040098	HOSE ASSEMBLY, 10" TRTP (#38)	1
040099	HOSE ASSEMBLY, 10" TRTP (#39)	1
040100	HOSE ASSEMBLY, 10" TRTP (#40)	1
040101	HOSE ASSEMBLY, 10" TRTP (#41)	1
040102	HOSE ASSEMBLY, 10" TRTP (#55)	1
040103	HOSE ASSEMBLY, 10" TRTP (#56)	1
047093	HOSE ASSEMBLY, 10" TRTP (#42)	1
047094	HOSE ASSEMBLY, 10" TRTP (#43)	1

Note: See section 6 for TRTP255 with Hatz engine, some part numbers may be different.
>For TRTP255 with Hatz engine, use 047693 cooler.

SECTION 4 PARTS

4.11 Illustration Wiring Schematic

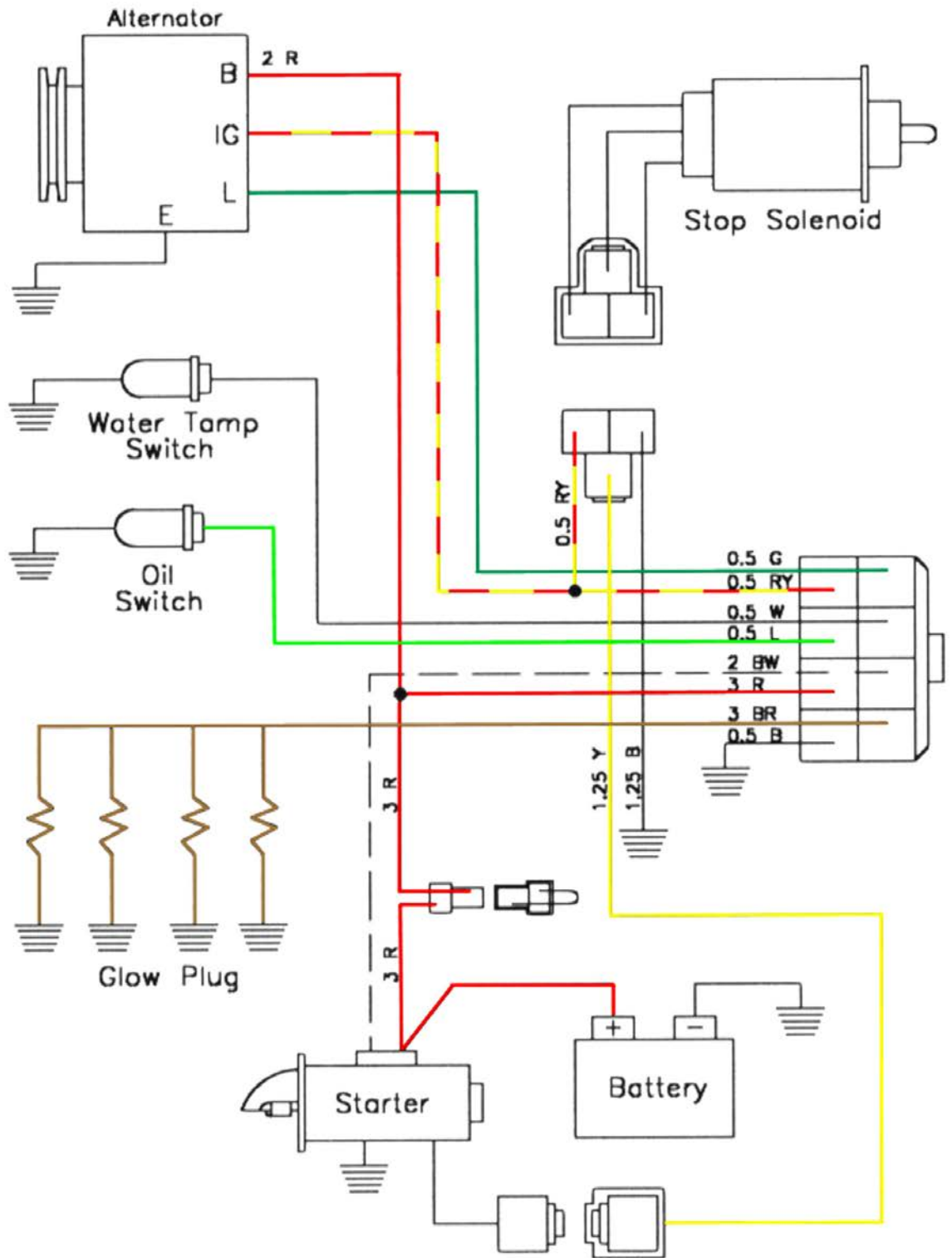

4.11 Illustration Wiring Schematic

SECTION 4 PARTS

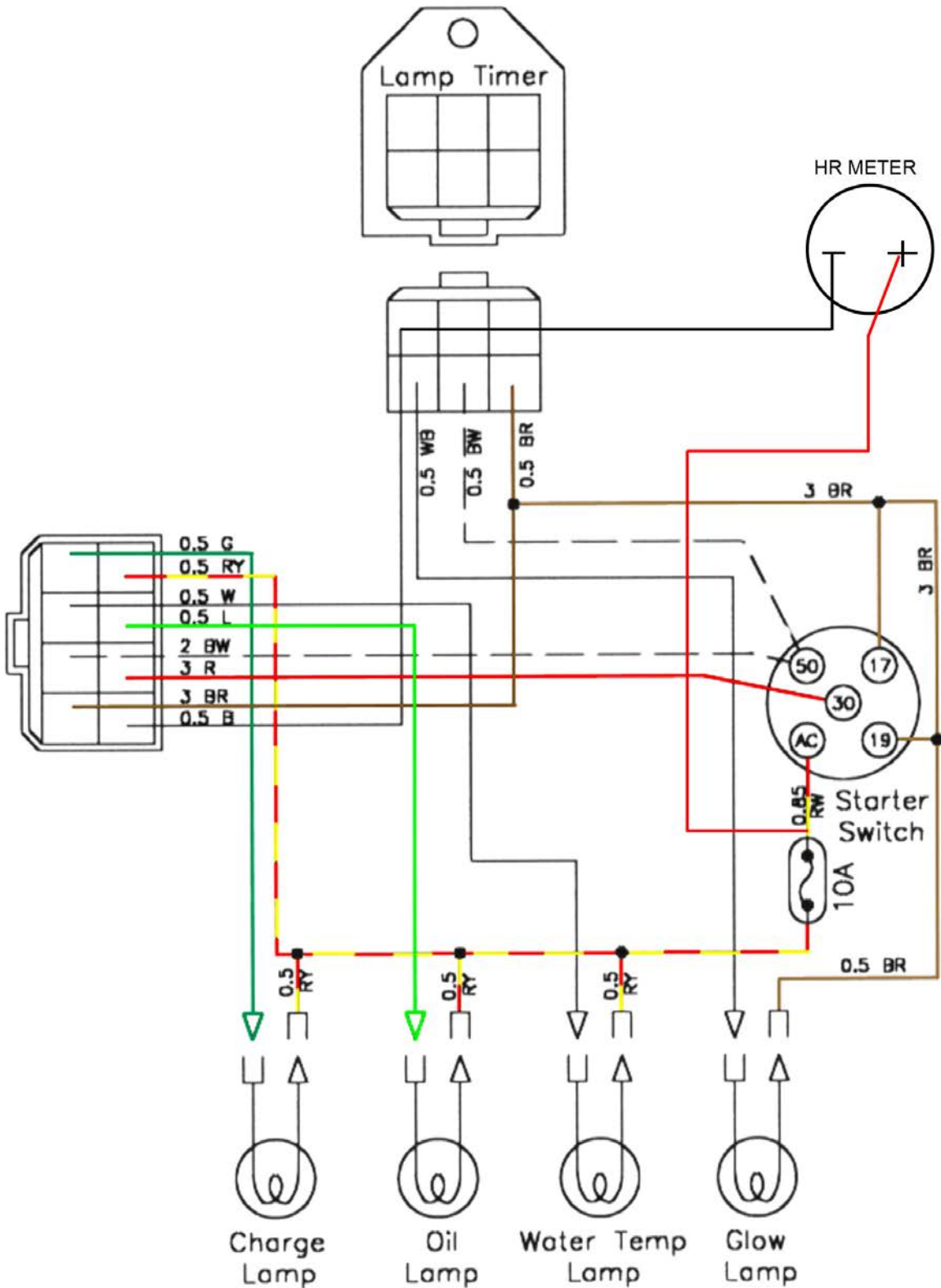

**SECTION 4
PARTS**

**4.12 Illustration
Idle End Grease Fittings (Oct 2014)**

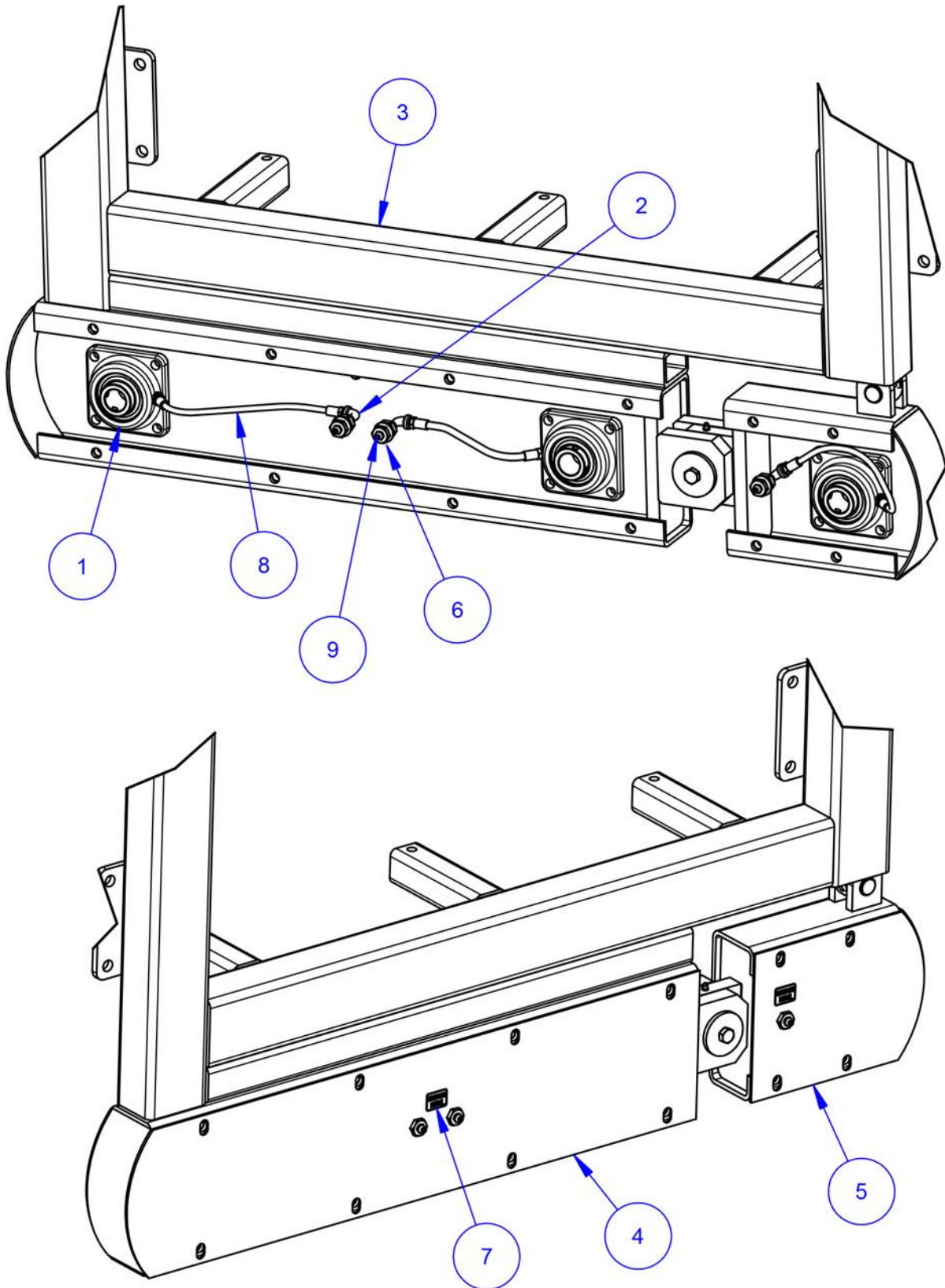

4.12 Parts List Idle End Grease Fittings (Oct 2014)

SECTION 4 PARTS

ITEM	PART NO.	DESCRIPTION	QTY
1	029222	IDLE END BEARING	3
2	034389	ELBOW, 1/8-27 NPT 90° GALV ST	3
3	038577	END HANDLE, 255BD IDLE END	1
4	042005	COVER, BASE FORWARD FOR IDLE END HANDLE 255 TRTF	1
5	042006	COVER, BASE FORWARD IDLE END (SMALL) 255 TRTF	1
6	062423	FTG, BULK HEAD 1/8" NPT X 5/8-18 OD THREADS BRASS	3
7	062921	DECAL, GREASE HERE	2
8	063085	HOSE, 18" LONG FLEXIBLE GREASE W/ 1/8	3
9	201163	FITTING, 1/8-27 PTF STR GREASE	3

SECTION 4 PARTS

24' Access Platform Assembly Illustration

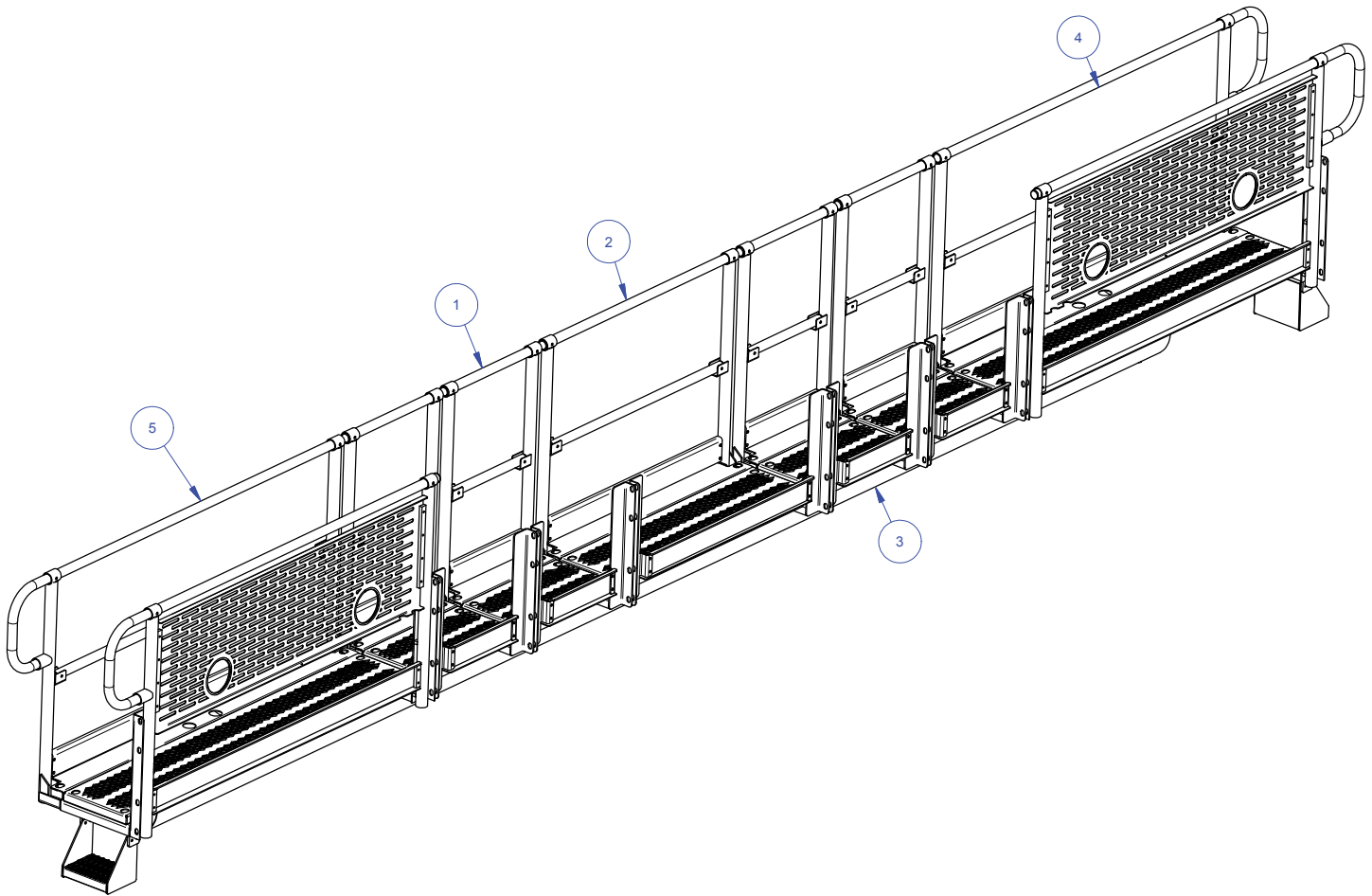

24' Access Platform Assembly Parts List

SECTION 4 PARTS

ITEM	PART NO.	DESCRIPTION	QTY
1	2'	2' ACCESS PLATFORM Assembly	4
2	4'	4' ACCESS PLATFORM Assembly	1
3	2726-025	BALLAST TUBE, 20'	1
4	LH	End ACCESS PLATFORM LH	1
5	RH	End ACCESS PLATFORM RH	1

SECTION 4 PARTS

RH End Access Platform Assembly Illustration

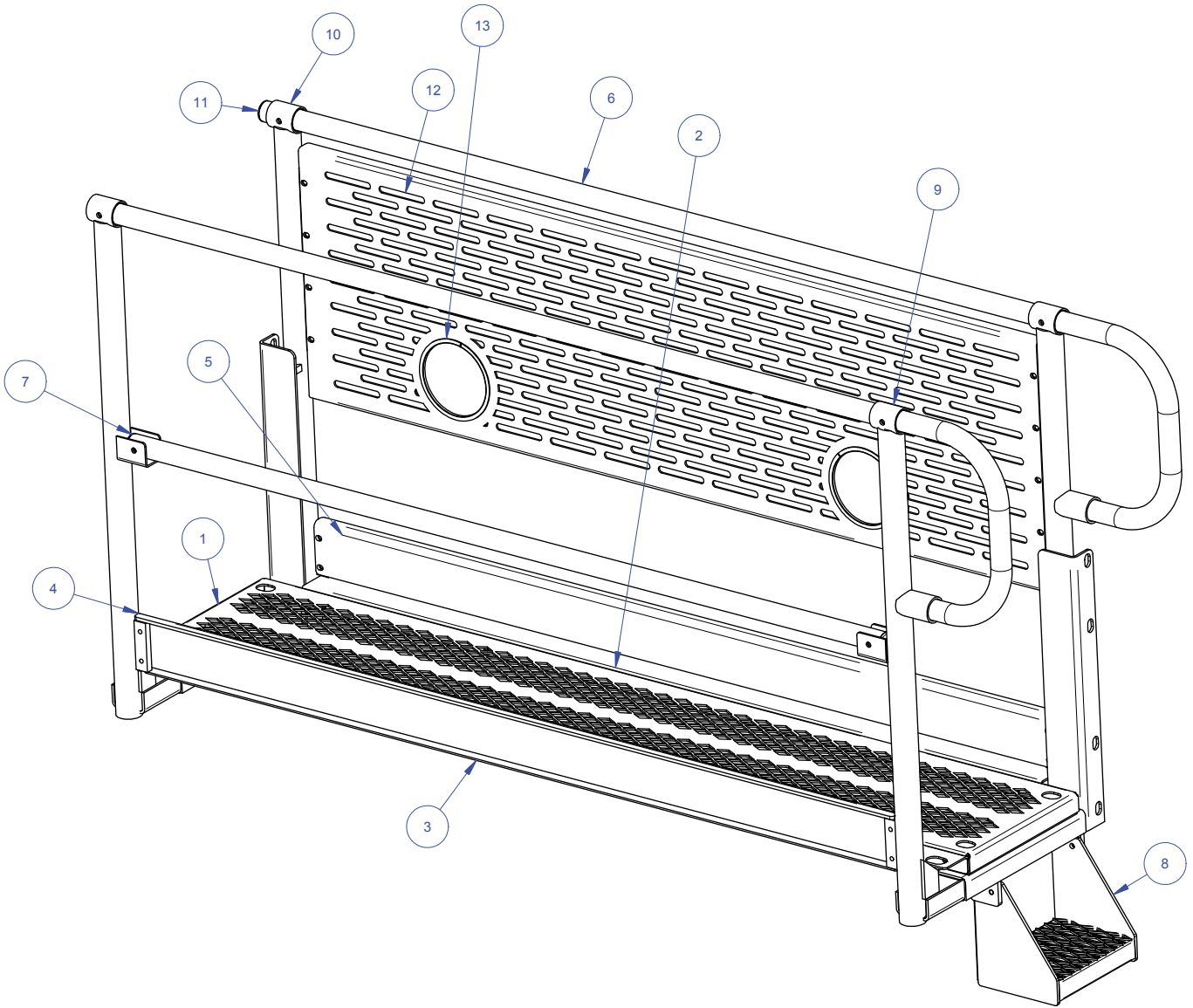

RH End Access Platform Assembly Parts List

SECTION 4 PARTS

ITEM	PART NO.	DESCRIPTION	QTY
1	067028	WELD'T, TRTP END ACCESS PLATFORM (AUS)	1
2	067030	EXTENSION, INSIDE END ACCESS PLATFORM (AUS)	1
3	067031	EXTENSION WELDMENT, OUTSIDE END ACCESS PLATFORM (AUS)	1
4	067034	KICK PLATE, OUTSIDE END ACCESS PLATFORM (AUS)	1
5	067035	KICK PLATE, INSIDE END ACCESS PLATFORM (AUS)	1
6	067037	TOP RAIL TUBE F/ END ACCESS PLATFORM (AUS)	2
7	067040	TUBE, MIDDLE RAIL F/ END ACCESS PLATFORM (AUS)	1
8	067044	END STEP WELDMENT (AUS)	1
9	067045	RH OUTSIDE END ACCESS PLATFORM WELDMENT (AUS)	1
10	067046	RH INSIDE END ACCESS PLATFORM WELDMENT (AUS)	1
11	067057	PLUG, 9283K34 F/ RAIL TUBES (AUS)	6
12	067143	GUARD, LH ENGINE F/ END ACCESS PLATFORM (AUS)	1
13	067171	RUBBER U-CHANNEL PUSH ON TRIM	2

SECTION 4 PARTS

LH End Access Platform Assembly Illustration

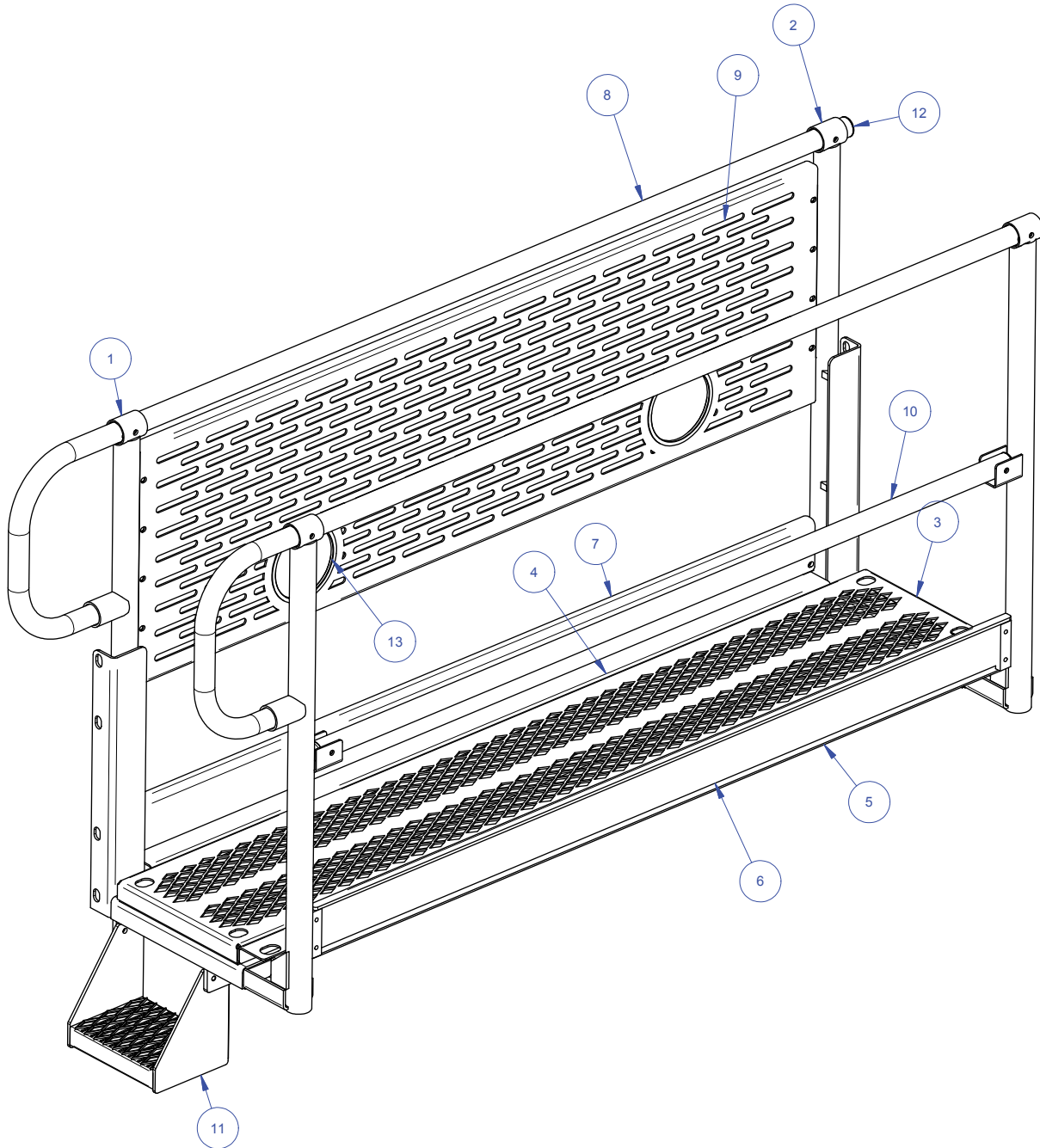

LH End Access Platform Assembly Parts List

SECTION 4 PARTS

ITEM	PART NO.	DESCRIPTION	QTY
1	067018	LH OUTSIDE END ACCESS PLATFORM WELDMENT (AUS)	1
2	067027	LH INSIDE END ACCESS PLATFORM WELDMENT (AUS)	1
3	067028	WELD'T, TRTP END ACCESS PLATFORM (AUS)	1
4	067030	EXTENSION, INSIDE END ACCESS PLATFORM (AUS)	1
5	067031	EXTENSION WELDMENT, OUTSIDE END ACCESS PLATFORM (AUS)	1
6	067034	KICK PLATE, OUTSIDE END ACCESS PLATFORM (AUS)	1
7	067035	KICK PLATE, INSIDE END ACCESS PLATFORM (AUS)	1
8	067037	TOP RAIL TUBE F/ END ACCESS PLATFORM (AUS)	2
9	067039	GUARD, RH ENGINE F/ END ACCESS PLATFORM (AUS)	1
10	067040	TUBE, MIDDLE RAIL F/ END ACCESS PLATFORM (AUS)	1
11	067044	END STEP WELDMENT (AUS)	1
12	067057	PLUG, 9283K34 F/ RAIL TUBES (AUS)	6
13	067171	RUBBER U-CHANNEL PUSH ON TRIM	2

SECTION 4 PARTS

4' Access Platform Assembly Illustration

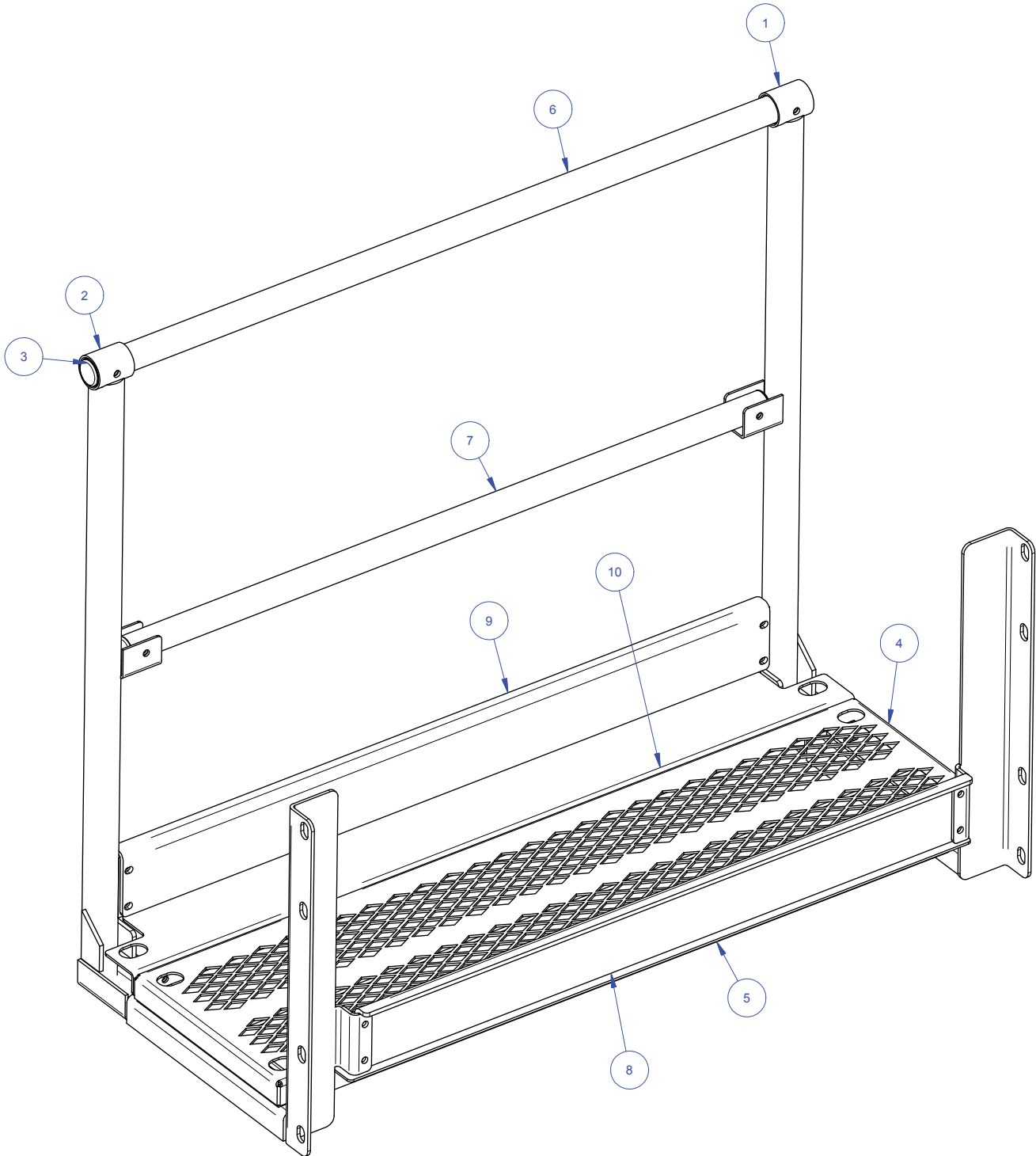

4' Access Platform Assembly Parts List

SECTION 4 PARTS

ITEM	PART NO.	DESCRIPTION	QTY
1	067048	WELD'T REAR ACCESS PLATFORM RIGHT	1
2	067050	WELD'T REAR ACCESS PLATFORM LEFT	1
3	067057	PLUG, 9283K34 F/ RAIL TUBES (AUS)	4
4	067060	DECK WELDMENT, 4' ACCESS PLATFORM (AUS)	1
5	067061	EXTENSION, INSIDE 4' ACCESS PLATFORM (AUS)	1
6	067063	TOP RAIL TUBE F/ 4' ACCESS PLATFORM (AUS)	1
7	067064	TUBE, MIDDLE RAIL F/ 4' ACCESS PLATFORM (AUS)	1
8	067065	KICK PLATE, INSIDE 4' ACCESS PLATFORM (AUS)	1
9	067066	KICK PLATE, OUTSIDE 4' ACCESS PLATFORM (AUS)	1
10	067079	WELDMENT F/ 4' OUTSIDE ACCESS PLATFORM EXTENSION (AUS)	1

SECTION 4 PARTS

2' Access Platform Assembly Illustration

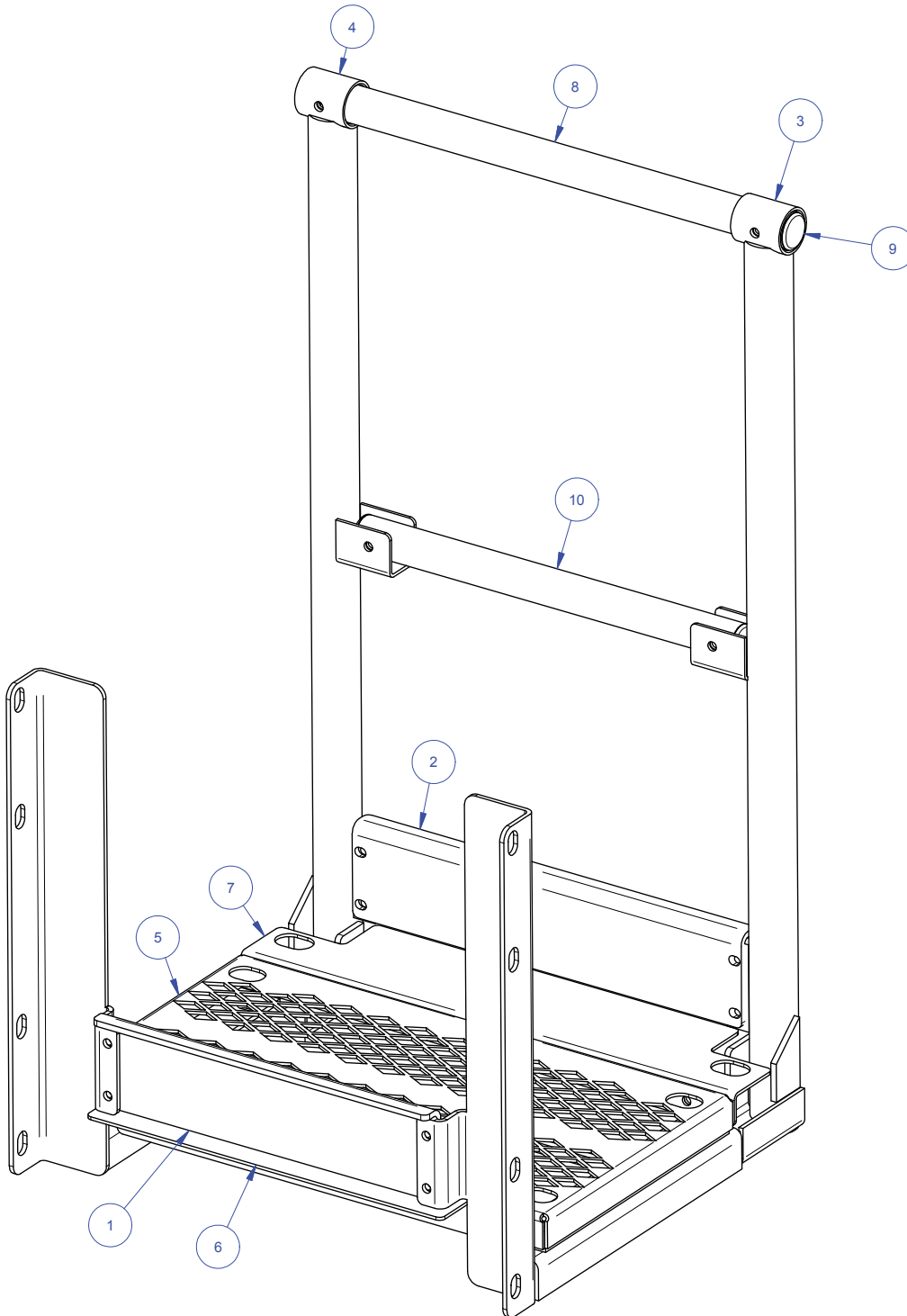

2' Access Platform Assembly Parts List

SECTION 4 PARTS

ITEM	PART NO.	DESCRIPTION	QTY
1	067036	KICK PLATE, INSIDE 2' ACCESS PLATFORM (AUS)	1
2	067038	KICK PLATE, OUTSIDE 2' ACCESS PLATFORM (AUS)	1
3	067048	WELD'T REAR ACCESS PLATFORM RIGHT	1
4	067050	WELD'T REAR ACCESS PLATFORM LEFT	1
5	067051	DECK WELDMENT, 2' ACCESS PLATFORM (AUS)	1
6	067054	EXTENSION, INSIDE 2' ACCESS PLATFORM (AUS)	1
7	067055	EXTENSION, OUTSIDE 2' ACCESS PLATFORM (AUS)	1
8	067056	TOP RAIL TUBE F/ 2' ACCESS PLATFORM (AUS)	1
9	067057	PLUG, 9283K34 F/ RAIL TUBES (AUS)	4
10	067058	TUBE, MIDDLE RAIL F/ 2' ACCESS PLATFORM (AUS)	1

**SECTION 4
PARTS**

**Vibrator Channel Bottom Covers
Illustration**

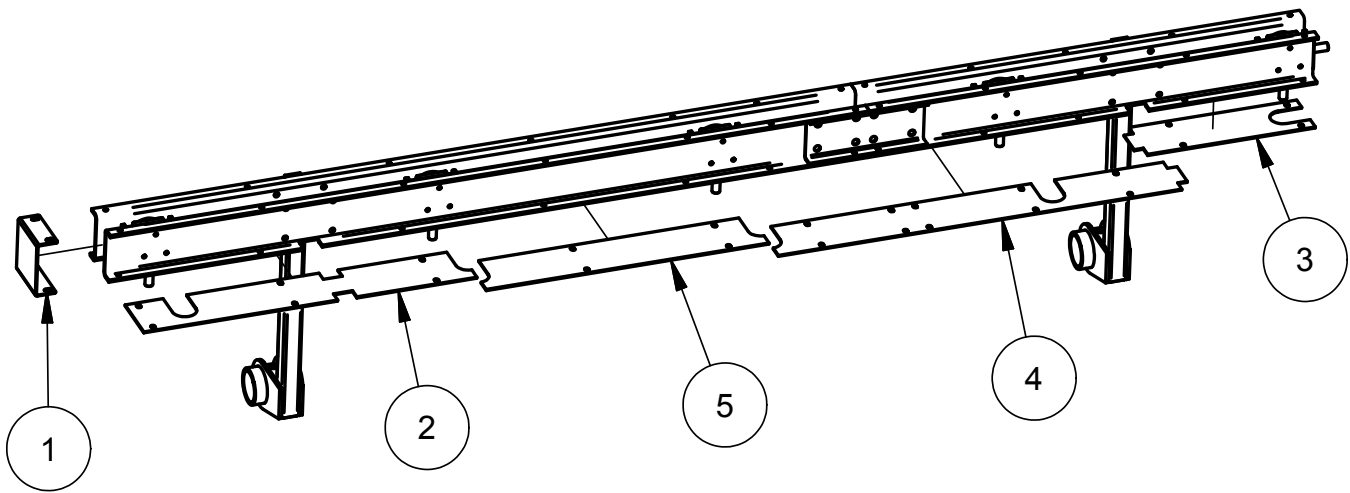

Vibrator Channel Bottom Covers Parts List

SECTION 4 PARTS

ITEM	PART NO.	DESCRIPTION	QTY
1	066895	COVER, END CAP FOR VIB DRIVE ASSEMBLY 255 TRTP GANG	1
2	066896	COVER, BOTTOM FOURTH FROM DRIVE END 5 BANK VIB DRIVE CHNL.	1
3	066897	COVER, BOTTOM FOR GANG TRTP 5 VIB BANK DRIVE CHANNEL FOR 255 TRTP	1
4	066898	COVER, BOTTOM SECOND FROM DRIVE END 5 BANK VIB DRIVE CHNL.	1
5	066899	COVER, BOTTOM THIRD FROM DRIVE END 5 BANK VIB DRIVE CHNL.	1

SECTION 4 PARTS

4.13 Illustration Spray Schematic

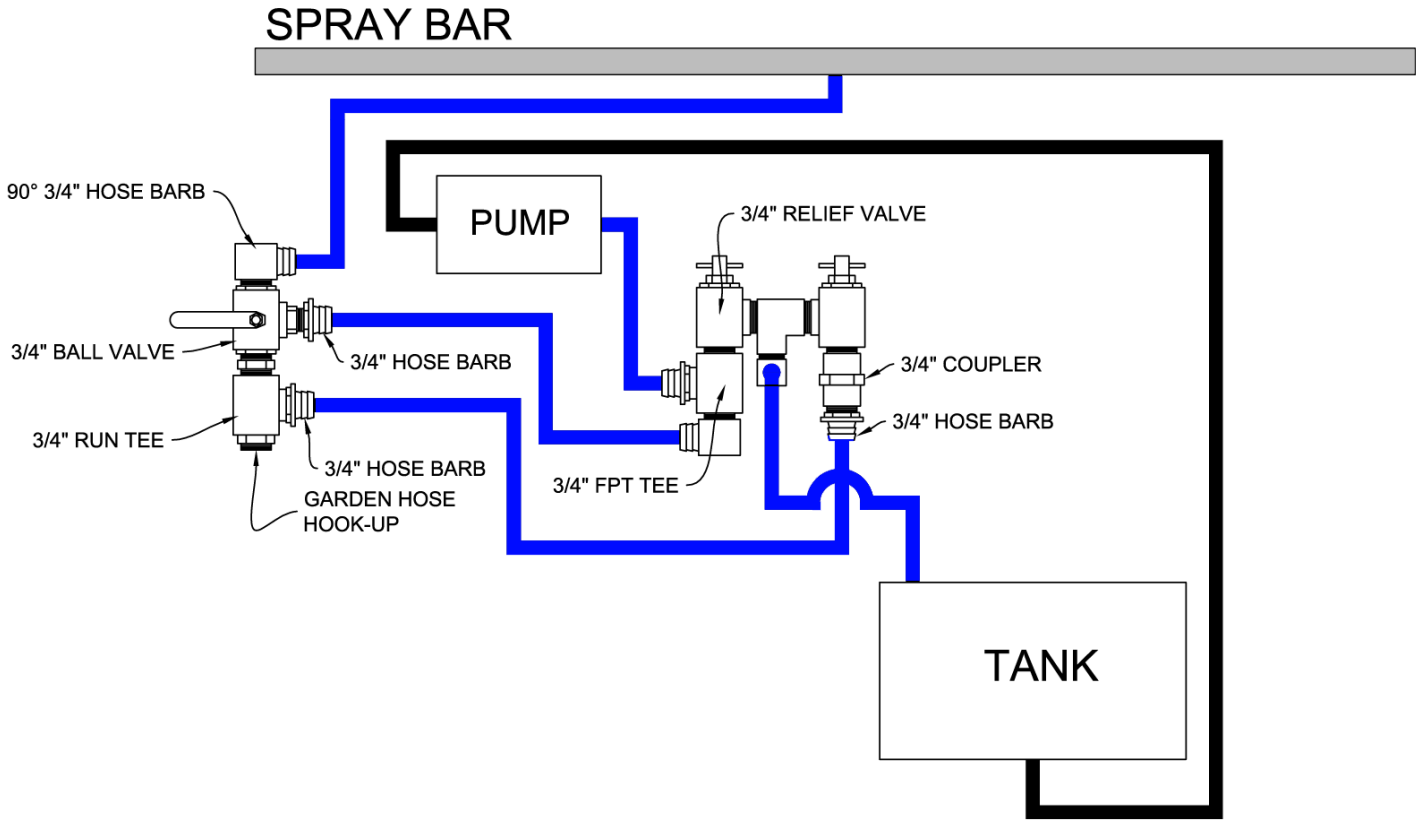

Section 5
VIBRATION

SECTION 5
VIBRATION

Vibration Table of Contents

Title Page.....5-1

Table of Contents5-2

Vibration Operations5-3

5.1Butterfly Assembly5-4 thru 5-5

5.2Vibrator Assembly5-6 thru 5-7

5.3Vibration Rack Assembly.....5-8

5.4Vibration Rack Matrix5-9

5.5Vibrator Shaft Assembly5-10 thru 5-11

5.6Motor End Assembly5-12 thru 5-13

5.7Idle End Assembly.....5-14 thru 5-15

5.8Gang Vibration Machine Parts5-16 thru 5-17

5.9Electrical Schematics5-18 thru 5-19

5.10Hydraulic Schematics.....5-20 thru 5-21



Vibration Operations

SECTION 5 VIBRATION

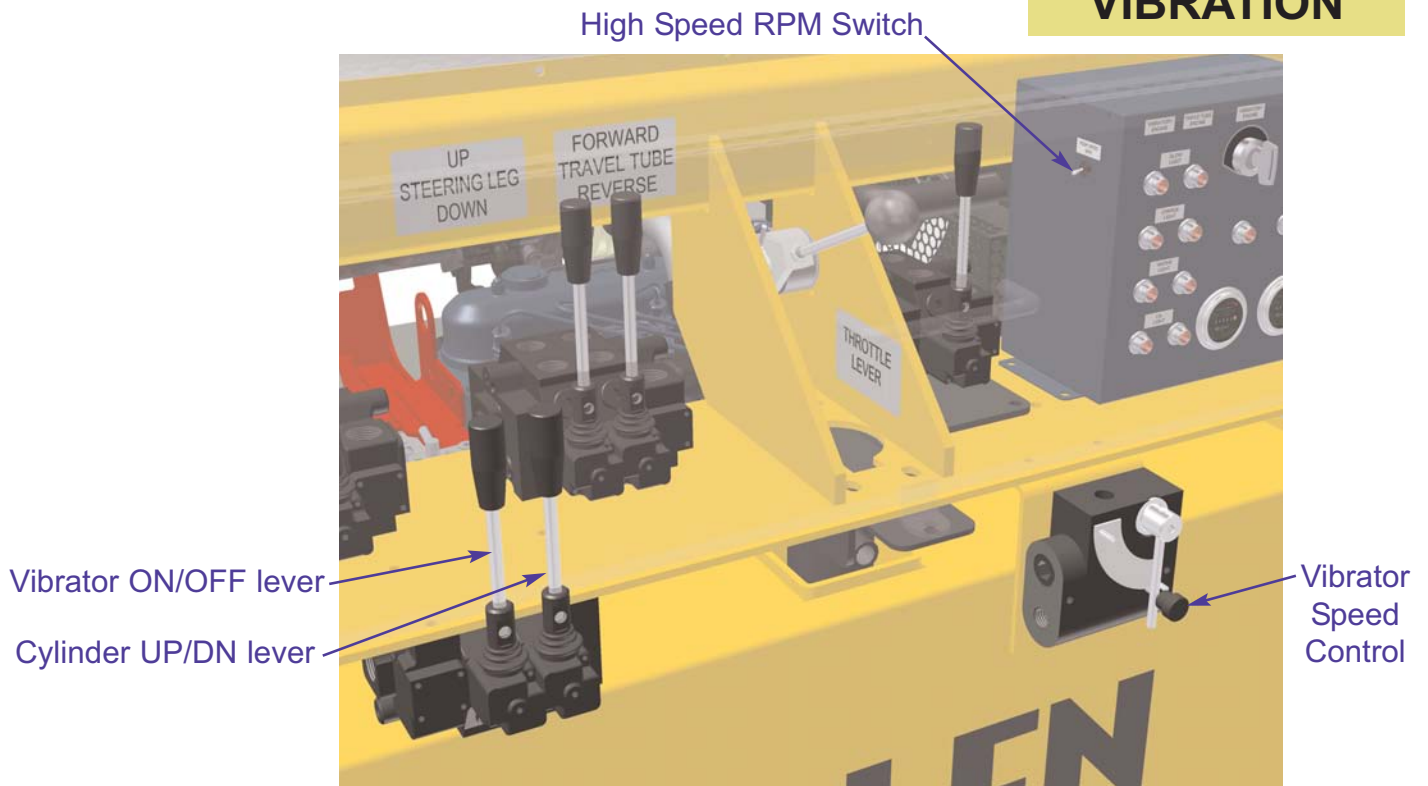

- 1) Start the engines normally as described on page 2-4.
- 2) Bring the operator engine to operating RPM.
- 3) Activate the switch on the side of the engine control box to bring the idle engine to operating RPM.
- 4) Turn the Vibrator ON/OFF lever to turn the vibrators “on” when entering concrete and “off” when exiting concrete. (Leaving the vibrators on out of concrete for more than 3 minutes can cause internal damage due to overheating.)
- 5) Use the Cylinder UP/DN lever to lower the vibrators into the concrete and raise them out.
- 6) Use the Vibrator Speed Control to control the amount of VPM's into the concrete.

Vibrator Technical Data

Model	Dia (mm)	Head Length (mm)	Freq (VPM)	Drive Size	Weight (kg)
VWU60	60	600	11,000	13 x 32	29

SECTION 5
VIBRATION

5.1 Illustration
Butterfly Assembly

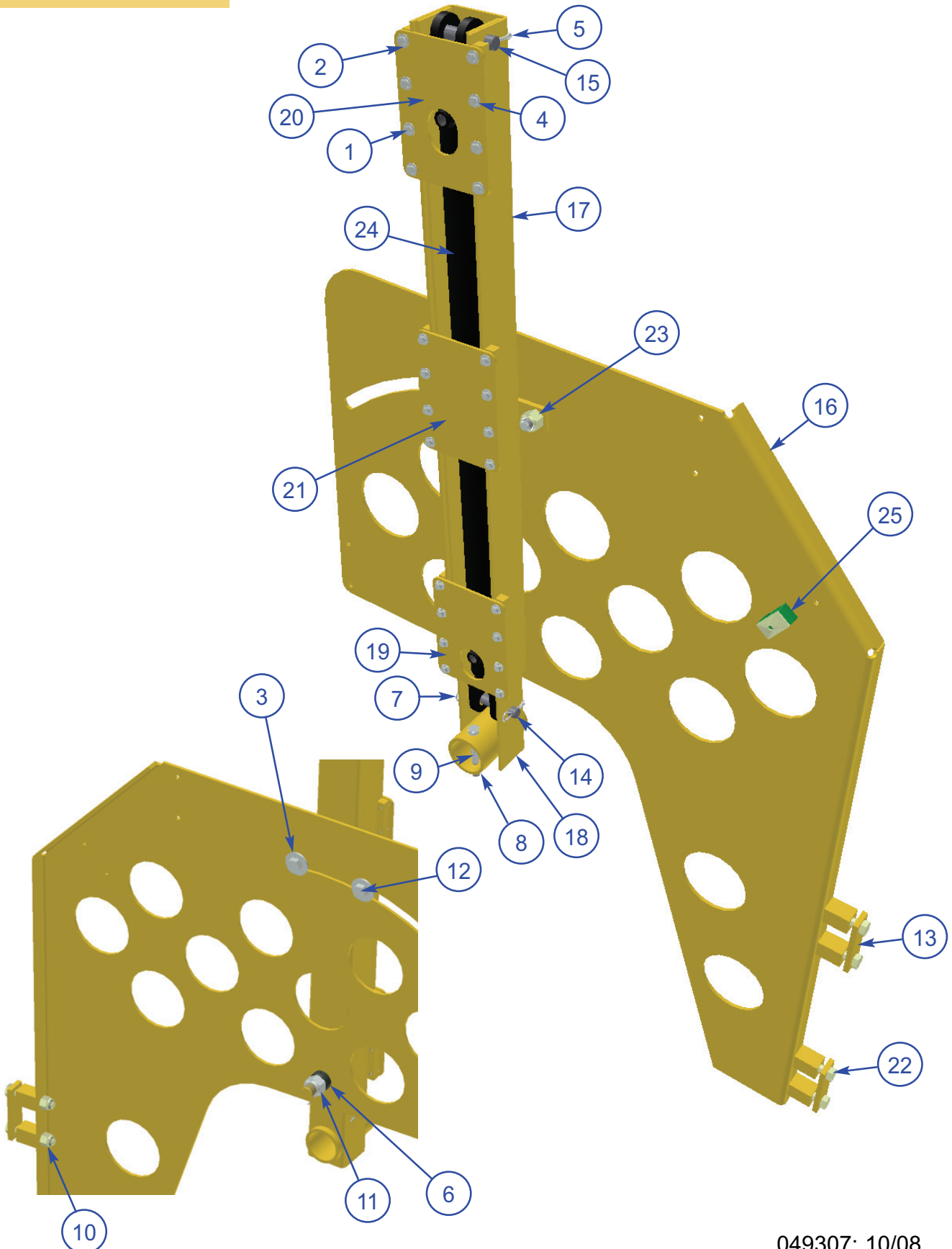

5.1 Parts List Butterfly Assembly

SECTION 5 VIBRATION

ITEM	PART #	DESCRIPTION	QTY
1	010003	FSTN, HHCS 1/4-20 X 1	24
2	010081	FSTN, FW 1/4	24
3	010087	FSTN, FW 3/4	2
4	010089	FSTN, LW 1/4	24
5	010133	PIN, Ø3/16 X 2 ZP STL COTTER	2
6	010666	COLLAR, Ø1 ID SET	1
7	010711	CLIP, .125x2-9/16 HITCH PIN	2
8	011238	FSTN, NUT HEX NYLOK 1/2-13	1
9	023003	FSTN, HHCS 1/2-13 X 4	1
10	037509	FSTN, NUT NYLOC 5/8-18 GR 8	4
11	038783	FSTN, NUT NYLOK 1"-8	1
12	040275	FSTN, HHCS 3/4-16 X 2 GR 8	2
13	048251	PLATE, CLAMP F/ GANG VIB MNT PLATE	2
14	048255	PIN, CYLINDER SHORT F/ GANG VIB	1
15	048256	PIN, CYLINDER LONG F/ GANG VIB	1
16	049243	BUTTERFLY, LH GANG VIB MOUNT	1
	049244	BUTTERFLY, RH GANG VIB MOUNT	1
17	049252	CHANNEL, OUTER HYD. CYL. WELD'T	1
18	049254	CHANNEL, MALE JACK WELD'T	1
19	049318	PLATE, TOP HOLDING HYD CYL	1
20	049319	PLATE, BOTTOM HOLDING HYD CYL	1
21	049320	PLATE, MIDDLE HOLDING HYD CYL	1
22	049346	FSTN, HHCS 5/8-11x3-3/4 GR 8	4
23	049351	FSTN, NUT 3/4-10 GR 8 NYLOCK HEX	2
24	049366	CYLINDER, LIFT F/ GANG RACK 255CD	1
25	049421	CLAMP, HOSE 5/8" HYD SP2D	1

SECTION 5
VIBRATION

5.2 Illustration
Vibrator Assembly

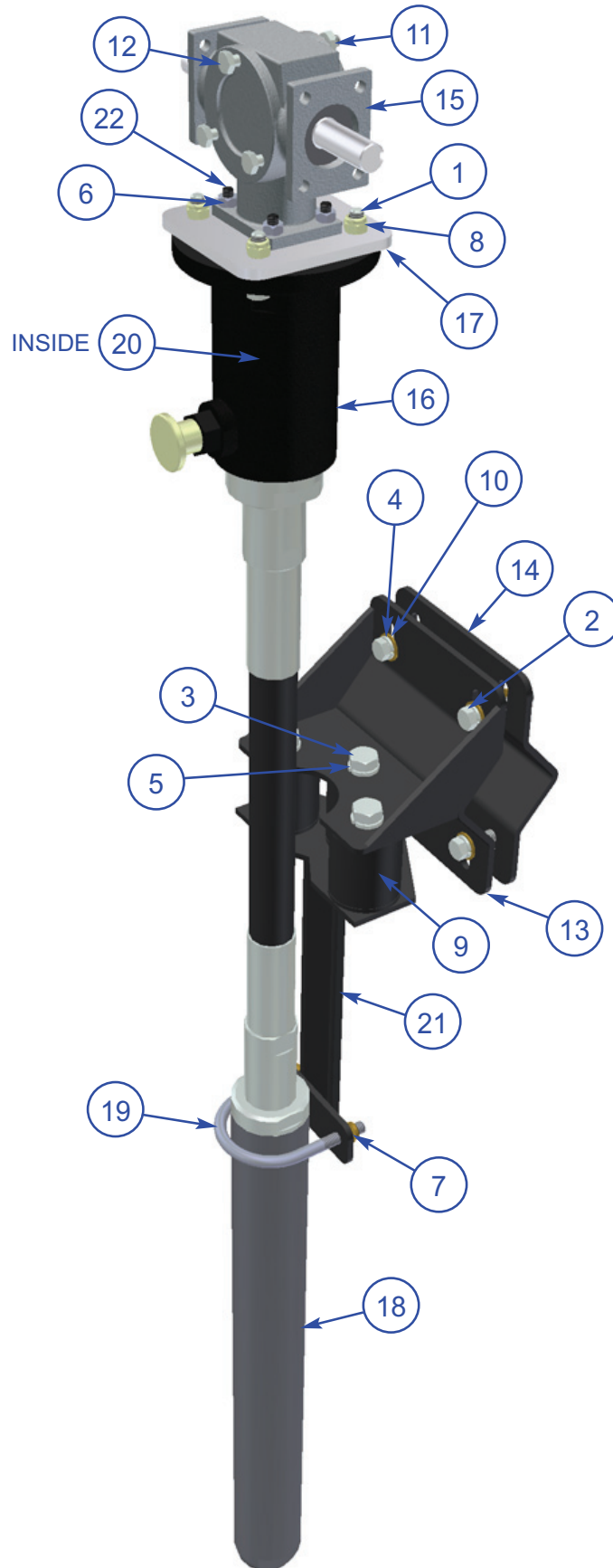

5.2 Parts List Vibrator Assembly

SECTION 5 VIBRATION

ITEM	PART #	DESCRIPTION	QTY
1	010021	FSTN, HHCS 5/16-18 X 1-1/4 GR5	4
2	010040	FSTN, HHCS 3/8-16 X 2 GR 5	4
3	010066	FSTN, HHCS 1/2-13 X 3/4 GR 5	6
4	010091	FSTN, LW 3/8	4
5	010093	FSTN, LW 1/2	6
6	010098	FSTN, NUT HEX 1/4-20	4
7	010464	FSTN, NUT NYLOK 3/8-16	6
8	012612	FSTN, NUT HEX NYLOCK 5/16-18	4
9	012725	ISOLATORS, RUBBER MOUNTS	3
10	017751	FSTN, FW HARD A325 3/8	8
11	020542	FSTN, NUT STOVER LOCK 1/4-20	3
12	033711	FSTN, HHCS 1/4-20 X 2 3/4	3
13	038735	GANG VIB TOP MFG BRKT	1
14	038738	CLAMP HALF F/ VIB MNT BRKT WELDMENT	1
15	044858	GEARBOX, AD5 F/ VIBRATORS	1
16	044861	POWER TAKE-OFF F/ VWU60 VIB (PT01)	1
17	044862	QUICK DISCONNECT ADAPTOR PLATE	1
18	044893	VIBRATOR, GANG VIB TRTP VWU60	1
19	045876	CLAMP, MUFFLER 2 1/2 EXHAUST	1
20	048345	COUPLER, DRIVE for VIBRATOR	1
21	049186	VIBRATOR SUPPORT BRACKET	1
22	049352	FSTN, 1/4-20x1 SKT FLT HD CAP SCR	4



SECTION 5
VIBRATION

5.3 Illustration
Vibration Rack Assembly

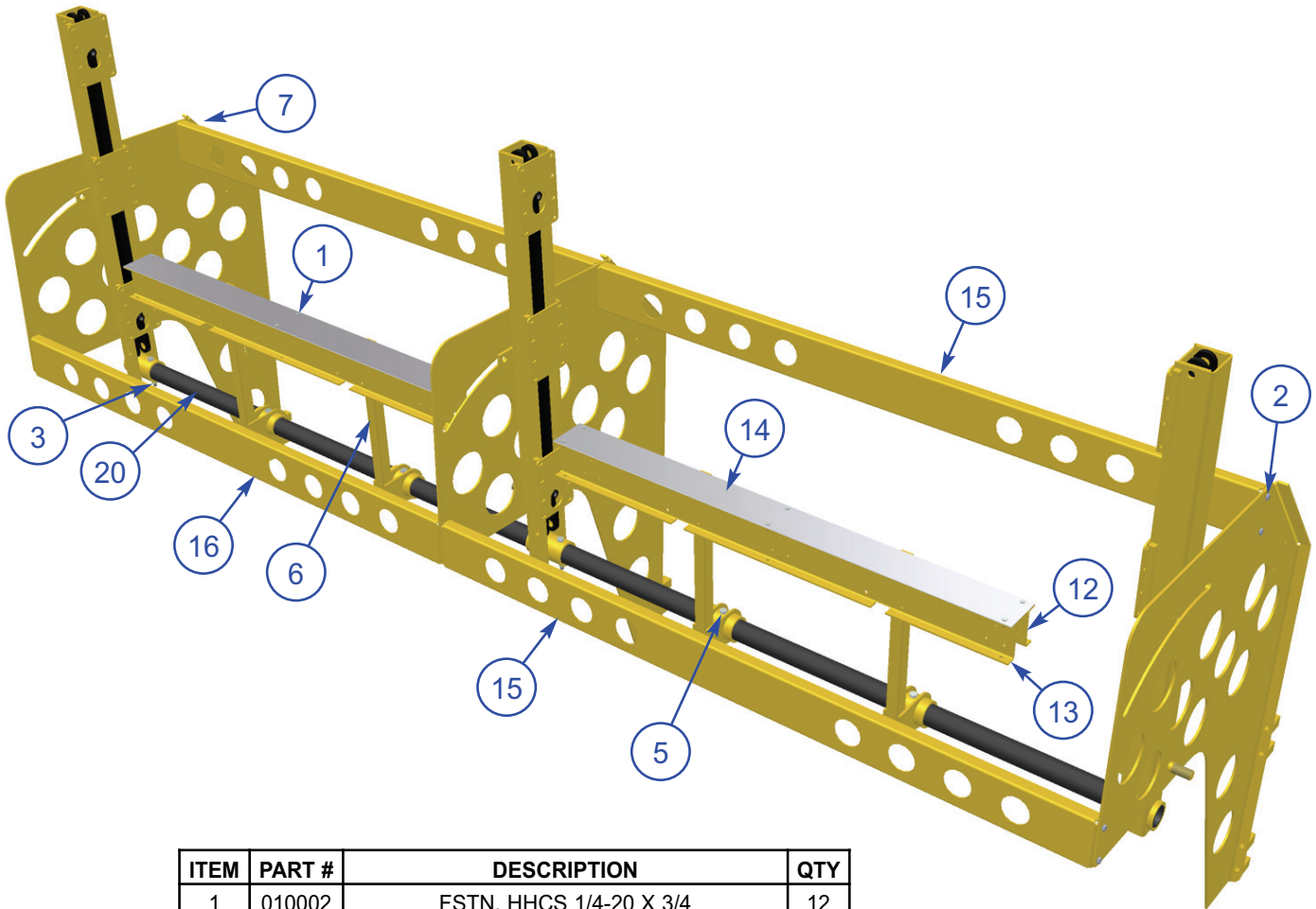

ITEM	PART #	DESCRIPTION	QTY
1	010002	FSTN, HHCS 1/4-20 X 3/4	12
2	010037	FSTN, HHCS 3/8-16 X 1-1/4 GR 5	28
3	011238	FSTN, NUT HEX NYLOK 1/2-13	19
4	020542	FSTN, NUT STOVER LOCK 1/4-20	15
5	023003	FSTN, HHCS 1/2-13 X 4	7
6	038772	WELD'T, GANG VIBRATOR MOUNT	4
7	046844	FSTN, 3/8-24 YEL-ZINC GR 8 HEX NUT	16
8	049243	BUTTERFLY, LH GANG VIB MOUNT	1
9	049244	BUTTERFLY, RH GANG VIB MOUNT	2
10	049252	CHANNEL, OUTER HYD. CYL. WELD'T	3
11	049254	CHANNEL, MALE JACK WELD'T	3
12	049279	PLATE, GEARBOX MOUNT RHF/LHR 14'	2
13	049280	PLATE, GEARBOX MOUNT RHR/LHF 14'	2
14	049281	PLATE, GEARBOX TOP COVER 14'	2
15	049282	CHANNEL, LH STIFFENER 14' SETUP	2
16	049283	CHANNEL, RH STIFFENER 14' SETUP	2
17	049318	PLATE, TOP HOLDING HYD CYL	3
18	049319	PLATE, BOTTOM HOLDING HYD CYL	3
19	049320	PLATE, MIDDLE HOLDING HYD CYL	3
20	049324	TUBE, 14' VIB RACK	1
21	049366	CYLINDER, LIFT F/ GANG RACK 255CD	3

5.4 Matrix Vibration Rack Assembly

SECTION 5 VIBRATION

	PART #	DESCRIPTION	QTY		PART #	DESCRIPTION	QTY
12'				26'			
	049432	COVER, 38" GEAR DRIVE F/ GANG	1		049433	COVER, 62" GEAR DRIVE F/ GANG	2
	049434	COVER, 64-1/4" GEAR DRIVE GANG	1		049434	COVER, 64-1/4" GEAR DRIVE GANG	2
	049441	WELD'T, 102-1/4" DRIVE MNT LHF/RHR	1		049435	WELD'T, 126 1/4" DRIVE MNT LHF/RHR	2
	049442	WELD'T, 102-1/4" DRIVE MNT LHR/RHF	1		049436	WELD'T, 126 1/4" DRIVE MNT LHR/RHF	2
	049447	STIFFENER, LH 126-5/8" GANG 255CD	2		049445	STIFFENER, RH 143-3/4" GANG 255CD	2
	049480	TUBE, 126 1/2" VIBRATOR RACK	1		049476	WELD'T, STIFFENER CHAN'L 150 5/8"LG	2
14'					049478	TUBE, 145 3/4" VIBRATOR RACK	1
12	051082	CHANNEL, VIBRATOR 14'	1		049479	TUBE, 148 1/2" VIBRATOR RACK	1
13	051082	CHANNEL, VIBRATOR 14'	1	28'			
14	051083	COVER, 14' VIB CHANNEL	2		049433	COVER, 62" GEAR DRIVE F/ GANG	1
15	051085	STIFFENER, 14' GANG VIB	1		049434	COVER, 64-1/4" GEAR DRIVE GANG	2
16	051085	STIFFENER, 14' GANG VIB	1		049435	WELD'T, 126 1/4" DRIVE MNT LHF/RHR	1
20	049324	TUBE, 14' VIB RACK	1		049436	WELD'T, 126 1/4" DRIVE MNT LHR/RHF	1
16'					049445	STIFFENER, RH 143-3/4" GANG 255CD	2
	049279	PLATE, GEARBOX MOUNT RHF/LHR 14'	1		049450	TUBE, 24' RH VIB RACK	1
	049280	PLATE, GEARBOX MOUNT RHR/LHF 14'	1		049458	WELD'T, STIFFENER CHAN'L 174 5/8"LG	2
	049283	CHANNEL, RH STIFFENER 14' SETUP	2		049460	COVER, 86" GEAR DRIVE F/ GANG	1
	049415	TUBE, 16' VIB RACK	1		049461	WELD'T, 150 1/4" DRIVE MNT LHR/RHF	1
	049468	78 1/4" GEAR MNT CHANL LHF/RHR	1		049462	WELD'T, 150 1/4" DRIVE MNT RHR/LHF	1
	049469	STIFFENER CHAN'L 102 5/8"LG	2		049465	TUBE, 172 1/2" VIBRATOR RACK	1
	049470	COVER, 78 1/4" GEAR DRIVE F/ GANG	1	30'			
18'					049432	COVER, 38" GEAR DRIVE F/ GANG	2
	049467	78 1/4" GEAR MNT CHANL LHR/RHF	2		049434	COVER, 64-1/4" GEAR DRIVE GANG	2
	049468	78 1/4" GEAR MNT CHANL LHF/RHR	2		049441	WELD'T, 102-1/4" DRIVE MNT LHF/RHR	2
	049469	STIFFENER CHAN'L 102 5/8"LG	2		049442	WELD'T, 102-1/4" DRIVE MNT LHR/RHF	2
	049470	COVER, 78 1/4" GEAR DRIVE F/ GANG	2		049454	WELD'T, STIFFENER CHAN'L 119 3/4"LG	2
	049471	STIFFENER CHAN'L 95 3/4" LG	2		049455	WELD'T, STIFFENER CHAN'L 126 1/4"LG	2
	049472	TUBE, 198 1/2" VIBRATOR RACK	1		049467	78 1/4" GEAR MNT CHANL LHR/RHF	1
20'					049468	78 1/4" GEAR MNT CHANL LHF/RHR	1
	049432	COVER, 38" GEAR DRIVE F/ GANG	2		049470	COVER, 78 1/4" GEAR DRIVE F/ GANG	1
	049434	COVER, 64-1/4" GEAR DRIVE GANG	1		049471	STIFFENER CHAN'L 95 3/4" LG	2
	049441	WELD'T, 102-1/4" DRIVE MNT LHF/RHR	2		049482	TUBE, 121 3/4" VIBRATOR RACK	1
	049442	WELD'T, 102-1/4" DRIVE MNT LHR/RHF	1		049483	TUBE, 122 1/2" VIBRATOR RACK	1
	049454	WELD'T, STIFFENER CHAN'L 119 3/4"LG	1		049484	TUBE, 97 1/2" VIBRATOR RACK	1
	049467	78 1/4" GEAR MNT CHANL LHR/RHF	1	32'			
	049468	78 1/4" GEAR MNT CHANL LHF/RHR	1		049432	COVER, 38" GEAR DRIVE F/ GANG	3
	049469	STIFFENER CHAN'L 102 5/8"LG	1		049434	COVER, 64-1/4" GEAR DRIVE GANG	3
	049470	COVER, 78 1/4" GEAR DRIVE F/ GANG	1		049441	WELD'T, 102-1/4" DRIVE MNT LHF/RHR	3
	049481	TUBE, 222 1/2" VIBRATOR RACK	1		049442	WELD'T, 102-1/4" DRIVE MNT LHR/RHF	3
22'					049452	TUBE, 121 3/4" VIBRATOR RACK	2
	049432	COVER, 38" GEAR DRIVE F/ GANG	2		049453	TUBE, 122 1/2" VIBRATOR RACK	1
	049434	COVER, 64-1/4" GEAR DRIVE GANG	2		049454	WELD'T, STIFFENER CHAN'L 119 3/4"LG	4
	049441	WELD'T, 102-1/4" DRIVE MNT LHF/RHR	2		049455	WELD'T, STIFFENER CHAN'L 126 1/4"LG	2
	049442	WELD'T, 102-1/4" DRIVE MNT LHR/RHF	2	34'			
	049447	STIFFENER, LH 126-5/8" GANG 255CD	2		049432	COVER, 38" GEAR DRIVE F/ GANG	2
	049454	WELD'T, STIFFENER CHAN'L 119 3/4"LG	2		049433	COVER, 64-1/4" GEAR DRIVE GANG	1
	049474	TUBE, 124 1/2" VIBRATOR RACK	1		049434	COVER, 64-1/4" GEAR DRIVE GANG	3
	049475	TUBE, 121 3/4" VIBRATOR RACK	1		049435	WELD'T, 126 1/4" DRIVE MNT LHF/RHR	1
24'					049436	WELD'T, 126 1/4" DRIVE MNT LHR/RHF	1
	049433	COVER, 62" GEAR DRIVE F/ GANG	1		049441	WELD'T, 102-1/4" DRIVE MNT LHF/RHR	2
	049434	COVER, 64-1/4" GEAR DRIVE GANG	2		049442	WELD'T, 102-1/4" DRIVE MNT LHR/RHF	2
	049435	WELD'T, 126 1/4" DRIVE MNT LHF/RHR	1		049445	STIFFENER, RH 143-3/4" GANG 255CD	2
	049436	WELD'T, 126 1/4" DRIVE MNT LHR/RHF	1		049447	STIFFENER, LH 126-5/8" GANG 255CD	2
	049441	WELD'T, 102-1/4" DRIVE MNT LHF/RHR	1		049450	TUBE, 24' RH VIB RACK	1
	049442	WELD'T, 102-1/4" DRIVE MNT LHR/RHF	1		049452	TUBE, 121 3/4" VIBRATOR RACK	1
	049445	STIFFENER, RH 143-3/4" GANG 255CD	2		049453	TUBE, 122 1/2" VIBRATOR RACK	1
	049447	STIFFENER, LH 126-5/8" GANG 255CD	2		049454	WELD'T, STIFFENER CHAN'L 119 3/4"LG	2
	049450	TUBE, 24' RH VIB RACK	1				
	049451	TUBE, 24' LH VIB RACK	1				

SECTION 5
VIBRATION

5.5 Illustration
Vibrator Shaft Assembly

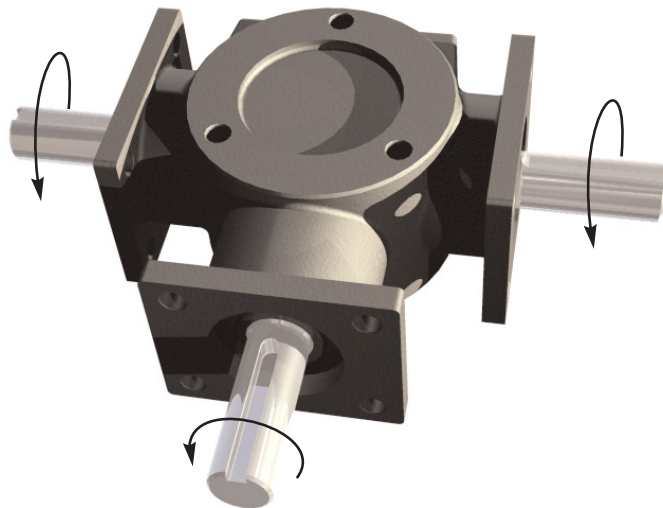
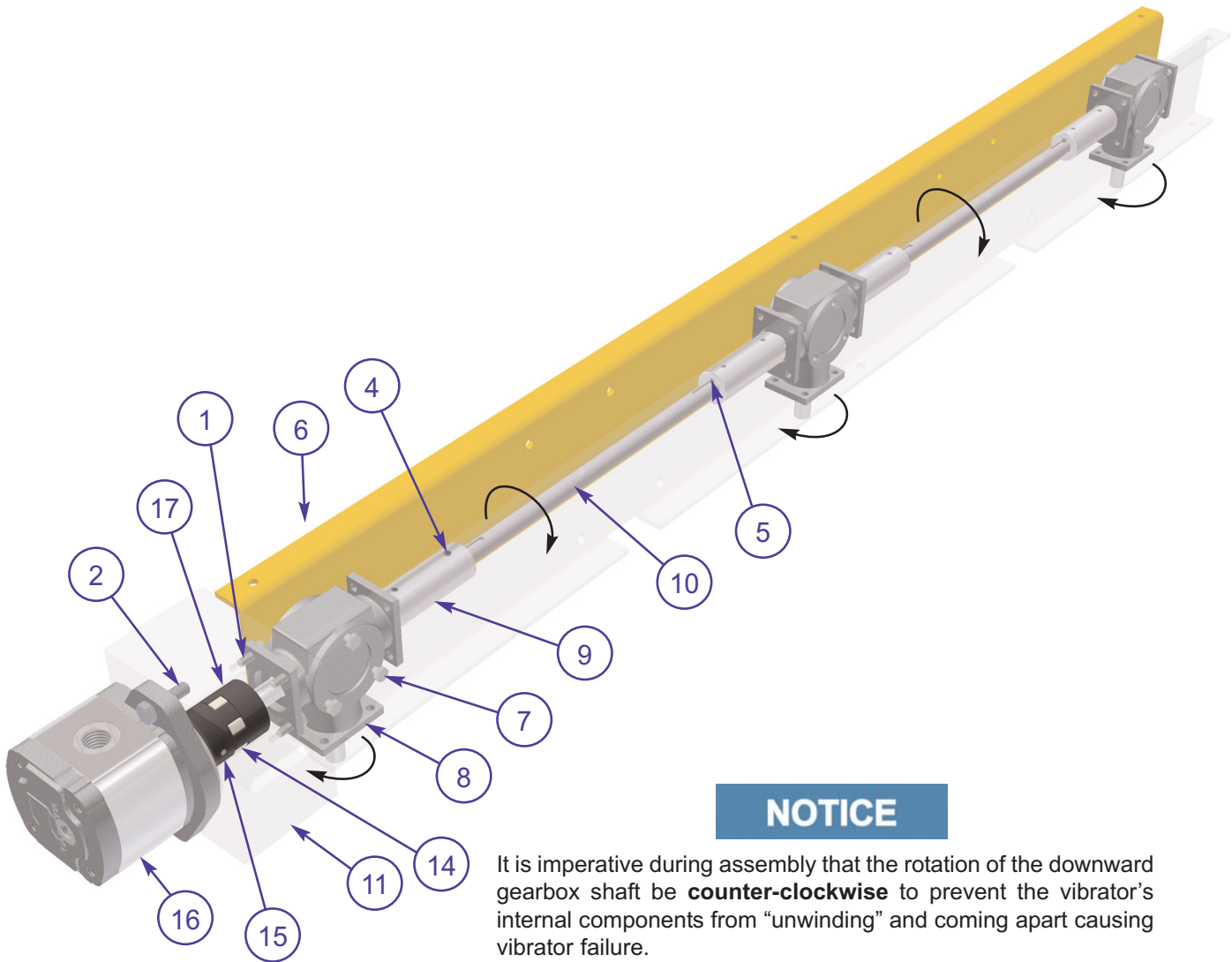

5.5 Parts List Vibrator Shaft Assembly

SECTION 5 VIBRATION

ITEM	PART #	DESCRIPTION	QTY
1	049959	STUD, ADAPTER BLOCK MOUNT	4
2	010037	FSTN, HHCS 3/8-16 X 1-1/4 GR 5	2
3	010089	FSTN, LW 1/4	4
4	012869	FSTN, SHSS 1/4-20 X 3/8	4
5	015813	KEY, 3/16" SQ X 1" LG	8
6	020542	FSTN, NUT STOVER LOCK 1/4-20	3
7	033711	FSTN, HHCS 1/4-20 X 2 3/4	3
8	044858	GEARBOX, AD5 F/ VIBRATORS	3
9	044859	COUPLER, DRIVE SHAFT F/ VIB RACK	4
10	044860	SHAFT, 15 1/2" DRIVE	2
11	044889	ADAPTOR BLOCK F/ GEARBOX DRIVE	1
12	049279	PLATE, GEARBOX MOUNT RHF/LHR 14'	1
13	049280	PLATE, GEARBOX MOUNT RHR/LHF 14'	1
14	049327	SPIDER, LOVEJOY HYD MOTOR (L-075)	1
15	049345	COUPLER, JAW (685144-37240)	1
16	049367	MOTOR, HYD F/ GANG VIB 255CD	1
17	049416	COUPLER, JAW (685144-10688)	1



SECTION 5
VIBRATION

5.6 Illustration
Motor End Assembly



See page 4-6 for complete motor end component breakdown. This illustration only shows only items that pertain to the vibration system.



5.6 Parts List Motor End Assembly

SECTION 5 VIBRATION

ITEM	PART #	DESCRIPTION	QTY
1	048203	PLATE, FLOW CONTROL MOUNT	1
2	049407	PANEL, GANG VIBRATION CONTROL	1
3	049368	FLOW CONTROL, ADJ F/ GANG VIB 255CD	1
4	049369	VALVE STACK, 2-STATION PILOT CONTROL	1



SECTION 5
VIBRATION

5.7 Illustration
Idle End Assembly

NOTE

See hydraulic schematic Page 5-21 for hydraulic component parts list.

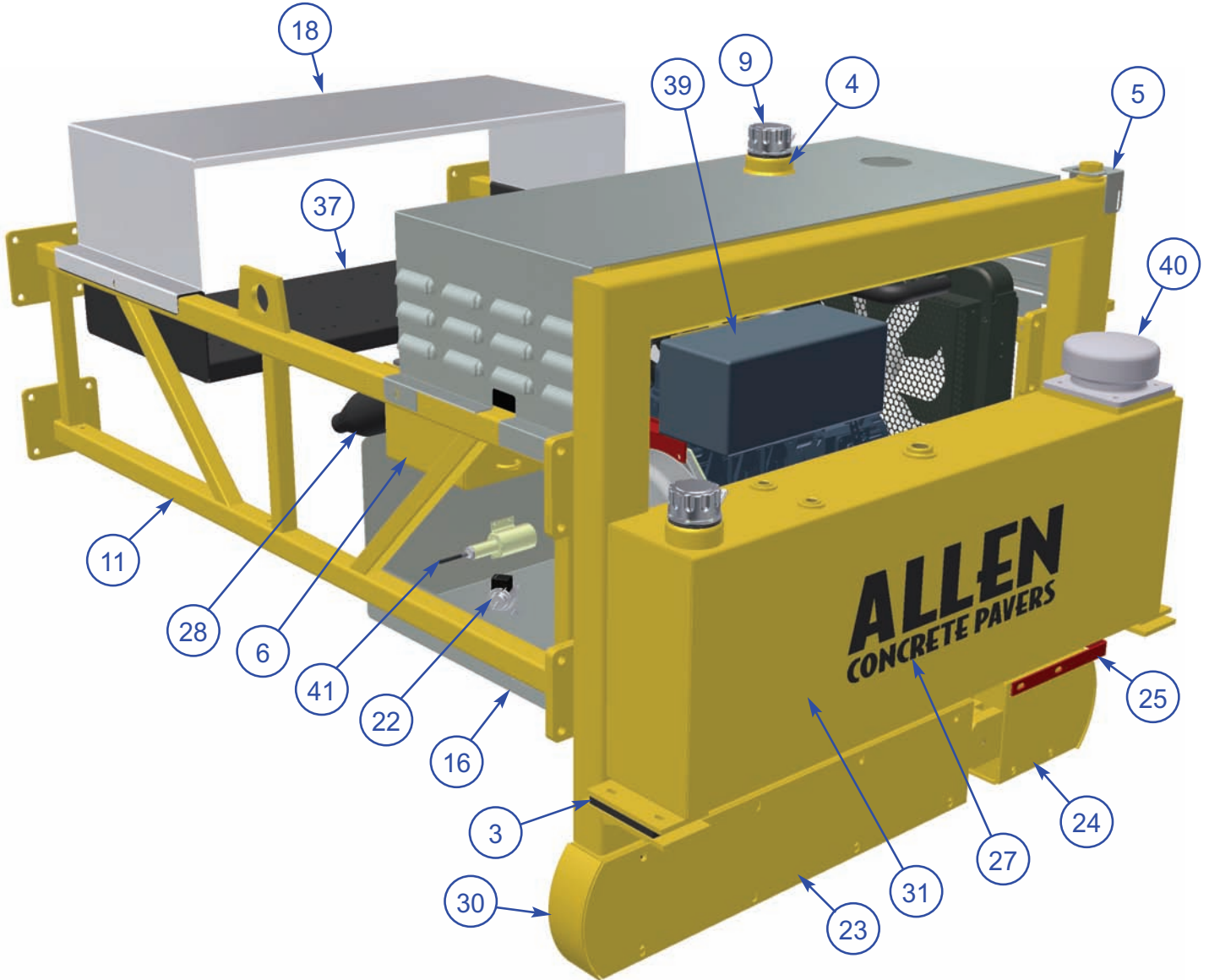

5.7 Parts List Idle End Assembly

SECTION 5 VIBRATION

ITEM	PART #	DESCRIPTION	QTY
1	012725	ISOLATORS, RUBBER MOUNTS	4
2	029059	BUSHING, FUEL TANK TRTF	2
3	029098	BUSHING, F/HYD TANK TRTF	2
4	029127	TANK, FUEL	1
5	029136	LOCK, F/ END HANDLE TRTF	1
6	029213	BOX, BATTERY TRTF	1
7	029222	BEARING IDLE END 1 1/4 TRTF	3
8	029245	BRACKET, ENGINE TRTF	4
9	032268	UNIT, CHROME GAS-HYDR TANK CAP	2
10	032273	DECAL, VERTICAL ADJ. TRTP	1
11	037577	FRAME, TRTP 6' END	2
12	037647	END EXTENSION F/SPRAY BAR BRKT	2
13	037771	BATTERY, 12 V GRAY 655CA	1
14	037791	TANK, OVERFLOW W/ BRACKET	1
16	038582	PAN, MOD 255 BD ENGINE	1
17	038583	COVER, MOD 255BD ENGINE	1
18	038799	COVER, GANG VIB CONTROL	1
19	038882	CUSHION,BATT.BOX REAR F/TRTF	1
20	038914L	BRACKET, SPRAY SYSTEM LH - 255	1
21	038914R	BRACKET, SPRAY SYSTEM RH - 255	1
22	040330	PUMP, 12 V ELECTRONIC FUEL	1
23	042005	COVER, BASE FORWARD IDLE END (LARGE)	1
24	042006	COVER, BASE FORWARD IDLE END (SMALL)	1
25	042942	WELD'T POINTER IDLE END 255 TRTP	1
26	043057	GAUGE, SNA HYDR LEVEL	1
27	043200	DECAL, ACP BLACK 7.5 X 22	1
28	043288	MUFFLER, 44KB TURBO C52	1
29	043291C	ENGINE, KUBOTA 44 TURBO V1505TE3BB-1	1
30	044775	END HANDLE, GANG VIB TRTP IDLE END	1
31	044777	TANK, GANG VIB TRTP HYDRAULIC	1
32	046375	WELDMENT, MUFFLER MOUNT BRKT	1
33	046379	WELDMENT, TAIL PIPE	1
34	046394	COVER, ALTERNATOR	1
35	046688	HOUSING, HD530A 952057 COUPLER	1
36	047172	GAUGE, 3" SITE LEVEL	1
37	048218	VALVE MOUNT, SPLITTER/ROTORY GANG	1
38	048658	PUMP, AUXILLARY X1	1
39	049353	PANEL, GANG VIBRATION ENGINE RELAY	1
40	049355	FILTER, IKRON F/ GANG VIB 255CD	1
41	049406	KIT, THROTTLE (P613-K1V12)	1

SECTION 5
VIBRATION

5.8 Illustration
Gang Vibration Parts

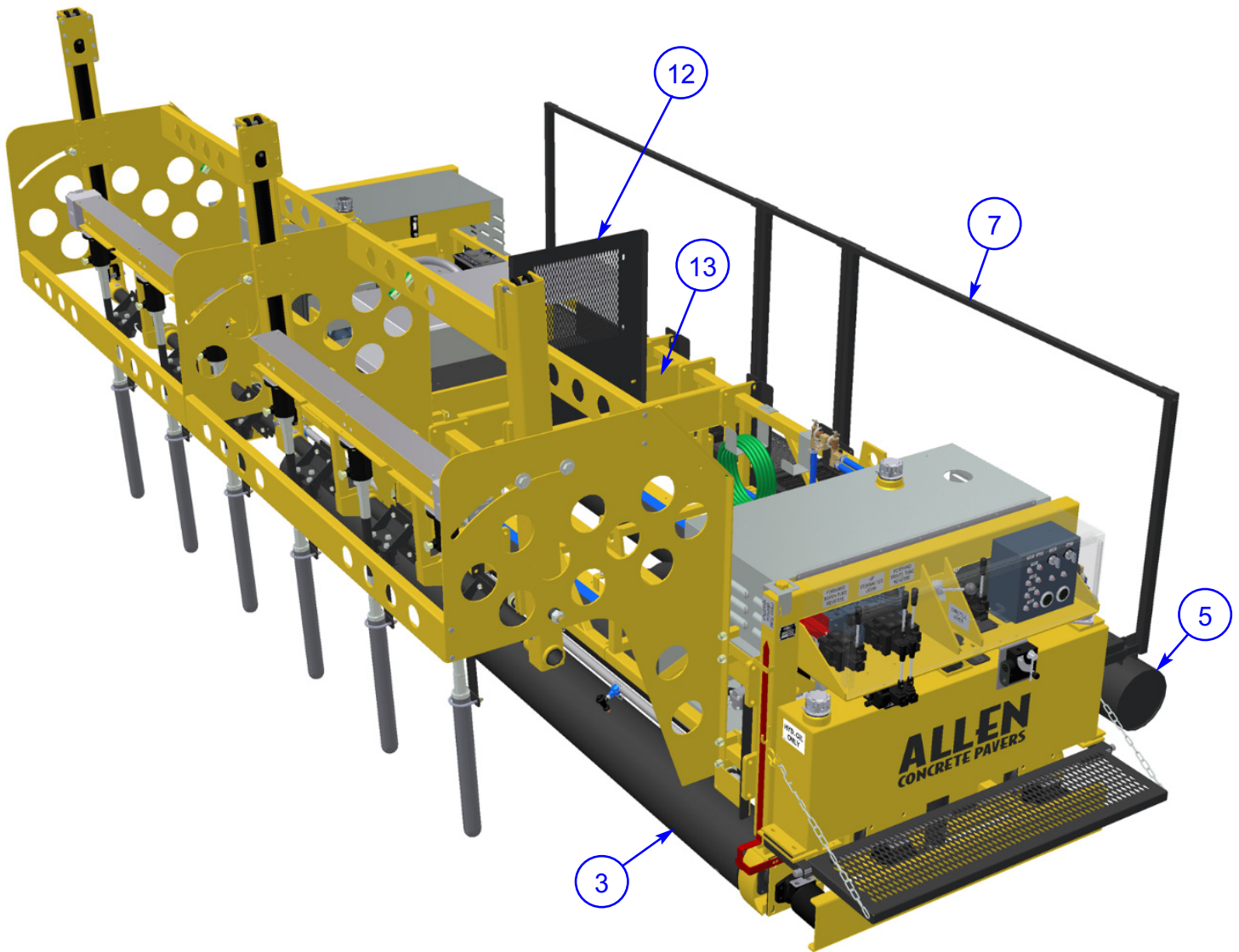

NOTE:

It is not uncommon for a pendulum-type vibrator head to fail to vibrate when the motor is switched on or started. If the vibrating head does not commence vibrating immediately, **tap the tip of the vibrator head sharply with a rubber mallet.**

5.8 Parts List Gang Vibration Parts

SECTION 5 VIBRATION

ITEM	PART #	DESCRIPTION	QTY
1	027883	BUSHING, RUBBER SPLIT	4
2	027884	CLAMP, LOPRO ENGINE MOUNT	8
3	028319-NL	TUBE, TRTF 10"	3
4	029205	BRACKET, STIFFENER TRTF	2
5	034003-NL	BALLAST, WATER TUBE	1
6	037569-18	FRAME, TRTP 1' SPACER	4
7	037597-NL	WALKWAY, REAR 200B/200BD	1
8	038914L	BRACKET, SPRAY SYSTEM LH - 255	1
9	040108	FTG, 3/4 MPT x 3/4 HOSE BARB	1
10	041611	ASSY, SPRAY BAR (6' END)	1
11	042035-NL	ASSY, 255BD TRTP SCRAPER	1
12	049192	COOLER, MOUNT BRACKET	1
13	049326	STIFFENER, FRAME W/ COOLER MNT HOLES	1



SECTION 5 VIBRATION

5.9 Schematic Motor Electrical Schematics

OPERATOR END ENGINE ELECTRICAL SCHEMATIC

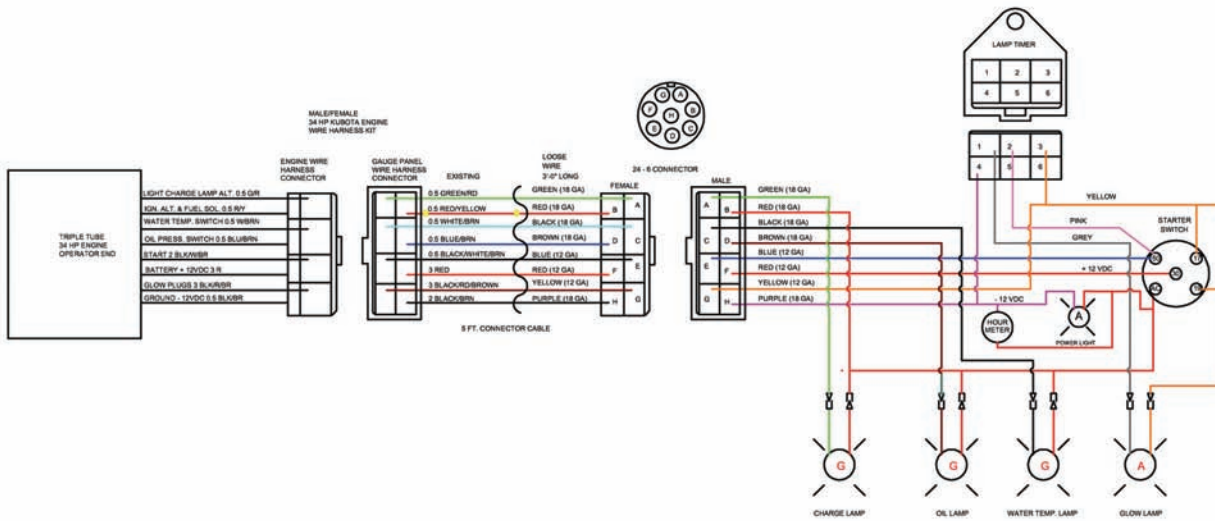

VIBRATORY END ENGINE ELECTRICAL SCHEMATIC

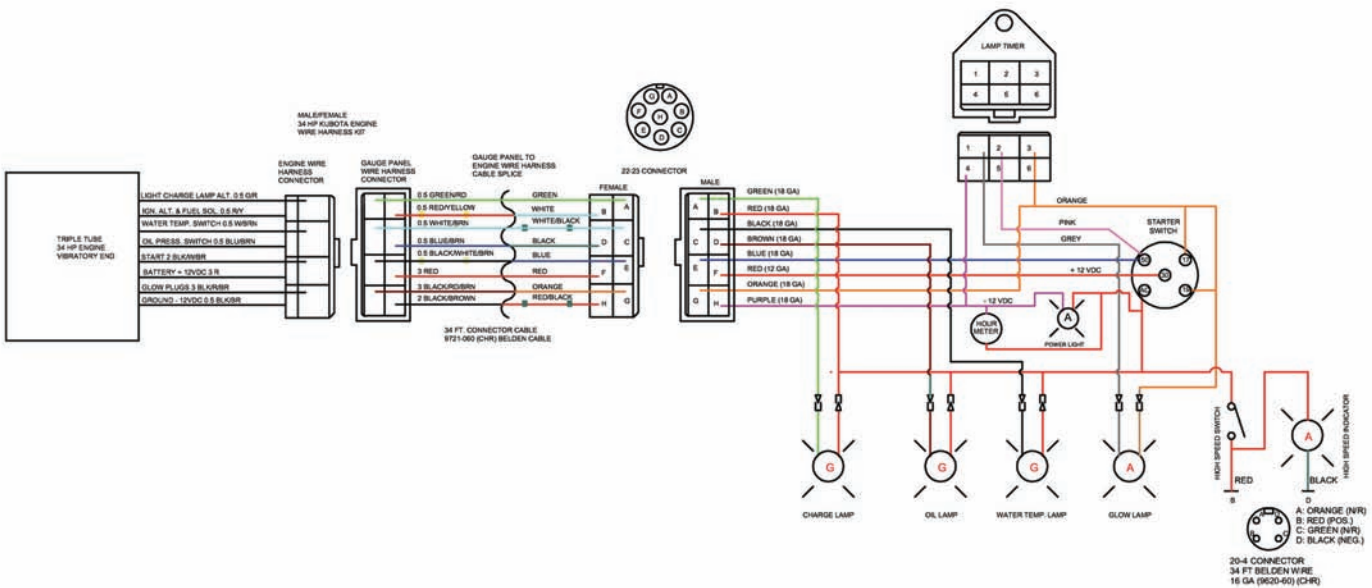

5.9 Schematic Machine Electrical Schematic

SECTION 5 VIBRATION

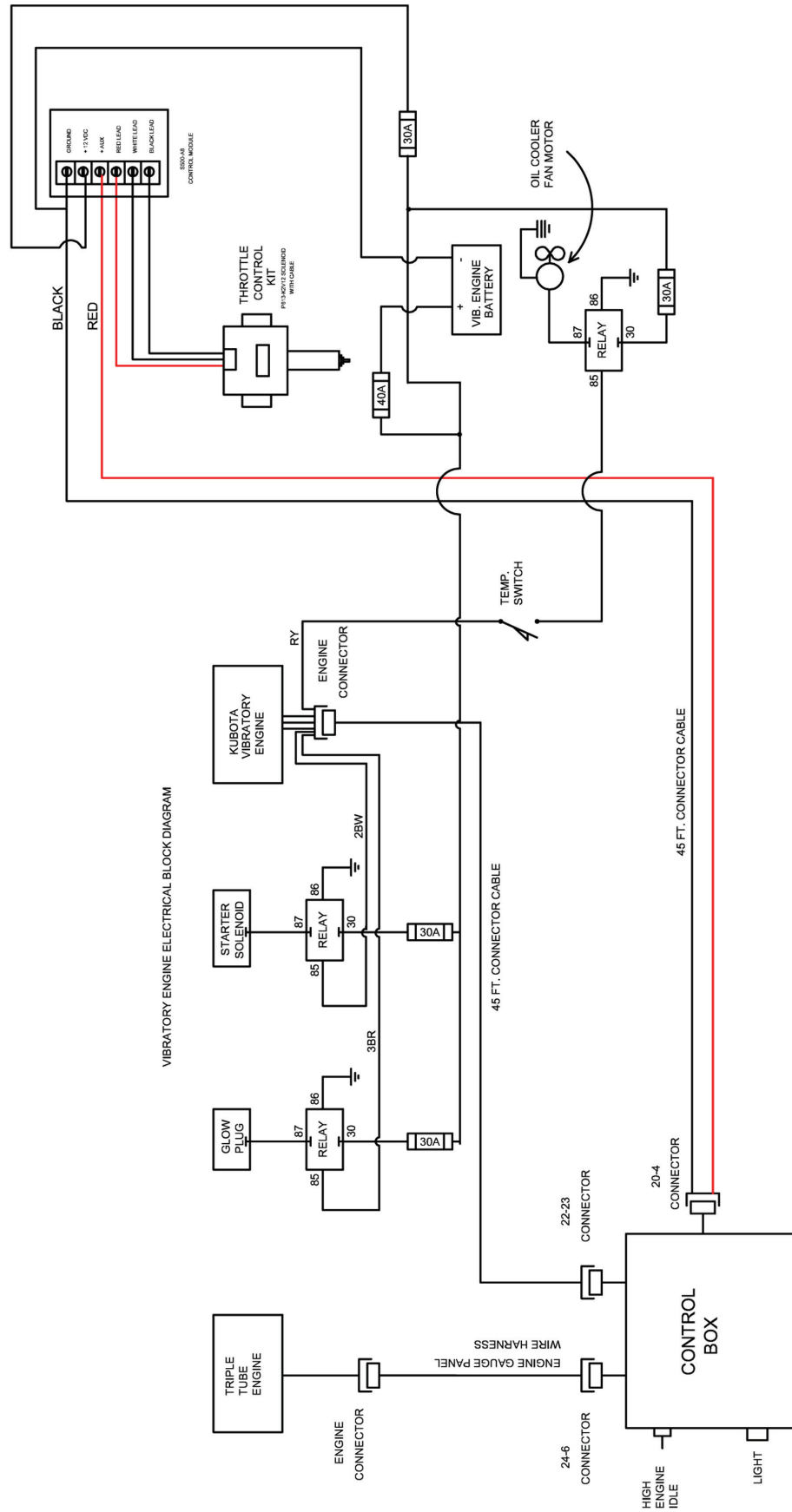

SECTION 5 VIBRATION

5.10 Schematic Vibration Hydraulic Schematic

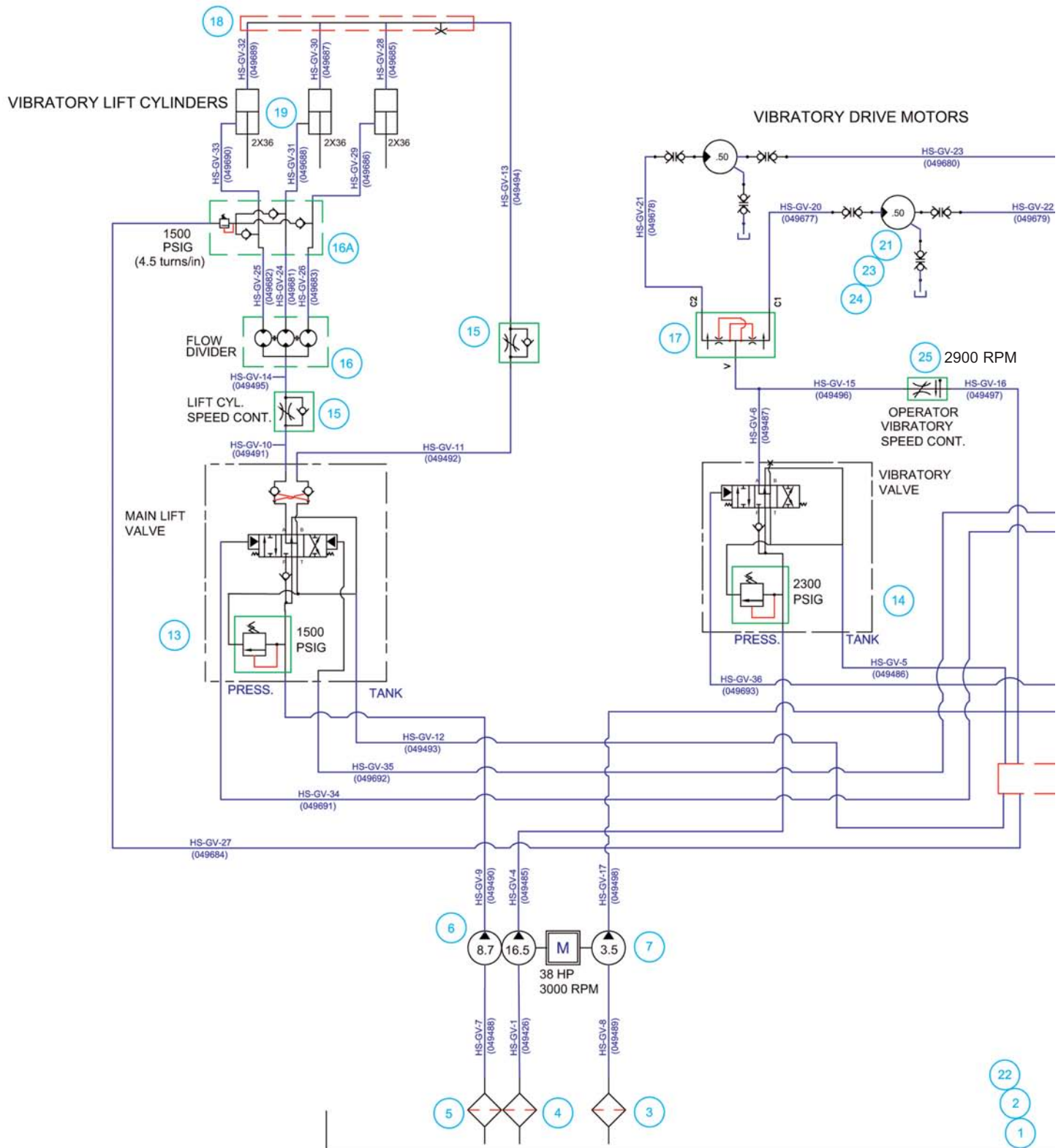

5.10 Schematic Vibration Hydraulic Schematic

SECTION 5 VIBRATION

ITEM	PART #	DESCRIPTION	QTY
1	042844	SNA127BSTU SITE LEVEL GAUGE	1
2	032268	SMBB-80S-L-40-0-B-S080-0 FILLER/BREATHER ASSY.	2
3	040072	TMF-05-5 SUCTION STRAINER	1
4	049357	TMF-25-5 SUCTION STRAINER	1
5	040073	TMF-10-5 SUCTION STRAINER	2
6	049354	PLP-20-20-04S5-LOD/OC/20-11,2-L/OC/D-N-EL TANDEM PUMP	1
7	048658	PLP10.4S0-C9W7-POB/OA-N-EL PILOT CONTROL PUMP	1
8	049355	HF550-30.162-AS-FG010-B17-(#16 SAE)-6B-H-Z-XA/XB-(1/8" NPT)-G-YN TANK FILTER	1
9	046241	CL-20 DIRTY FILTER GAUGE	1
10	049356	DC-20-12-VDC AIR/OIL COOLER	1
11	049102	SP.1068 TEMPERATURE SWITCH ASSY.	1
12	049358	AH0900412S TANK RETURN HEADER	1
13	049359	SD5/1-P(KG3-120)/281B3/BP3/AET-SAE LIFT CYLINDER CONTROL VALVE	1
14	049360	SD18/1-P(KG3-120)/281B2/AET-SAE VIBRATORY MOTOR CONTROL VALVE	1
15	049089	NDRV12 FLOW CONTROL VALVES	2
16	049361	950900M8699AAAAA THREE SECTION FLOW DIVIDER	1
16A	049362	SP.1274 FLOW DIVIDER RELIEVING MANIFOLD	1
17	049466	SP.1382 FLOW COMBINER / FLOW DIVIDER	1
18	049365	AH0000308S HEADER BLOCK	1
19	049366	661325 VIBRATORY HYDRAULIC CYLINDERS	3
21	049367	PLM20-8R0-31S1-L/OC/OC-N-EL VIBRATORY MOTORS	2
22	047172	SNA-076-B-S-O-U DIESEL TANK SITE GLASS	1
23	040070	SP2D-217/1/171DPP-GDAS 3/8" HOSE BRACKET ASSEMBLY	3
24	040071	SP3D-3200/200DPP-GDAS 1/2" HOSE BRACKET ASSEMBLY	2
25	049368	FC-51-1/2" VIBRATORY BYPASS FLOW CONTROL	1
26	049369	SD5/2-P(KG3-500)/28U/29U/AE-SAE TWO STATION PILOT CONTROL VALVE STACK	1
27	040064	AL01/M&X150 CONTROL HANDLES	2

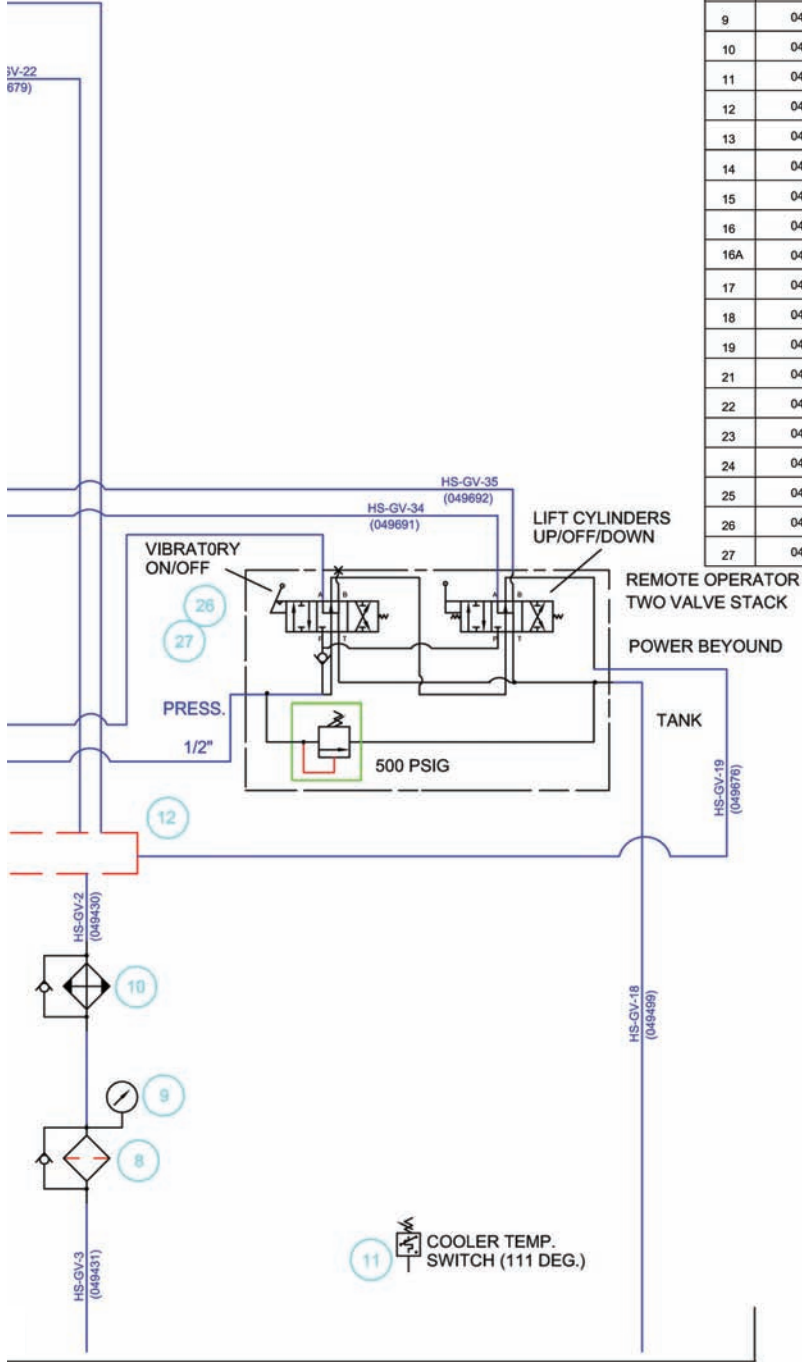

Section 6
HATZ DIESEL

SECTION 6 HATZ

Hatz Diesel Specifications

Technical data		4H50TIC .DPF	4H50TIC	4H50TI
Type	Water-cooled 4-cylinder turbo engine with BOSCH common rail OHW, 1800 bar, charge air cooling			
Exhaust emission after-treatment	EGR, DOC, DPF	EGR, DOC	—	
Bore x stroke (mm / inches)	84 x 88 / 3.31 x 3.46			
Displacement (l / cu.in.)	1.952 / 119.12			
Mean piston speed at 3000 rpm (m/s / ft/min)	8.8 / 1.732			
Engine	Compression ratio	17,5:1		
	Lub. oil consumption, related to full load	max. 0.5 % of fuel consumption		
Oil filling	max (l / US qts)	7.0 / 7.4		
	min (l / US qts)	6.0 / 6.3		
Speed control	Lowest idle speed	900 r.p.m.		
	Static speed droop	adjustable [0, 3, 5, 10 %]		
Installation information	Amount of combustion air at 2800 rpm approx. ¹⁾ [kg/h]	319		
	Amount of cooling air at 2800 rpm approx. ¹⁾ [kg/h]	352		
	Mass moment of inertia J [kgm ² / lb.ft ²]	J _{engine} 0.234 / 5.553		
	Starter	12 V - 2.2 kW [-25°] — 24 V - 3.0 kW [-32°] ²⁾		
Alternator charging	14 V - 110 A / 28 V - 65 A			
Battery capacity [max]	12 V - 110 Ah / 450A DIN 24 V - 66 Ah / 300A DIN			
Weight	Weight (kg / lbs.)	173 / 381 [inclusive catalyst]		158 / 348
		255 / 562 [as Open Power Unit]		

¹⁾ For other speeds there is a linear reduction in the air requirement. ²⁾ -40 °C with special approval possible.

Engine output [max]		4H50TIC .DPF	4H50TIC	4H50TI
	[r.p.m.]	kW / HP	kW / HP	kW / HP
Blocked ISO brake horsepower [IFN] for intermittent loading according to ISO 3046-1.	2800	55.0 / 74.8	55.0 / 74.8	62.0 / 84.3
	2600	54.9 / 74.6	54.9 / 74.6	62.0 / 84.3
	2300	54.0 / 73.4	54.0 / 73.4	61.2 / 83.2
	2000	50.3 / 68.4	50.3 / 68.4	55.3 / 75.2
	1800	45.2 / 61.5	45.2 / 61.5	49.7 / 67.6
	1500	37.1 / 50.4	37.1 / 50.4	40.8 / 55.5
Blocked ISO standard power output [no overload permissible] acc. to ISO 3046-1. For constant load [ICFN].	2800	49.5 / 67.3	49.5 / 67.3	—
	2600	49.4 / 67.2	49.4 / 67.2	—
	2300	48.6 / 66.1	48.6 / 66.1	—
	2000	45.2 / 61.5	45.2 / 61.5	—
	1800	40.7 / 55.3	40.7 / 55.3	—
	1500	33.4 / 45.4	33.4 / 45.4	—
Blocked ISO standard power output [no overload permissible] acc. to ISO 3046-1. For constant speed and constant load [ICFN]. - e.g. power generators	3000	50.0 / 68.0	50.0 / 68.0	50.0 / 68.0
	1800	36.4 / 49.5	36.4 / 49.5	36.4 / 49.5
	1500	28.7 / 39.0	28.7 / 39.0	28.7 / 39.0

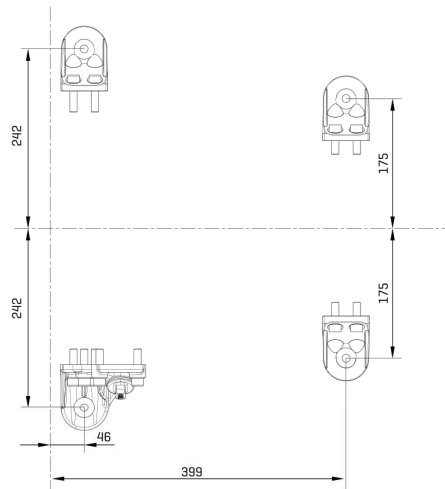
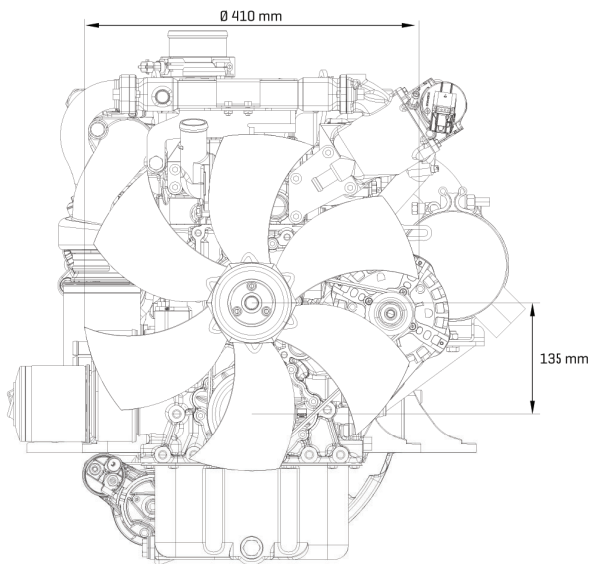
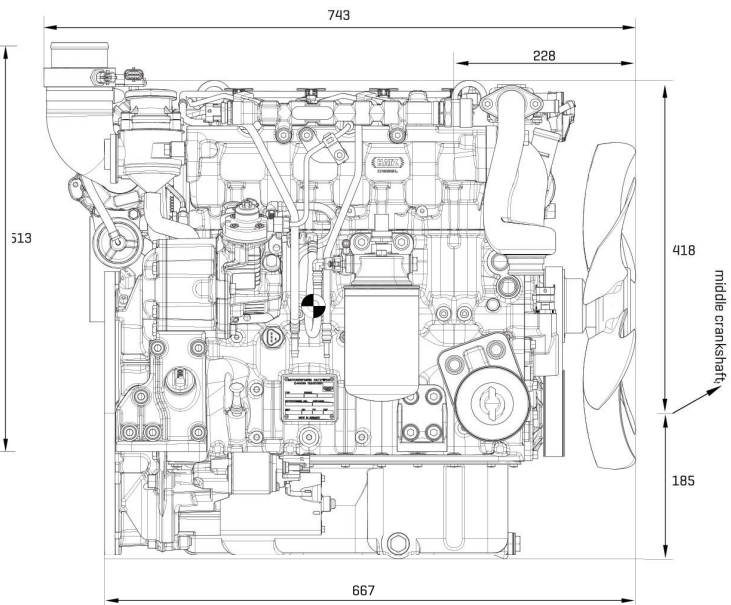
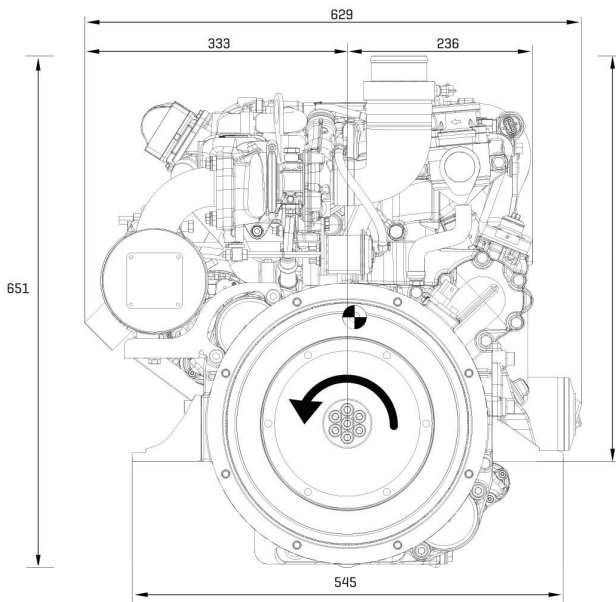

Diesel particulate filter (DPF)

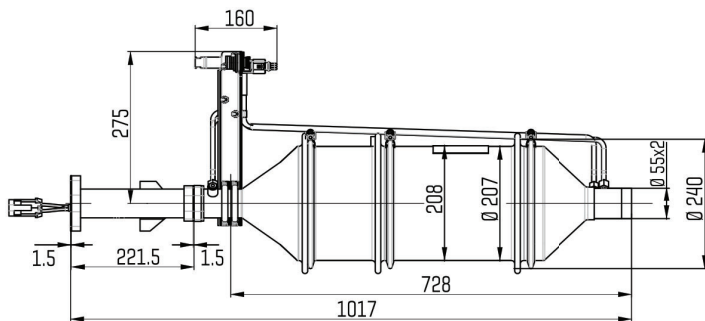

Spread at box dimensions ± 3 mm due to tolerance.
 Drawings with detail and connection dimensions as PDF resp. DXF can be found at www.HATZ-DIESEL.com.

SECTION 6 HATZ

Hatz Diesel Specifications (cont'd)

Power output, torque und fuel consumption

4H50TIC, 4H50TIC DPF

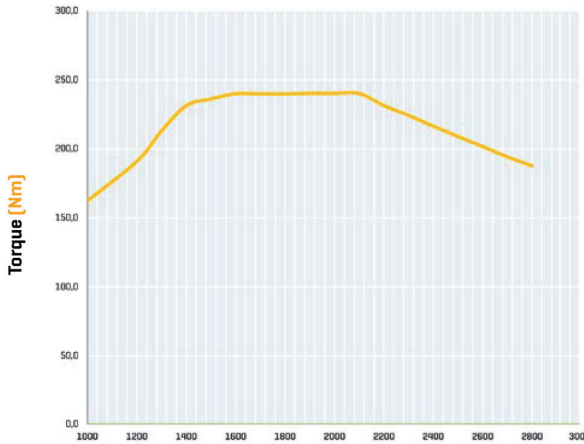

4H50TI

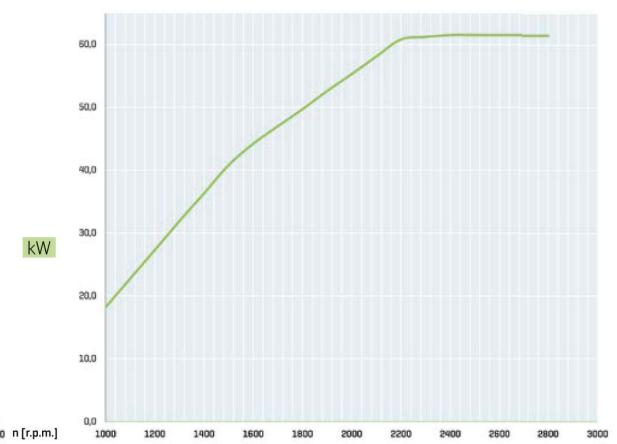
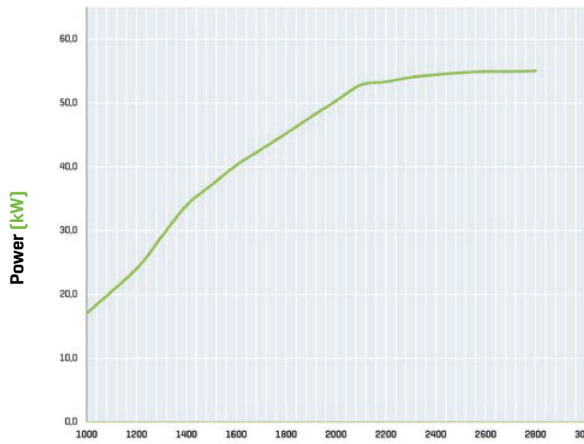
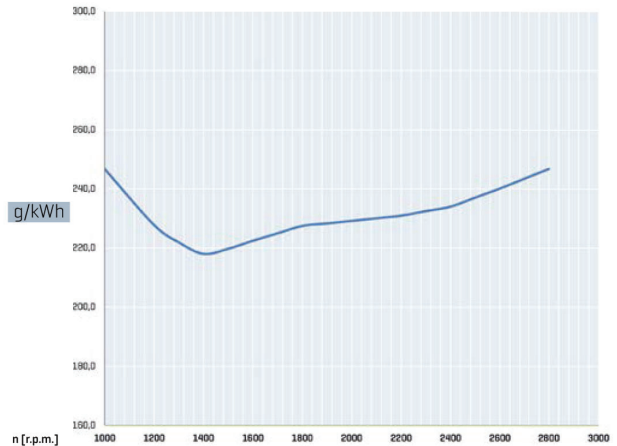
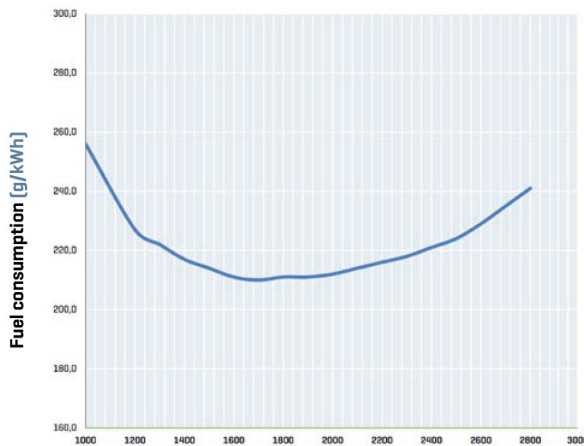
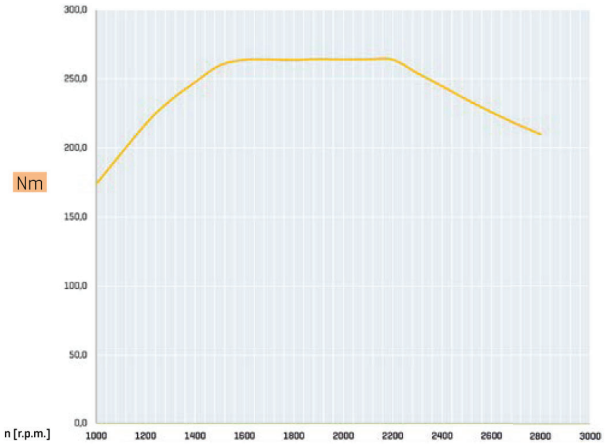

Maintenance and operating points

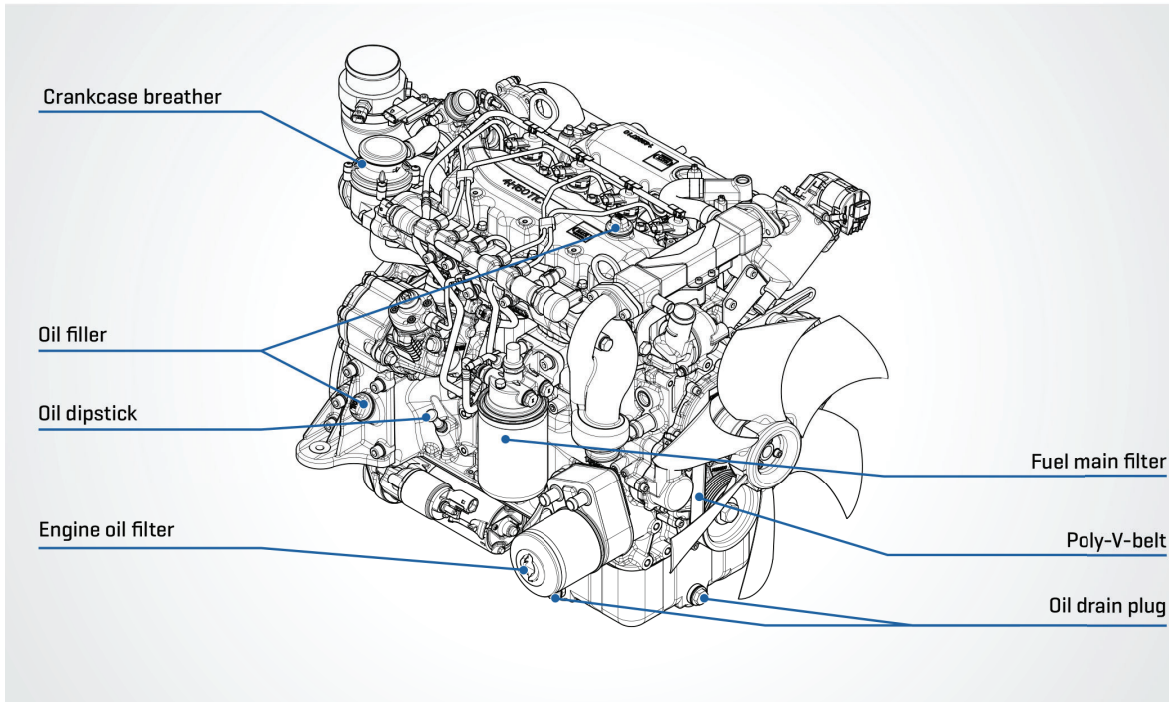

Power take off

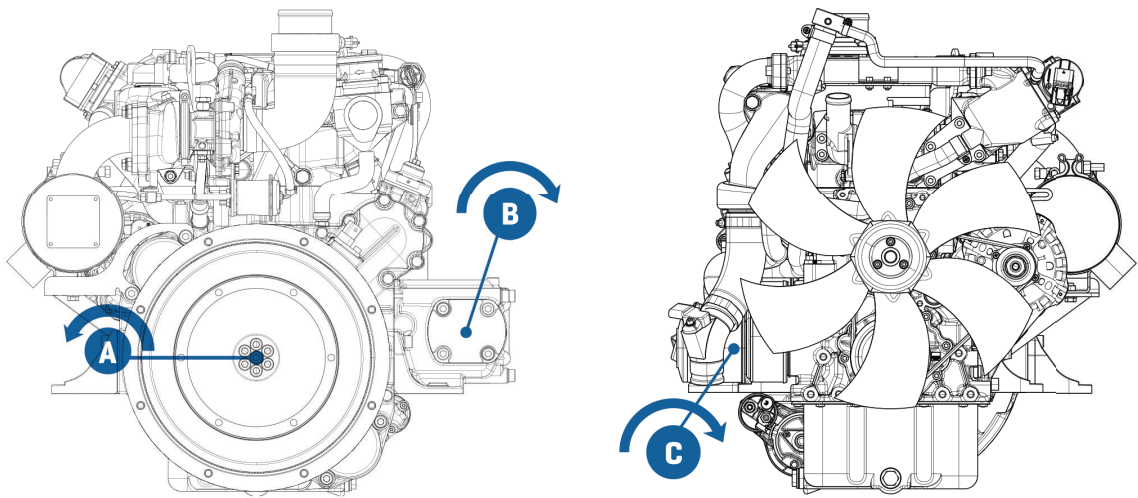

Power take off		4H50TIC
Transmittable torque	A	100%
	B	$\Sigma = 100 \text{ Nm}$
	C	

SECTION 6 HATZ

Hatz Diesel Specifications (cont'd)



The engine type plate is located on the crankcase and contains the following engine information:

1	Model designation of the engine
2	Engine serial number
3	Serial rating (kW) at nominal speed (rpm)
4	Displacement (liters)
5	Information for US emission certification (EPA/CARB)
6	EU type approval
7	EU country of origin (Germany)
8	Model year (month/year)
9	Bar code (engine serial number)

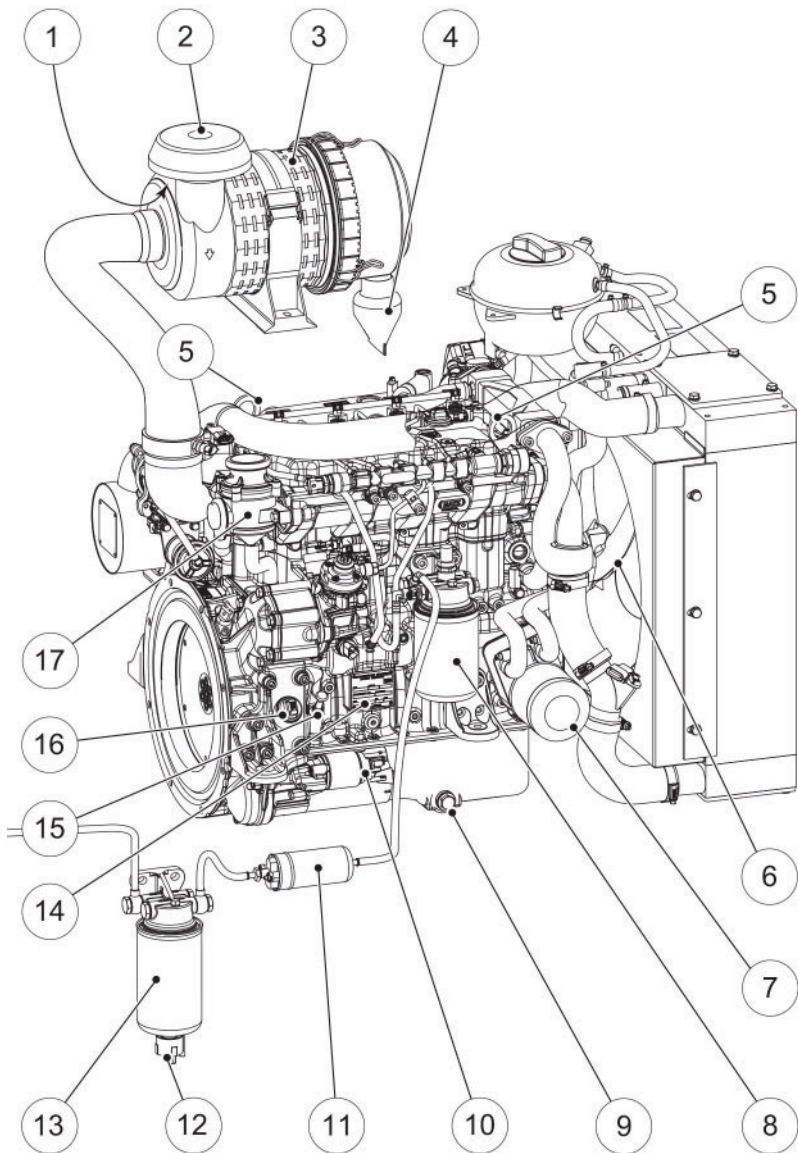

1	Intake opening for combustion air
2	Rain cap
3	Air filter (optional)
4	Dust discharge valve
5	Lifting eyes
6	Fan
7	Oil filter
8	Fuel fine filter
9	Side oil drain screw
10	Starter (low mounting position)
11	Electric fuel pump
12	Drain plug on fuel prefilter
13	Fuel prefilter
14	Engine type plate
15	Dipstick
16	Oil filler plug, bottom
17	Crankcase ventilation

SECTION 6 HATZ

Hatz Diesel Specifications, 3H50TIC

HATZ 3H50TIC TECHNICAL DATA

TYPE	LIQUID COOLED 4 STROKE ENGINE
ENGINE OUTPUT (MAX)	43.6 kW/58.5 HP
INJECTION SYSTEM	DIRECT INJECTION
BORE X STROKE	84 X 88 MM (3.30 x 3.46 IN)
DISPLACEMENT	1.464 L (89.34 CU IN)
COMPRESSION RATIO	17.5:1
OIL CAPACITY	MAX - 5.2 QTS
	MIN - 4.4 QTS
LOWEST IDLE SPEED	900 RPM
ENGINE RPMS	1500, 1800, 2300, 2800 RPM
WEIGHT**	236 KG (520 LB)
DIMENSIONS** - L X W X H	31.7 X 27 X 31.8 IN

*AEC Part Number:

068387 - Engine, Hatz 3 Cylinder

070325 - Kit, Hatz Engine 3H50TIC

**Extended Declaration of Incorporation
EC Machinery Directive 2006/42/EC**

The manufacturer: **Motorenfabrik Hatz GmbH & Co.KG
Ernst-Hatz-Straße 16
D-94099 Ruhstorf a. d. Rott**

hereby declares that the incomplete machine: product description: **Hatz diesel engine**

Type designation and as of serial number:

3H50TIC = 13510, 3H50TI = 16310

4H50TIC = 13610, 4H50TI = 16110

satisfies the following basic safety and health protection requirements in acc. with Annex I to the above-mentioned Directive.

- Annex I, General principles no. 1
- Nr. 1.1.2., 1.1.3., 1.1.5., 1.2.1., 1.2.2., 1.2.3., 1.2.4.1., 1.2.4.2., 1.3.1., 1.3.2., 1.3.3., 1.3.4., 1.3.7., 1.3.8.1., 1.4.1., 1.5.1., 1.5.2., 1.5.8., 1.5.9., 1.6.1., 1.6.2., 1.6.4., 1.7.

All relevant basic safety and health protection requirements down to the interfaces described

in the manual for diesel engine

in the enclosed data sheets

in the enclosed technical documents

have been complied with.

The special technical documents in acc. with Annex VII B of the Directive 2006/42/EC have been prepared.

Conformity with the provisions of the following, other EC Directives, i.e.

- **2014/30/EU Electromagnetic Compatibility (EMC)**, dated 26.02.2014

(was tested in association with a generator)

The following standards have been used (completely or partially):

- EN 1679-1: 092011

- EN ISO 12100: 032011

- EN ISO 13857: 062008

- EN 60204-1: 062007

- EN ISO 13849-1: 062016

The manual for diesel engine has been enclosed to the incomplete machine and the Assembly Instructions have been provided to the customer electronically together with the order confirmation.

Commissioning has been prohibited until it has been established, if applicable, that the machine into which the above-mentioned incomplete machine is to be incorporated, satisfies the provisions of the Machinery Directive.

Wolfgang Krautloher / see "Manufacturer"

Name / address of EC documentation officer

03.07.2017

Krautloher / Directives official

Date

Signature and information on the undersigned



Signature

Engine Maintenance Schedule

SECTION 6 HATZ

Symbol	Maintenance interval	Maintenance activity/check
8-15h	Every 8–15 operating hours or every day before starting	Check the oil level.
		Check the intake area of the combustion air.
		Check the radiator fins for dirt accumulation.
		Check the cooling system
500h	Every 500 operating hours or every 2 years	Change the engine oil and oil filter ¹⁾
		Change the fuel prefilter ¹⁾
		Replace the main fuel filter ¹⁾
		Check the poly v belt ¹⁾
		Change the oil separator of the crankcase ventilation ¹⁾
		Check the screw connections ¹⁾
	Every 500 operating hours or when indicated, at least every 2 years	Change the air filter cartridge
	When indicated, at least every 2 years	Drain the water separator ¹⁾
	Every 4 years	Change the coolant
	If necessary, but every 3,000 operating hours at the latest	Replace the poly v belts
	Every 4,000 operating hours	Clean the entire exhaust gas recirculation section (EGR pre- cooler, EGR valve, EGR main cooler as well as EGR mixing nozzle) (to be carried out by a trained specialist)

- Maintenance tasks may only be performed by trained personnel.
- Accident prevention measures must be in accordance with the local accident prevention regulations.
- Perform setting and maintenance work at the specified intervals.
- Replace faulty machine parts as soon as possible.
- Always wear personal protection equipment.
- Only use fully functional tools.
- Installation of unsuitable spare parts can lead to problems. We cannot accept responsibility for direct damage or secondary damage that results from this. We therefore recommend the use of Hatz original spare parts.
- Closely adhere to the maintenance conditions prescribed in this manual.
- Only make changes to the machine in agreement with the manufacturer.
- Only perform maintenance work when the engine is stopped.
- Protect the starting key from unauthorized access.
- Disconnect the negative battery terminal before carrying out maintenance work.
- Adhere to legal regulations when handling and disposing of used oil, filters, coolants, and cleaning agents.
- After completing maintenance work, check that all tools, bolts, aids, and other objects are removed from the machine, and that all safety equipment has been replaced.

SECTION 6 HATZ

Air Cleaner Maintenance

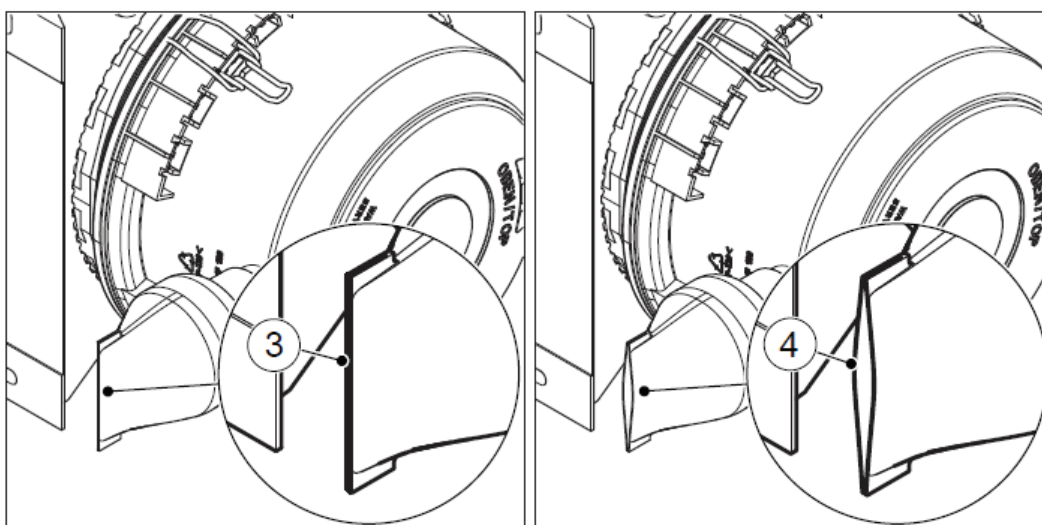
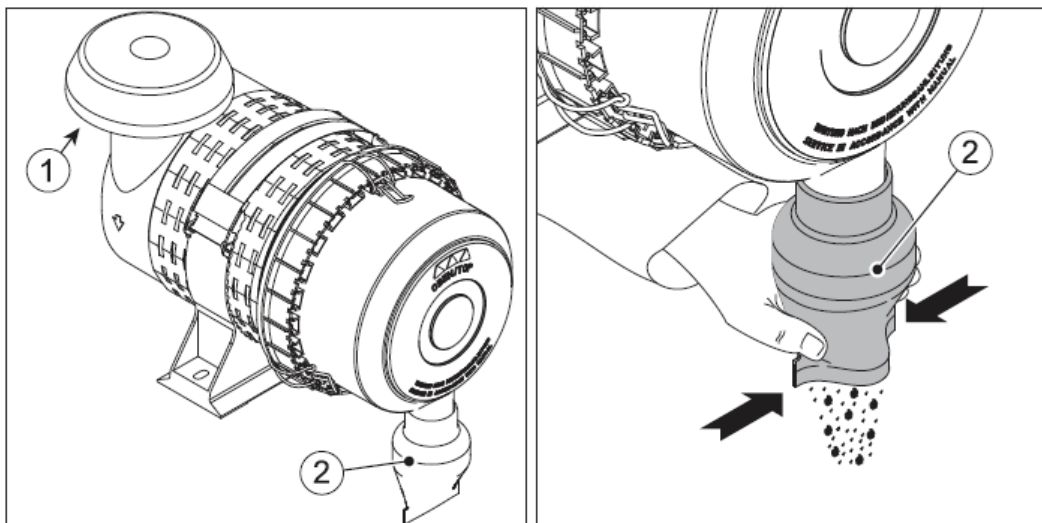

1	Intake opening for combustion air
2	Dust discharge valve
3	Rubber lips OK
4	Rubber lips deformed

Step Activity

1. Check the intake opening (1) for coarse contamination such as leaves, heavy dust deposits, etc., and clean if necessary.
2. Check that the dust discharge valve (2) is clear. Remove dust seals by pressing them together.
3. Make sure that the rubber lips (3) run parallel to each other. The gap between the rubber lips must be a maximum of 2 mm. Deformed rubber lips (4) impair the function of the precleaner, thus shortening the maintenance interval of the air filter. Replace the dust discharge valve if required.

TRTP Maintenance Schedule

SECTION 6 HATZ

CHECK LIST					
ITEM	DAILY	EVERY 20 HRS	EVERY 50 HRS	EVERY 100 HRS	EVERY 300 HRS
Hydraulic Oil Level	✓				
Fuel Level	✓				
Hoses and Fittings	✓				
External Hardware	✓				
Change Engine Oil				✓	
Grease Bearings		✓			
Replace Fuel Filter					✓
Replace Oil Filter				✓	
Check Valve Clearance			✓		
Air Filter	✓				
Hydraulic Motors			✓		
Steering Leg			✓		
Hydraulic Filters	✓				

SECTION 6 HATZ

Filter Replacement Pre-Fuel Filter

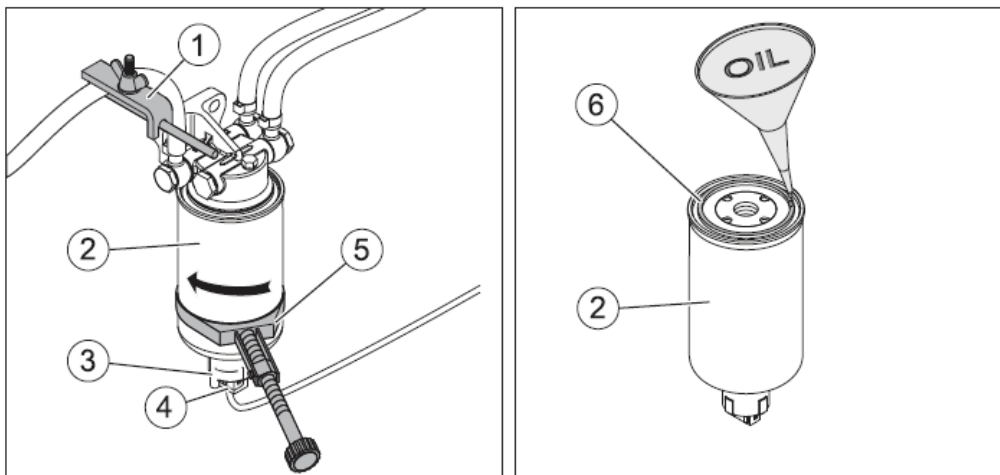

1	Hose clip on fuel feed line
2	Fuel prefilter
3	Drain plug with integrated water level sensor
4	Water level sensor cable
5	Strap wrench
6	Gasket

Step Activity

1. Lock the fuel supply line on the fuel prefilter.
2. Place a suitable container under the filter to collect emerging fuel.
3. Disconnect the water level sensor cable (4) from the drain plug (3).
4. Release the drain screw (3) and drain the fuel.
5. Unscrew the fuel prefilter. Completely unscrew the drain plug with integrated water level sensor
6. Dispose of the used fuel prefilter according to local environmental regulations.
7. Clean the drain plug with integrated water level sensor and lightly oil the sealing surfaces. Screw the drain plug into the new fuel prefilter.
8. Lightly oil the gasket (6) of the new fuel prefilter, fit the dry filter and tighten it by hand.
9. Release the fuel feed line and connect the cable of the water level sensor.
10. Start the engine and perform a test run.
11. After the test run, check the fuel prefilter and drain plug for leaks, tighten by hand if necessary.

PRE-FUEL FILTER PART NUMBER: 065851

Filter Replacement (cont'd) Fuel Filter

SECTION 6 HATZ

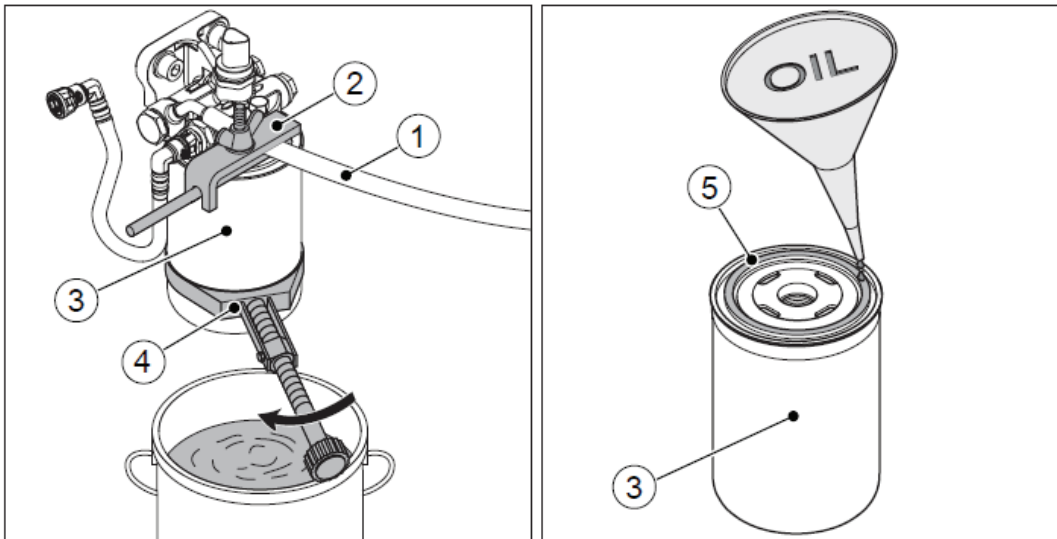

1	Fuel feed line
2	Hose clip
3	Main fuel filter
4	Strap wrench
5	Gasket

Step Activity

1. Block the fuel feed line (1) using the hose clip (2).
2. Place a suitable container under the filter to collect emerging fuel.
3. Unscrew the main fuel filter (3) and dispose of it according to local environmental regulations.
4. Lightly oil the gasket (5) of the new main fuel filter.
5. Fit the filter and tighten it by hand.
6. Release the fuel feed line.
7. Start the engine and perform a test run.
8. After the test run, check the main fuel filter for leaks and tighten by hand if necessary.

FUEL FILTER PART NUMBER: 065852

SECTION 6 HATZ

Filter Replacement (cont'd) Oil Separator

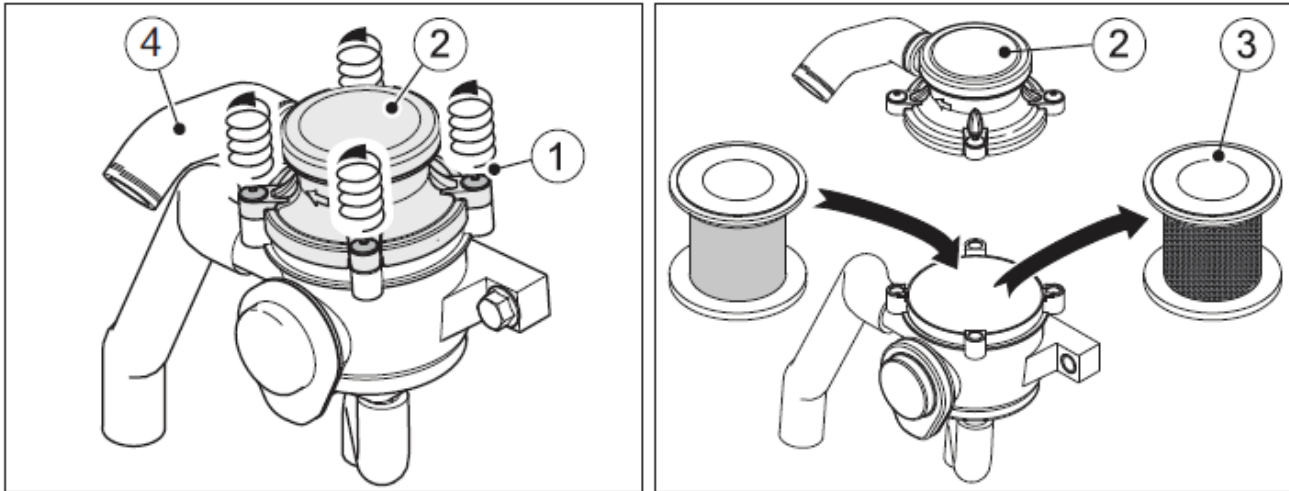

1	Mounting bolts (captive)
2	Breather cap
3	Oil separator cartridge
4	Vent hose

Step Activity

1. Release the four mounting bolts (1) on the breather cap (2).
2. Carefully lift the breather cap. If necessary, release the vent hose (4).
3. Remove the used oil separator cartridge and dispose of it according to local environmental regulations.
4. Wipe out the breather housing with a clean cleaning cloth. Make sure that dirt is not brought into the breather housing.
5. Insert a new oil separator cartridge.
6. Put on the breather cap and tighten the four mounting bolts (max. 4 Nm). If necessary, reattach the vent hose.

OIL SEPARATOR PART NUMBER: 065853

Filter Replacement (cont'd) Oil Filter

SECTION 6 HATZ

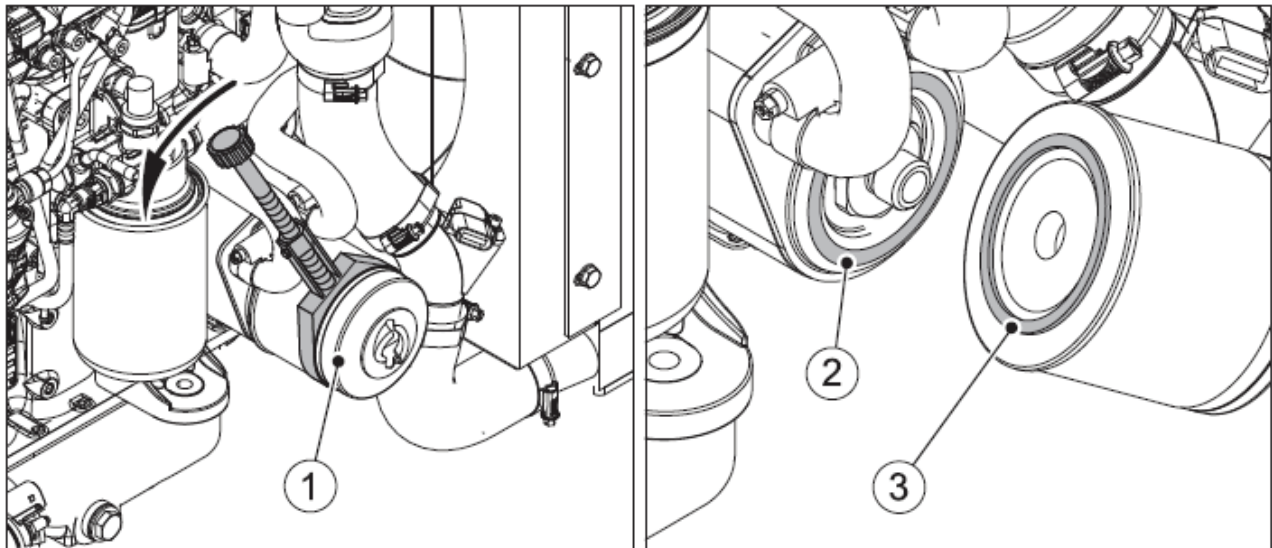

1	Oil filter
2	Sealing surface
3	Gasket

Step Activity

1. Keep a container ready for collecting the used oil.
2. Loosen the oil filter (1) with a strap wrench or similar and unscrew it.
3. Dispose of the old filter in accordance with local environmental regulations.
4. Thoroughly clean the sealing surface (2).
5. Lightly oil the sealing lip (3) of the new oil filter.
6. Screw in the oil filter and tighten it by hand.

OIL FILTER PART NUMBER: 065854

SECTION 6 HATZ

Filter Replacement (cont'd) Air Filter

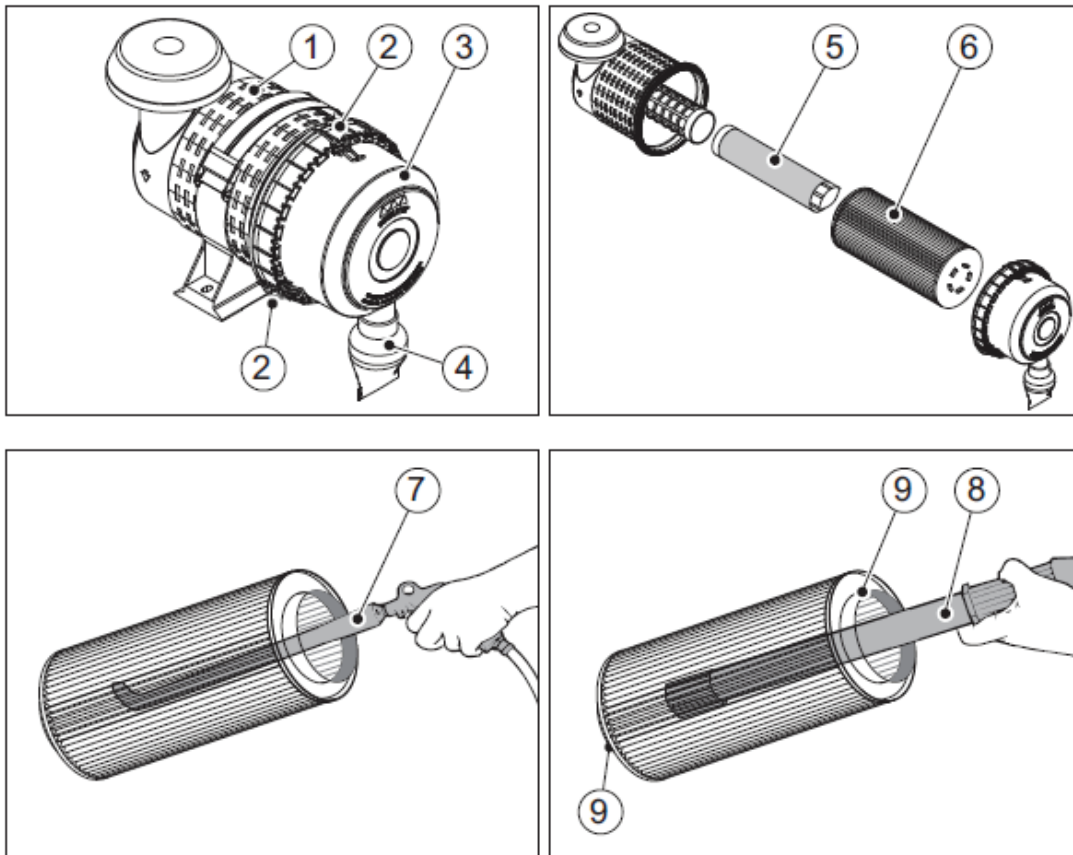

1	Air filter housing
2	Retaining clips
3	Air filter cover
4	Dust discharge valve
5	Secondary filter
6	Primary filter
7	Air gun with extension tube (tip bent)
8	Lamp
9	Sealing surfaces

Replacing the primary/secondary filters

Step Activity

1. Open the retaining clips (2) and remove the air filter cover (3).
2. Pull out the primary filter (6) and either replace (recommended) or clean (see below). Replace or clean the primary filter according to the service interval indicator. The primary filter must be replaced every two years at the latest however, cleaning is no longer possible after this time.
3. Remove dirt adhering to the inside of the air filter housing (1), air filter cover (3), and dust discharge valve (4).
4. Pull out and check the secondary filter (5), replace if required. The secondary filter can not be cleaned. The secondary filter must be replaced after every fifth replacement of the primary filter, though no later than every two years.
5. Carefully insert new filter elements.
6. Place the air filter cover on the air filter housing and lock all retaining clips making sure that the dust discharge valve points vertically downwards.

Cleaning the primary filter

Step Activity

1. Blow out the primary filter (6) with dry compressed air from the inside to the outside until dust no longer emerges. Use an air gun with an extension tube (7) with the end bent by approx. 90°. The end of the extension tube must not touch the filter paper.
2. Check the sealing surfaces (9) of the filter cartridge for damage.
3. Check the filter cartridge for tears or other damage in the filter paper by holding it against the light at a slant or shining light from a lamp (8) through it. In case of doubt, always replace the primary filter.

NOTE: The primary filter may only be cleaned once, then it must be replaced.

SECONDARY AIR FILTER PART NUMBER: 065855

PRIMARY AIR FILTER PART NUMBER: 065856

SECTION 6 HATZ

Troubleshooting

Area	Malfunction	Possible Cause	Corrective Measure	Ref.
Engine	Engine does not start, or is difficult to start	Battery is discharged	- Add battery fluid - Charge the battery - Replace the battery	
		Battery cable is disconnected	- Connect battery cable	
		Blown fuse	- Replace fuse	
		Bad connection or breakage in the wiring	- Contact your AEC dealer	
		Out of fuel	- Fill fuel	
		Air is in fuel	- Contact your AEC dealer	
		Engine fouled	- Wait a while and try starting again	
		Insufficient or wrong oil	- Fill or change oil	
		Dirty or damaged spark plug	- Clean or replace spark plug	
		Contamination in fuel system	- Contact your AEC dealer	
		Other (other than above)	- Contact your AEC dealer	
	Engine stalls	Out of fuel	- Fill fuel	
		Cold engine	- Warm up the engine	
		Other (other than above)	- Contact your AEC dealer	
	Engine stops abruptly	Out of fuel	- Fill fuel	
		Piston seizure due to insufficient or bad oil	- Contact your AEC dealer	
		Other (other than above)	- Contact your AEC dealer	
	Engine does not stop	Electrical malfunction	- Contact your AEC dealer	
		Other (other than above)	- Contact your AEC dealer	
	Idling is not stable	Insufficient intake air (clogged air cleaner)	- Clean or replace the air cleaner	
		Other (other than above)	- Contact your AEC dealer	
	Poor power or acceleration	Bad fuel	- Change fuel	
		Wrong oil (improper viscosity)	- Change to suitable oil	
		Accelerator (throttle) is not properly adjusted	- Contact your AEC dealer	
		Insufficient intake air (clogged air cleaner)	- Clean or replace the air cleaner	
		Excessive load	- Reduce load	
		Loose drive belt	- Adjust	
		Other (other than above)	- Contact your AEC dealer	
	Irregular noise or vibration from or around the engine		- Contact your AEC dealer	
	Excessive oil consumption		- Contact your AEC dealer	
	Engine overheats	Insufficient amount of engine oil	- Fill oil	
		Cooling fan is clogged or blocked	- Clean	
Other (other than above)		- Contact your AEC dealer		
Excessive fuel consumption	Clogged air cleaner	- Clean or replace air cleaner		
	Other (other than above)	- Contact your AEC dealer		

Area	Malfunction	Possible Cause	Corrective Measure	Ref.
Engine	Black smoke comes out of exhaust	Bad fuel	- Change fuel	
		Clogged air cleaner	- Clean or replace the air cleaner	
		Choke is not fully open	- Open the choke fully	
		Other (other than above)	- Contact your AEC dealer	
	White or blue smoke comes out of exhaust	Engine oil level is too high	- Adjust the oil level	
	Other (other than above)	- Contact your AEC dealer		
Safety Devices	Lamp does not light	Blown bulb	- Replace	
		Blown fuse	- Replace	
		Other (other than above)	- Contact your AEC dealer	
Hydraulic System	Pump does not work	Insufficient or deteriorated hydraulic fluid	- Add or change fluid	
		Other (other than above)	- Contact your AEC dealer	



SECTION 6
HATZ

Hatz Diesel Engine Assembly
Illustration

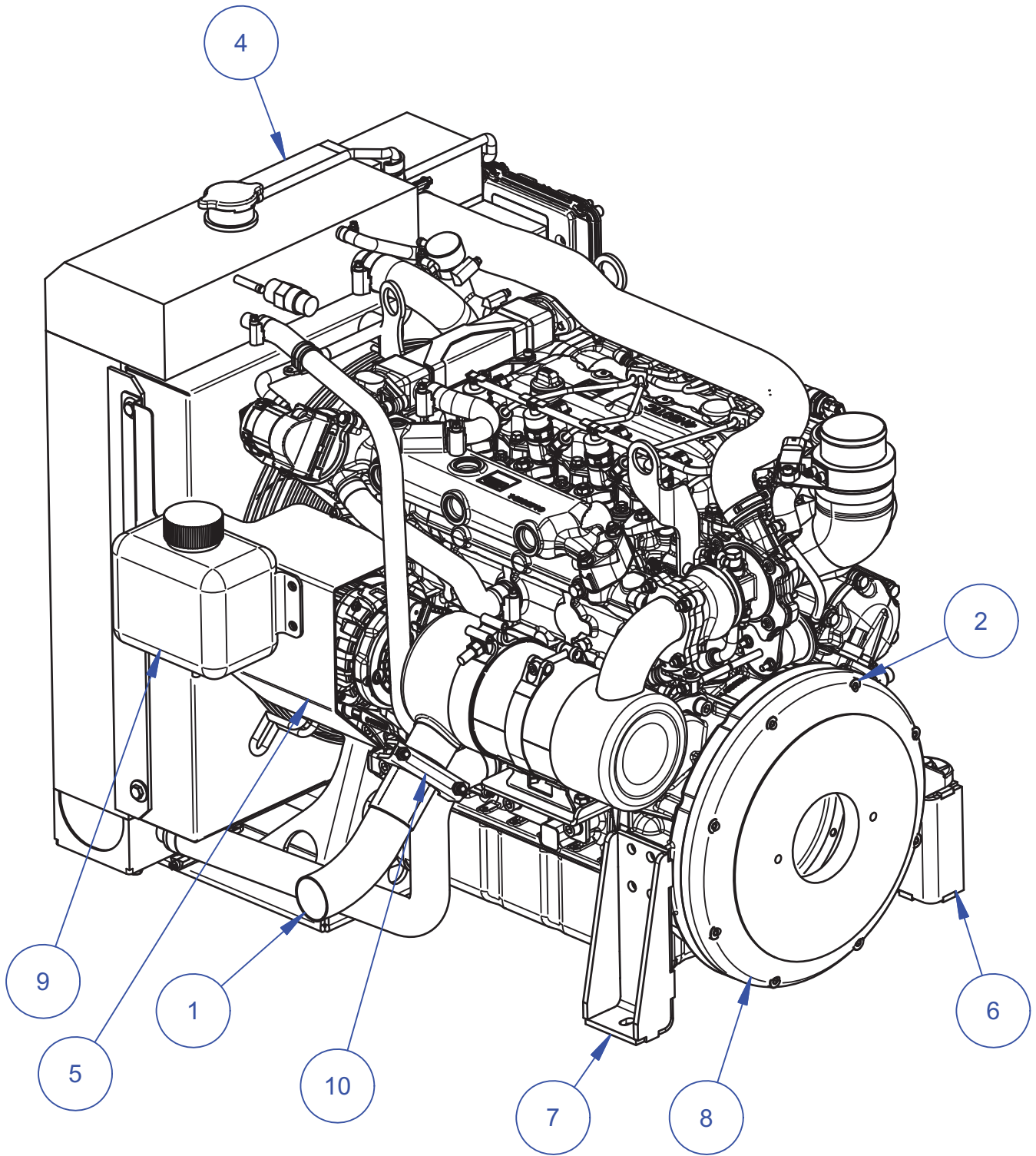

Hatz Diesel Engine Assembly Parts List

SECTION 6 HATZ

ITEM	PART NO.	DESCRIPTION	QTY
1	049739	EXHAUST TAIL PIPE FOR HDX740 CUMMINS	1
2	065243	FSTN, SHCS M10 X 1.5 X 30 MM GRADE 12.9 LONG ULTRA CORROSION	8
3	065398	AUXILIARY DRIVE FOR HATS H50 ENGINE	1
4	065453	HATZ ENGINE H50 1800 RPM	1
5	065454	BRACKET, COOLANT OVER FLOW BOTTLE MNT. HATZ TRTP	1
6	065470	ENGINE MOUNT, REAR FRONT FOR HATZ ENGINE ON TRTP	1
7	065474	ENGINE MNT, REAR LH FOR 255TRTF WITH HATZ	1
8	065486	PUMP MOUNTING PLATE (HAYES043-0-HC4-91-B2) FOR HATZ ENGINE SAE "B" 2 BOLT	1
9	066028	COOLANT RECOVERY BOTTLE F/ HATZ ENG.	1
10	066139	CLAMP, 2 1/4" MUFFLER	1

SECTION 6 HATZ

Power End Assembly Illustration

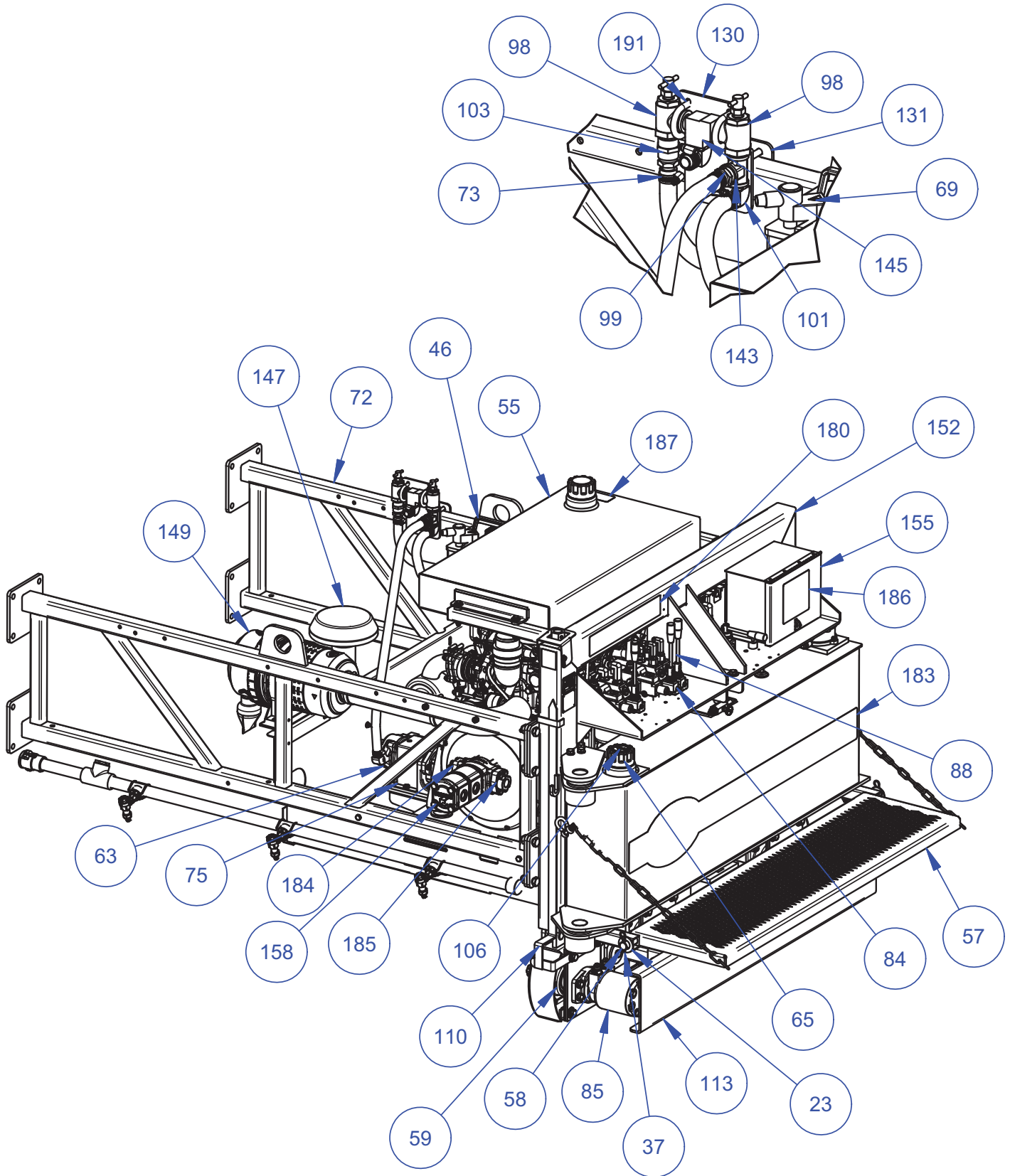

Power End Assembly Parts List

SECTION 6 HATZ

ITEM	PART NO.	DESCRIPTION	QTY
1	010001	FSTN, HHCS 1/4-20 X 1/2 GR 5	1
2	010002	FSTN, HHCS 1/4-20 X 3/4	3
3	010007	FSTN, HHCS 1/4-20 X 2	2
4	010014	FSTN, HHCS 1/4-20 X 3	1
5	010018	FSTN, HHCS 5/16 -18 X 1/2 GRADE 8	1
6	010019	FSTN, HHCS 5/16-18 X 3/4 GR 5	2
7	010021	FSTN, HHCS 5/16-18 X 1-1/4 GR5	4
8	010023	FSTN, HHCS 5/16-18 X 1-3/4	2
9	010027	FSTN, HHCS 5/16-18 X 2-1/2 GR5	3
10	010034	FSTN, HHCS 3/8-16 X 1/2	1
11	010043	FSTN, HHCS 3/8-16 X 2-3/4	4
12	010044	FSTN, HHCS 3/8-16 X 3	2
13	010045	FSTN, HHCS 3/8-16 X 3-1/4	4
14	010046	FSTN, HHCS 3/8-16 X 3-1/2	3
15	010067	FSTN, HHCS 1/2-13 X 1 GR8	6
16	010068	FSTN, HHCS 1/2-13 X 1-1/4 GR 8	5
17	010069	FSTN, HHCS 1/2-13 X 1-1/2 GRADE 8	36
18	010070	FSTN, HHCS 1/2-13 X 2-1/4 GR 5	2
19	010081	FSTN, FW 1/4	4
20	010082	FSTN, FW 5/16	5
21	010083	FSTN, FW 3/8	13
22	010085	FSTN, FW 1/2 GR8	16
23	010088	FSTN, FW 1"	2
24	010089	FSTN, LW 1/4	1
25	010090	FSTN, LW 5/16	10
26	010091	FSTN, LW 3/8	13
27	010092	FSTN, LW 7/16 GR 8	1
28	010093	FSTN, LW 1/2 GR8	29
29	010096	FSTN, Ø7/16 ID Y-ZINC HRDND FLAT	1
30	010100	FSTN, NUT HEX 5/16-18 GR8	3
31	010102	FSTN, NUT HEX 3/8-16	4
32	010104	FSTN, HEX NUT 7/16-14 GR 8	1
33	010110	FSTN, NUT HEX 5/8-11 GR 8	16
34	010464	FSTN, NUT NYLOK 3/8-16 GR 8	20
35	010498	PLUG, 3/8 NPT BI SQ HD PIPE	2
36	010513	FITTING, 1/4-28 STR GREASE	3
37	010711	CLIP, .125x2-9/16 HITCH PIN	2
38	011238	FSTN, NUT HEX NYLOK 1/2-13	17
39	012994	RIVET, 1/8x3/8 ALUM DOME HD [closed]	4
40	015692	CAP, Ø1/4 RED GREASE	3
41	015713	BUSHING, NITRILE	4
42	017751	FSTN, FW HARD A325 3/8 (p)	3
43	020542	FSTN, NUT STOVER LOCK 1/4-20	6
44	023915		1

SECTION 6
HATZ

Power End Assembly (cont'd)
Illustration

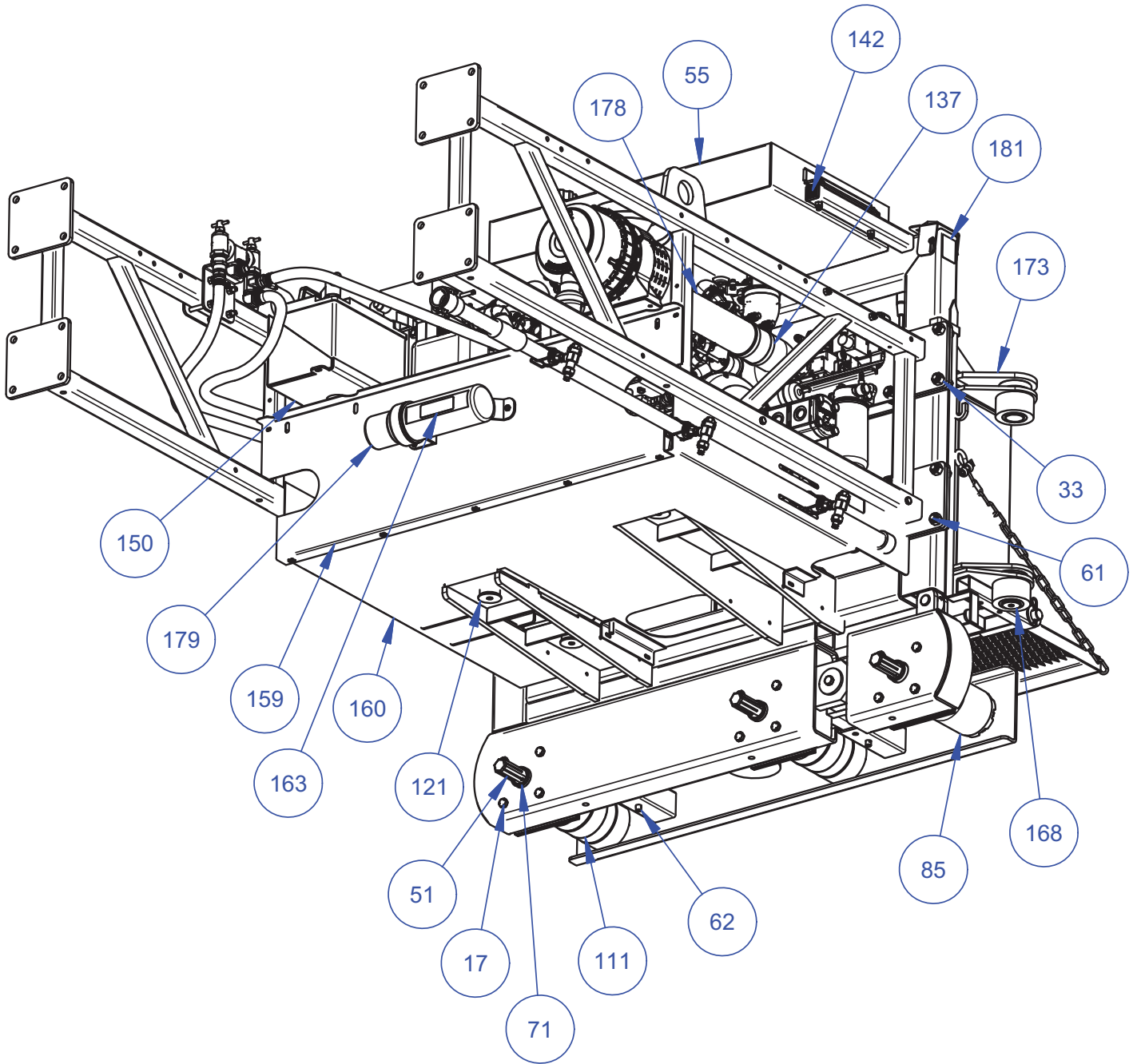

Power End Assembly (cont'd) Parts List

SECTION 6 HATZ

ITEM	PART NO.	DESCRIPTION	QTY
45	024669	FSTN, HHCS 7/16-14 X 2	4
46	026592	BATTERY HOLD DOWN STRAP	1
47	028279	MOTOR MOUNT PLATE	3
48	028287	PAD, FOOT F/CYLINDER TRTF	1
49	028291-1	PIN, SHORT F/ CYLINDER TRTF	1
50	028291-2	PIN, LONG F/ CYLINDER TRTF	1
51	028292	SHAFT, HEX TRIPLE RTF	3
52	028322	MOUNT, CYLINDER FOR TRTP	1
53	028402	FSTN, HHCS 3/8-16 x 1-1/2 GR8	8
54	029032	DIN 127 - M8	6
55	029127	TANK, FUEL	1
56	029136	ENDHANDLE LOCK	1
57	029176	STAND, TRTF	1
58	029187	BAR, F/ OPERATOR STAND	1
59	029223	BEARING, 1 3/4" 4 BOLT FLANGE	3
60	029232	VALVE, CHECK PNEUTROL 3/8 TRTF	1
61	029311	FSTN, HHCS 5/8-11 X 1 3/4 GR 8 YELLOW ZINC	16
62	029387	PIN, MOTOR PROTECTOR TRTP 255	2
63	029418	PUMP, 6500C-R	1
64	032097	DECAL, SERIAL NUMBER PLATE	1
65	032268	UNIT, CHROME LOCKABLE GAS-HYDRA TANK CAP	2
66	032863	FSTN, HHCS M8 x 1.25 x 20MM	6
67	034243	DECAL, HYDR OIL ONLY	1
68	035597	INSULATOR, POS BATT TERMINAL	1
69	035598	INSULATOR, NEG BATT TERMINAL	1
70	037230	BRACKET, TRTP LONG BALL VALVE	1
71	037560	O-RING, HEX COUPLER ASSY (318)	3
72	037577	FRAME, TRTP 6' END	2
73	038664	#10 HOSE CLAMP	7
74	038882	CUSHION,BATT.BOX REAR F/TRTF	1
75	039788	GUARD, F/HYD. WATER PUMP TRTP	1
76	039789	SPACER, BLOCK F/WATER PUMP F/TRTP	1
77	040058	VALVE, STACK (FINISH TUBE CONTROL) TRTP	1
78	040059	FOOT BRACKET, WATER PUMP TRTP	1
79	040060	COUPLER, JAW F/ WATER PUMP (TRTP)	2
80	040061	INSERT, JAW COUPLER WATER PUMP TRTP	1
81	040063	VALVE, SPRAY SYSTEM (TRTP)	1
82	040064	HANDLE, WATER SPRAY VALVE (TRTP)	1
83	040065	MOTOR, WATER PUMP (TRTP)	1
84	040066	VALVE, STACK (TRAVEL CONTROL) TRTP	1
85	040068	MOTOR, FINISH 10" TRTP (STRIKE OFF)	1
86	040072	STRAINER, SMALL HYD. TMF-05-5 TANK (TRTP)	1
87	040073	STRAINER, LARGE HYD. TANK (TRTP)	2
88	040074	HANDLE, F/ VALVE - TRTP	3
89	040076	FTG, MJIC X MSAE ADJ (8-10 90°)	1

SECTION 6
HATZ

Power End Assembly (cont'd)
Illustration

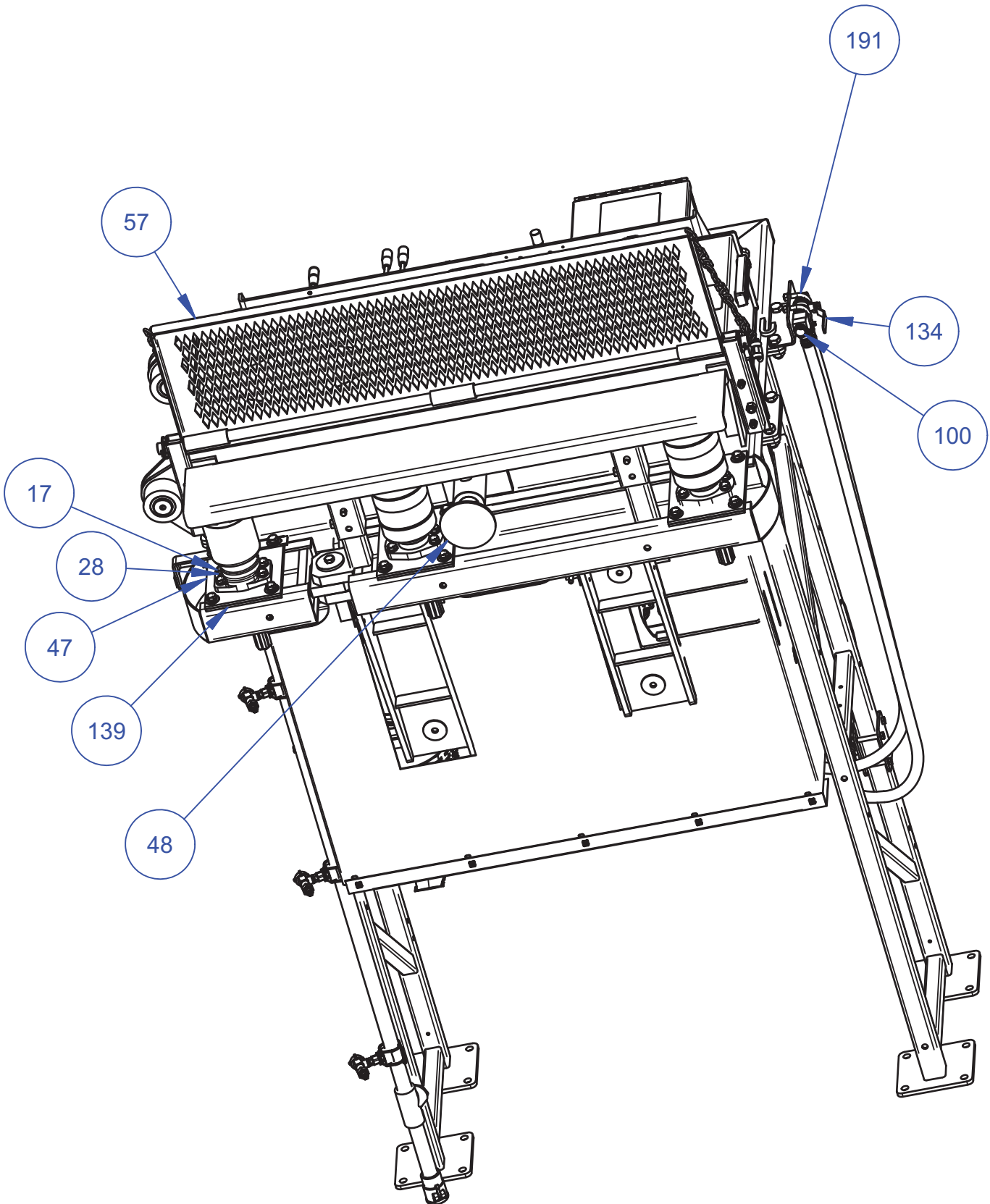

Power End Assembly (cont'd) Parts List

SECTION 6 HATZ

ITEM	PART NO.	DESCRIPTION	QTY
90	040078	*Varies*	2
91	040079	FTG, O-RING ADAPTOR (8-6)	4
92	040080	FTG, MJIC X MSAE ADJ (6-6 90°)	3
93	040083		3
94	040085	FTG, O-RING ADAPTOR (6-8)	2
95	040104	FTG, MJIC X MSAE ADJ X-LONG (6 90°)	2
96	040105	FTG, MJIC X MSAE ADJ LONG (8 90°)	1
97	040106	FTG, MJIC X MSAE ADJ (8-6 90°)	2
98	040107	RELIEF VALVE, TRTP SPRAY SYSTEM	2
99	040108	FTG, 3/4 MPT x 3/4 HOSE BARB	4
100	040109	FTG, 3/4 MPT x 3/4 GARDEN	1
101	040110	FTG, 3/4 MPT x 3/4 90° HOSE BARB	4
102	040111	FTG, 3/4 MPT RUN TEE	1
103	040115	FTG, 3/4 COUPLER	1
104	040116	FTG, 3/4 CLOSE NIPPLE	1
105	040208	FSTN, 1/2-13 STOVER NUT	4
106	041509	DECAL, HYDRAULIC OIL CAP	1
107	042816	FITTING, #6JICMX#10SAE-OR-M 90 FLARE	1
108	042821	FITTING, #JICMX3/8MPT STGT. FLARE-O	2
109	042844	GAUGE, SNA HYDR LEVEL	1
110	042945	WELD'T POINTER MOTOR END 255 TRTP	1
111	044652	MOTOR, 10" TRTP HD HYDR TRAVEL	2
112	044653	FITTING, F2603-4-4-4-O	1
113	044671	WELD'T, 255BD HD MOTOR PROTECTOR	1
114	045134	FILTER, RETURN LINE RTF25N-D10B/S2/N	1
115	045135	MANIFOLD, SPECIAL F/ TRTP	1
116	045136	CYLINDER, STEERING F/ TRTP	1
117	045137	FTG., F2501-12-12-O	1
118	045140	FTG., 6409-6-O	1
119	045141	FTG., 5406-16-12	1
120	045142		2
121	045757	MOTOR MOUNT ISOLATOR	4
122	045855	FSTN, HHCS 1/2-13 X 3-1/2 GR8	1
123	045920	FTG, F6801-8-8-NWO 90° ELB	3
124	045921	FTG, F6400-8-8-O STR	2
125	045928	FTG, F6400-4-4-O STR JIC-SAE	1
126	045940	FTG, F6400-10-10-O STR	1
127	045950	FTG, F6400-6-12-O STR	1
128	045951	FTG, F6400-8-12-O STR	2
129	046241	GAUGE, RETURN FILTER	1
130	046373	BRACKET, WATER VALVE MNT PLATE	1
131	046374	BRACKET, CLAMP PLATE WATER VALVE	1
132	046441	COVER, FUEL PUMP	1
133	047172	GAUGE, 3" SITE LEVEL	1

SECTION 6 HATZ

Power End Assembly (con't) Parts List

ITEM	PART NO.	DESCRIPTION	QTY
134	047412	3/4 NPT Ball Valve	1
135	047474	PLUG, SAE-4 O-RING	2
136	047604	BATTERY, 700CCA 12V 48-B	1
137	047850	CLAMP, TORQUE	3
138	048739		1
139	049322	PLATE, SPACER F/ TRTP DRIVE MOTORS	3
140	049425	CLAMP, J49 3/4" DIXON TRTP	1
141	049739	EXHAUST TAIL PIPE FOR HDX740 CUMMINS	1
142	050684	PLUG, 1-1/2 SQ PLASTIC	2
143	057914	FTG. 100F 3/4 FGD TEE-3 ENDS FEM PIP	1
144	057926	FTG, STRAIGHT THREAD CONNECTOR	4
145	057930	3/4 ML RUN TEE (FEM X ML X FEM PIPE)	2
146	064419	RUBBER INSERT SLEEVE 2 3/4" X 3" OD. (33027)	1
147	065188	AIR BONNET, FOR HATZ H50	1
148	065189	HATZ AIR CLEANER 4H50 BAND	1
149	065190	HATZ AIR CLEANER 4H50 BREATHER	1
150	065448	BATTERY BOX WELDMENT FOR TRTP TIER4	1
151	065454	BRACKET, COOLANT OVER FLOW BOTTLE MNT. HATZ TRTP	1
152	065460	END HANDLE, MOTOR END 255 TRTP (HATZ ENGINE)	1
153	065477	BRACKET, FUEL FILTER AND PUMP FOR HATZ FOR TRTF	1
154	065478	CONTROL BOX, FOR 255 TRTP WITH HATZ ENGINE	1
155	065482	WELDMENT, CONTROL BOX COVER FOR 255	1
156	065486	PUMP MOUNTING PLATE (HAYES043-0-HC4-91-B2) FOR HATZ ENGINE SAE "B" 2 BOLT	1
157	065487	CHANNEL, BRAETHER MNT TO FUEL TANK 255 WITH HATZ	1
158	065490	TRIPLE HYD PUMP F/ TRTP W/ HATZ	1
159	065495	REAR PLATE FOR PAN ASSEMBLE HATZ TRTP POWER END HANDLE TRTP	1
160	065497	PAN, BOTTOM WELDMENT FOR HATZ POWERED END HANDLE ASSEMBLY TRTP	1
161	065515	CONTROL PANEL, HATZ 85250208 FOR 255 trtp WITH Hatz Power	1
162	065517	NEOPRENE VIBRATION DAMPNER SANDWITCH MNT MALE/FEMAL 3/4" TALL 1" WIDE	4
163	065657	780 DECAL "OPERATOR'S MANUAL"	1
164	065848	BATTERY CABLE, NEGATIVE 2 AWG FOR HDX760/255 TRTP TIER4 HATZ	1
165	065849	BATTERY CABLE, POSITIVE 2AWG FOR TRTP TIER4 HATZ	1
166	065864	ENGINE ASSEMBLY, 255 HATZ GANG 255	1
167	065922	1/8 x 1/4 HOSE BARB	1
168	065950	WELDMENT, 255CD TANK WITH TIER 4	1
169	065991	ELBOW,90 DEGREE AIR INTAKE HATZ ENGINE	1
170	065993	CONNECTOR SLEEVE, HATZ ENGINE	1
171	066027	FLANGED SLEEVE BEARING HT AND OIL	2
172	066028	COOLANT RECOVERY BOTTLE F/ HATZ ENG.	1
173	066056	TOP HINGE, FOR HYD TANK 255T4 TRTP WITH HATZ	1
174	066057	TUBE, MOUNT F/STAND TRTF T4 HATZ	2
175	066058	BUSHING, F/HYD TANK TRTF T4 WITH HATZ	1
176	066059	WASHER RETAINER FOR DRIVE SHAFT ASSEMBLY TRACK DRIVE	1

Power End Assembly (cont'd) Parts List

SECTION 6 HATZ

ITEM	PART NO.	DESCRIPTION	QTY
177	066139	CLAMP, 2 1/4" MUFFLER	1
178	066186	HOSE, RIGID 2 3/4" I.D, INTAKE HATZ ENGINE CUT TO 6 1/4"	1
179	066255	MANUAL TUBE	1
180	066485	DECAL, FWD FINISH TUBE/UPSTEERING	1
181	066497	DECAL, FINISH TUBE VERTICAL ADJUSTER	1
182	066508	DECAL, WATER PUMP/OFF&ON	1
183	066515	DECAL, TRIPLE ROLLER TUBE PAVER 255	1
184	068806	FTG, HYDRAULIC FLANGE W46-16-16U	1
185	068807	FTG, 3/4 FLANGE KIT, W46-12-12U	1
186	069130		1
187	069138		1
188	069568		1
189	069569		1
190	069571		1
191	116008	U-BOLT CLAMP	4

INTENTIONALLY BLANK



AEC FACTORY & HEADQUARTERS

819 S. 5TH STREET
PARAGOULD, ARKANSAS 72450
870.236.7751
800.643.0095 (TOLL FREE (USA ONLY))

MAILING

PO BOX 819
PARAGOULD, ARKANSAS 72451

ALLENENG.COM

CONNECT WITH US ON SOCIAL

