

**TRIPLE ROLLER TUBE PAVERS**

# **TRTP265**

---



## **SAFETY & OPERATIONS MANUAL**

Manual Part #: 076279 | Revision: A  
Language: English | Original Instructions



**ALLEN**  
CONCRETE PAVERS

# *Triple Roller Tube Paver*

## **SAFETY & OPERATIONS MANUAL**

This manual covers the products listed below:

<u>Part No.</u>	<u>Description</u>
075449	ASSY, 265 12' TRTP WITH HATZ POWER
075450	ASSY, 265 14' TRTP WITH HATZ POWER
075451	ASSY, 265 16' TRTP WITH HATZ POWER
075452	ASSY, 265 18' TRTP WITH HATZ POWER
075453	ASSY, 265 20' TRTP WITH HATZ POWER
075454	ASSY, 265 22' TRTP WITH HATZ POWER
075455	ASSY, 265 24' TRTP WITH HATZ POWER
075456	ASSY, 265 26' TRTP WITH HATZ POWER
075457	ASSY, 265 28' TRTP WITH HATZ POWER
075458	ASSY, 265 30' TRTP WITH HATZ POWER
075459	ASSY, 265 32' TRTP WITH HATZ POWER
075460	ASSY, 265 34' TRTP WITH HATZ POWER

Copyright © 2022 Allen Engineering Corporation  
All rights reserved

All information, specifications, and illustrations in this manual are subject to change without notice and are based on the latest information at the time of publication. No part of this manual may be reproduced or transmitted in any form or by any means, electronic or mechanical, for any purpose, without the express written permission of Allen Engineering Corporation (AEC). AEC assumes no responsibility or liability for any errors or inaccuracies that may appear in this manual.

Allen Products are covered under one or more of the following patent numbers:

**U.S. Design Patents:** 6,857,815; 6955404; 7,108,449; 7,114,876; 7,316,523; 7,690,864; 8,360,680; 9,068,301; 10,100,537; 11,619,010.

Printed in U.S.A.

## Table of Contents

<b>Sect No.</b>	<b>Title</b>	<b>Page</b>
	<b>Table of Contents</b> .....	<b>3</b>
	<b>GENERAL INFORMATION</b> .....	<b>4</b>
	Limited Warranty.....	4
	Information Contained in this Manual .....	5
	Dealer Information .....	6
	Ordering Parts.....	7
	Model Number & Unit Identification.....	8
	Machine Dimensions.....	9
	Technical Specifications.....	10
	Engine Specifications .....	11
	Declaration of Conformity.....	12
	Declaration of Conformity, Hatz Engine .....	13
	Sound and Vibration Testing.....	14
<b>SECTION 1</b>	<b>SAFETY</b> .....	<b>16</b>
	Federal and State Regulations.....	17
	Safety Information.....	18
	Safety Symbols .....	19
	General Safety Information .....	20
	Service Safety .....	23
	Operational Safety.....	24
	Transportation Safety .....	25
	Lifting Safety .....	26
<b>SECTION 2</b>	<b>OPERATIONS</b> .....	<b>30</b>
	Pre-Operating Instructions.....	31
	Operator Controls .....	32
	Starting Instructions .....	33
	Engine Controls.....	34
	Gang Vibration Controls.....	35
	Vibration Amplitude Inspection .....	36
	Finish Tube Height Adjustment.....	37
	Tube Changing Procedure .....	38
<b>SECTION 3</b>	<b>SERVICE</b> .....	<b>42</b>
	TRTP Maintenance Schedule.....	43
	Oil and Filter Replacement .....	44
	Grease Tube Bearings .....	46
	Troubleshooting .....	47
	Cleaning Procedure.....	49
	Hydraulic Schematic for 32 to 34 ft.....	50
	Hydraulic Schematic for 18 to 30 ft.....	54
	Hydraulic Schematic for 12 to 16 ft.....	58
	Harness, 23' Gang TRTP Strobe Light .....	62
	Manual Revision Details .....	63

## GENERAL INFORMATION

## Limited Warranty

### I. LIMITED WARRANTY & LIMITATION OF LIABILITY

Allen Engineering Corporation (“Allen”) warrants its products to be free of defects in material or workmanship for:

**TWO YEARS FROM END USER’S DATE OF PURCHASE, SUBJECT TO THE EXCEPTIONS AND SHORTER WARRANTY PERIODS DESCRIBED HEREIN.**

**The warranty period begins on the date of purchase by the End User of the product. All warranty is based on the following limited warranty terms and conditions, including the disclaimer of all implied warranties of any type and the disclaimer of consequential damages.**



1. Allen’s obligation and liability under this warranty are limited to repairing or replacing parts if, after Allen’s inspection, there is determined to be a defect in material or workmanship. Allen reserves the choice to repair or replace.
2. All warranty-related parts must be purchased in advance through an Allen dealer. The parts will be made available to the Allen Distributor, Dealer, or Rental Center from whom the End User purchased the product.  
For machines being prepared, a warranty request form and/ or RGA request form must be submitted to AEC after the repairs are completed.
3. Replacement warranty parts, installed in the product, are warranted only for the remainder of the warranty period of the product as though they were the original parts.
4. BATTERY POWERED PRODUCTS ARE WARRANTED FOR ONE YEAR FROM END USER’S DATE OF PURCHASE.
5. Allen does not warranty engines or batteries. Engine warranty claims should be made directly to an authorized factory service center for the particular engine manufacturer. Batteries are not warranted due to unknown treatment during transport, etc., and any battery claims should be directed to the battery manufacturer.
6. Allen’s warranty does not cover the normal maintenance of products or their components(such as engine tune-ups and oil & filter changes). The warranty also does not cover normal wear and tear items(such as belts, tires, blades, pans and other consumables).
7. Hydraulic Component’s are required to be maintained per Allen’s mandatory service intervals in each machines owners manual. OEM Allen hydraulic filters and consumables are required to service machines during the warranty period. Failure to use OEM Allen hydraulic filters will result in denied warranty.
8. Allen’s warranty will be void if it is determined that the defect resulted from operator abuse, failure to perform normal maintenance on the product, modification to product, alterations, or repairs made to the product without the written approval of Allen. Allen specifically excludes from warranty any damage to any trowels resulting from a drop or impact to the rotors.
9. Impact damage to gearboxes is not covered under the Allen warranty and is deemed customer abuse.
10. Impact damage to trowels in any way is not covered under the Allen Warranty and is deemed customer abuse. ( Example: Dropping a machine)
11. Allen will pay shop labor on warranty items at the Allen Shop Labor Rate in existence on the date of the warranty claim. An Allen labor chart will determine the time allowed to complete a repair and will govern the shop labor hours that will be allowed.
12. Allen will credit the cost of ground freight on warranty replacement parts after approval of the warranty claim. No warranty replacement parts will be shipped air-freight at the expense of Allen. Allen does not pay any inbound freight.
13. ALLEN ENGINEERING CORPORATION’S WARRANTY POLICY WILL NOT COVER THE FOLLOWING: TAXES; SHOP SUPPLIES; ENVIRONMENTAL SURCHARGES; AIR FREIGHT; TRAVEL TIME;LOSS OF TIME;INCONVENIENCE;LOSS OF RENTAL REVENUE; RENTAL COSTS OF EQUIPMENT USED TO REPLACE THE PRODUCT BEING REPAIRED;LOSS OF USE OF THE PRODUCT; COMMERCIAL LOSS; OR ANY OTHER CHARGES WHATSOEVER OR ANY LIABILITIES FOR DIRECT, INCIDENTAL, OR CONSEQUENTIAL DAMAGE OR DELAY.
14. ALLEN ENGINEERING CORPORATION MAKES NO OTHER WARRANTY, EXPRESSED OR IMPLIED. THIS LIMITED WARRANTY IS IN LIEU OF THE WARRANTY OF MERCHANTABILITY AND FITNESS. THERE ARE NO OTHER WARRANTIES THAT EXTEND BEYOND THE DESCRIPTION ON THIS DOCUMENT.
15. No Allen employee or representative is authorized to change this warranty in any way or grant any other warranty unless such change is made in writing and signed by an officer of Allen Engineering Corporation.
16. Warranty claims must be submitted within 30 days from the date of failure.
17. Once a warranty claim has been submitted, AEC has up to 90 business days to process the request.
18. Standard service part warranty will not exceed 90 days from the date of purchase. Exceptions to this are:  
#1 Gearboxes: 1year warranty from date of purchase.  
#2 Electrical Components: 30 day warranty from date of purchase. This applies to wiring harnesses, transmitters, ECUs, display screens, and toggle switches.
19. All purchased components are subject to the inspection and warranty of the respective manufacturer. This inspection may extend beyond 90 days.
20. If warranty is suspected do not disassemble any hydraulic or electrical components. Failure to comply with this instruction will lead to denial of a warranty claim.



This manual provides information and procedures to safely operate and maintain the Allen Machine.

For your own safety and protection from personal injury, carefully read, understand, and observe the safety instructions described in this manual. Keep this manual or a copy of it with the machine at all times.

Always operate this machine in accordance with the instructions described in this manual. A well maintained piece of equipment will provide many years of trouble free operation.

This manual is divided into the following sections:

### SECTION 1 SAFETY

### SECTION 2 OPERATIONS

### SECTION 3 SERVICE

---

Complete any warranty requirements as specified by the engine manufacturer in their instructions found inside the manual box located on the operator's control panel.

Your engine is not manufactured by Allen Engineering Corporation, Inc, and therefore is not covered under Allen Engineering Corporation, Inc warranty.

Your engine manufacturer should be contacted if you wish to purchase a parts manual or a repair manual for your engine.

Refer to enclosed owners engine manual for complete O&M instructions. See your battery manufacturer for battery warranty.

# GENERAL INFORMATION

## Dealer Information

Your Dealer has Allen Engineering Corporation trained mechanics and original Allen replacement parts. Always contact the Allen Dealer who sold you this machine for Allen Certified repairs and replacement parts.

Place Allen Dealer information below for future reference.

Dealer Name: _____
Phone #: (____) - ____ - _____
Address: _____
City: _____ State: _____ Zip: _____
Salesman: _____ Mobile Phone _____
Additional Comments: _____
_____
_____

The PARTS Manual contains illustrated parts lists for help in ordering replacement parts for your machine. Follow the instructions below when ordering parts to insure prompt and accurate delivery:

1. All orders for service parts - include the serial number for the machine. Shipment will be delayed if this information is not available.
2. Include correct description and part number from the PARTS Manual.
3. Specify exact shipping instructions, including the preferred routing and complete destination address.
4. DO NOT return parts to AEC without receiving written authorization from AEC. All authorized returns must be shipped pre-paid.
5. When placing an order, please contact the AEC dealer nearest you.



All information, specifications, and illustrations in this manual are subject to change without notice and are based on the latest information at the time of publication.

## GENERAL INFORMATION

## Model Number & Unit Identification

### Manufacturer's Codes:

When ordering parts or requesting service information, you will always be asked to specify the model and serial numbers of the machine. The legends below specifically defines each significant character or group of characters of the Model Number and Serial Number codes.

**Model Number:** 265

### Serial Number

The serial number found on the identification plate is a ten digit format. The model number identifies your machine and will ensure that you receive the correct replacement parts.

### Serial Number Example

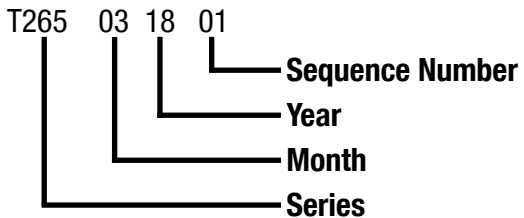

### Unit Identification Plate Location:

An identification plate listing the model number and the serial number is attached to each unit and is located on the top left corner of the operator end handle. See image below for serial number plate location. This plate should not be removed at any time.

Please record the information found on this plate below so it will be available should the identification plate become lost or damaged. When ordering parts or requesting service information, you will always be asked to specify the model and serial numbers of the machine.

### FILL IN FOR FUTURE REFERENCE

Model Number: \_\_\_\_\_

Serial Number: \_\_\_\_\_

Date Purchased: \_\_\_\_\_

Purchased From: \_\_\_\_\_

18' SETUP SHOWN

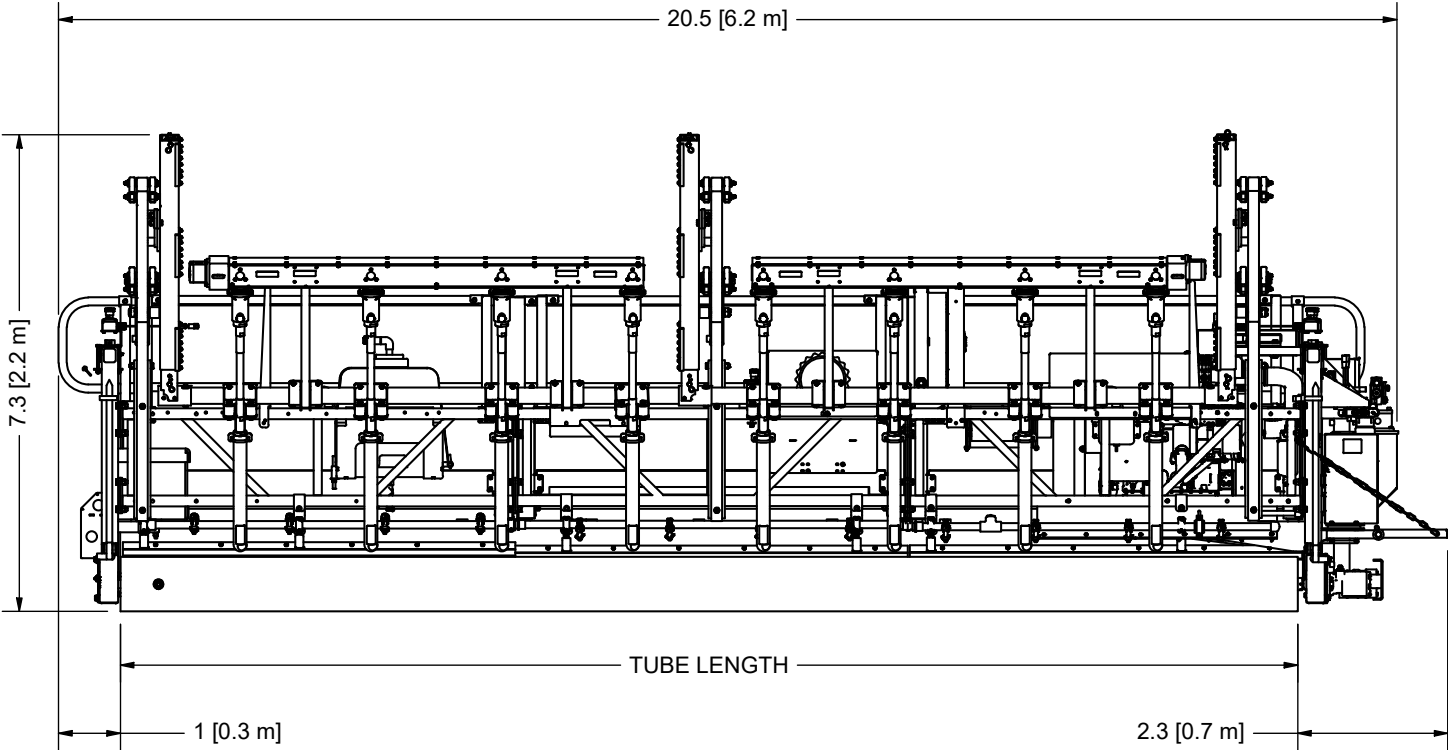

## GENERAL INFORMATION

## Technical Specifications

DESCRIPTION	TRTP265
ENGINE	HATZ 4H50TIC (T4F)
HORSEPOWER	74 HP (55.2 KW)
FUEL TYPE	DIESEL
WIDTHS AVAILABLE (2 FT INCREMENTS)*	12 - 34 FT (3.7-10.4 M)
WEIGHT AT 22 FT	8,700 LB (3,946 KG)
ROLLER TUBE DIAMETER	10 IN (25.4 CM)
TUBE WEIGHT PER FT	27 LB ( 12 KG)
FUEL TANK	10.4 GAL (39 L)
HYDRAULIC OIL TANK	30 GAL (114 L)
HYDRAULIC SPRAY SYSTEM	STANDARD
HYDRAULIC STEERING LEG	STANDARD
VIBRATOR DEPTH	24" BELOW GRADE
VIBRATOR FREQUENCY	11,000 VPM

\*NOTE: THE TRTP WILL NEED TO BE AT LEAST 2FT WIDER THAN THE PAVING WIDTH.

### FEATURES:

- Sectional frame length for ease of machine length change over.
- Ø10" Counter Ballast Tube
- 5 Emergency Stop Push Button Switches (2 at operator end, 2 on power unit end and in the 1 center rear of the machine)
- Strobe light

# Engine Specifications

## GENERAL INFORMATION

### HATZ 4H50TIC TECHNICAL DATA

TYPE	LIQUID COOLED 4 STROKE ENGINE
ENGINE OUTPUT (MAX)	73.8 HP
INJECTION SYSTEM	DIRECT INJECTION
BORE X STROKE	3.31 X 3.47 IN
DISPLACEMENT	119.12 CU IN
COMPRESSION RATIO	17.5:1
OIL CAPACITY	MAX - 7.4 QTS
	MIN - 6.3 QTS
LOWEST IDLE SPEED	900 RPM
ENGINE RPMS	1500, 1800, 2300, 2800 RPM
WEIGHT**	562 LB
DIMENSIONS** - L X W X H	35.2 X 27 X 31.8 IN

\*\* OPEN POWER UNIT MODEL

Crankcase breather filter

Oil filler

Oil dipstick

Engine oil filter

Fuel main filter

Poly-V-belt

Oil drain plug

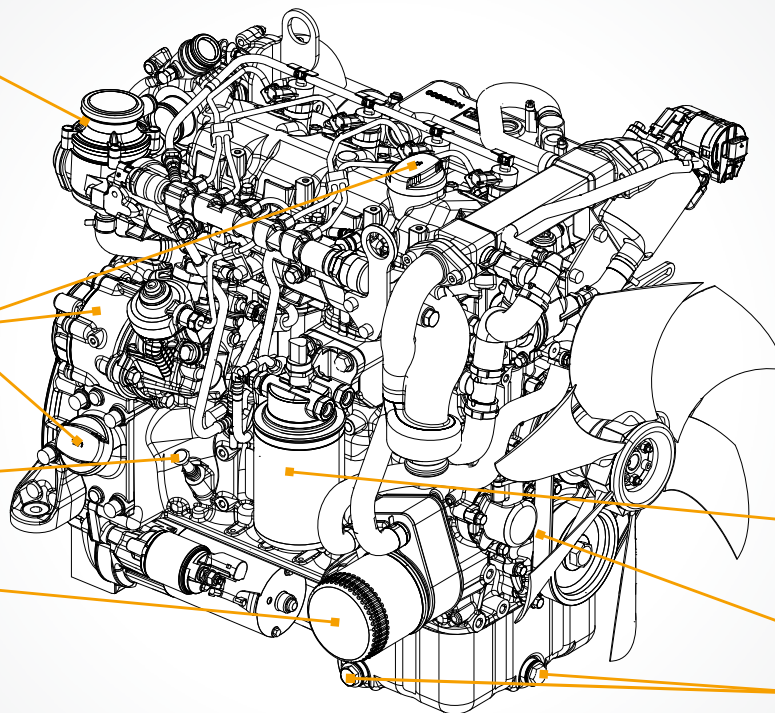

**PENDING INFORMATION**

### Extended Declaration of Incorporation EC Machinery Directive 2006/42/EC

The manufacturer: **Motorenfabrik Hatz GmbH & Co.KG**  
**Ernst-Hatz-Straße 16**  
**D-94099 Ruhstorf a. d. Rott**

hereby declares that the incomplete machine: product description: **Hatz diesel engine**

Type designation and as of serial number:

**3H50TIC = 13510, 3H50TI = 16310**

**4H50TIC = 13610, 4H50TI = 16110**

satisfies the following basic safety and health protection requirements in acc. with Annex I to the above-mentioned Directive.

- Annex I, General principles no. 1
- Nr. 1.1.2., 1.1.3., 1.1.5., 1.2.1., 1.2.2., 1.2.3., 1.2.4.1., 1.2.4.2., 1.3.1., 1.3.2., 1.3.3., 1.3.4., 1.3.7., 1.3.8.1., 1.4.1., 1.5.1., 1.5.2., 1.5.8., 1.5.9., 1.6.1., 1.6.2., 1.6.4., 1.7.

All relevant basic safety and health protection requirements down to the interfaces described

- in the manual for diesel engine
- in the enclosed data sheets
- in the enclosed technical documents

have been complied with.

The special technical documents in acc. with Annex VII B of the Directive 2006/42/EC have been prepared.

Conformity with the provisions of the following, other EC Directives, i.e.

- **2014/30/EU Electromagnetic Compatibility (EMC)**, dated 26.02.2014  
(was tested in association with a generator)

The following standards have been used (completely or partially):

- EN 1679-1: 092011                      - EN ISO 12100: 032011                      - EN ISO 13857: 062008
- EN 60204-1: 062007                      - EN ISO 13849-1: 062016

The manual for diesel engine has been enclosed to the incomplete machine and the Assembly Instructions have been provided to the customer electronically together with the order confirmation.

Commissioning has been prohibited until it has been established, if applicable, that the machine into which the above-mentioned incomplete machine is to be incorporated, satisfies the provisions of the Machinery Directive.

Wolfgang Krautloher / see "Manufacturer"  
Name / address of EC documentation officer

03.07.2017

Date

Krautloher / Directives official

Signature and information on the undersigned



Signature

**PENDING INFORMATION**

**PAGE LEFT BLANK INTENTIONALLY**

---

**SECTION 1**  
**SAFETY**

---

### Federal Respiratory Hazards

WARNING

#### SILICOSIS WARNING

Grinding/cutting/drilling of masonry, concrete, metal and other materials with silica in their composition may give off dust or mists containing crystalline silica. Silica is a basic component of sand, quartz, brick clay, granite and numerous other minerals and rocks. Repeated and/or substantial inhalation of airborne crystalline silica can cause serious or fatal respiratory diseases, including silicosis. In addition, California and some other authorities have listed respirable crystalline silica as a substance known to cause cancer. When cutting such materials, always follow the respiratory precautions mentioned above.



WARNING

#### RESPIRATORY HAZARDS

Grinding/cutting/drilling of masonry, concrete, metal and other materials can generate dust, mists and fumes containing chemicals known to cause serious or fatal injury or illness, such as respiratory disease, cancer, birth defects or other reproductive harm. If you are unfamiliar with the risks associated with the particular process and/or material being cut or the composition of the tool being used, review the material safety data sheet and/or consult your employer, the material manufacturer/supplier, governmental agencies such as OSHA and NIOSH and other sources on hazardous materials. California and some other authorities, for instance, have published lists of substances known to cause cancer, reproductive toxicity, or other harmful effects.

Control dust, mist and fumes at the source where possible. In this regard use good work practices and follow the recommendations of the manufacturers or suppliers, OSHA/NIOSH, and occupational and trade associations. Water should be used for dust suppression when wet cutting is feasible. When the hazards from inhalation of dust, mists and fumes cannot be eliminated, the operator and any bystanders should always wear a respirator approved by NIOSH/MSHA for the materials being used.

### Proposition 65 Warning

WARNING

#### CALIFORNIA — Proposition 65 Warning

Engine exhaust and some of its constituents, and some dust created by power sanding, sawing, grinding, drilling and other construction activities contains chemicals known to the State of California to cause cancer, birth defects and other reproductive harm. Some examples of these chemicals are:

- Lead from lead-based paints.
- Crystalline silica from bricks.
- Cement and other masonry products.
- Arsenic and chromium from chemically treated lumber.

Your risk from these exposures varies, depending on how often you do this type of work. To reduce your exposure to these chemicals: **ALWAYS** work in a well ventilated area, and work with approved safety equipment, such as dust masks that are specially designed to filter out microscopic particles.

## SECTION 1 SAFETY

## Safety Information

Do not operate or service the equipment before reading the entire manual. Safety precautions should be followed at all times when operating this equipment. Failure to read and understand the safety messages and operating instructions could result in injury to yourself and others.

### SAFETY NOTES

The four safety notes shown below will inform you about potential hazards that could injure you or others. The safety notes specifically address the level of exposure to the operator and are preceded by one of four words: DANGER, WARNING, CAUTION or NOTICE.



Indicates a hazardous situation which, if not avoided, **will** result in death or serious injury.



Indicates a hazardous situation which, if not avoided, **could** result in death or serious injury.









Indicates a hazardous situation which, if not avoided, could result in minor or moderate injury.



Addresses practices not related to personal injury.

Potential hazards associated with the operation of this equipment will be referenced with hazard symbols which may appear throughout this manual in conjunction with safety notes.

Symbol	Safety Hazard
	Lethal exhaust gas hazards
	Explosive fuel hazards
	Burn hazards
	Rotating parts/crush hazards
	Pressurized fluid hazards
	Hydraulic fluid hazards

## SECTION 1 SAFETY

### General Safety Information

- **NEVER** operate this equipment without proper protective clothing, shatterproof glasses, respiratory protection, hearing protection, steel-toed boots and other protective devices required by the job or city and state regulations.
- **NEVER** operate this equipment when not feeling well due to fatigue, illness or when under medication.
- **NEVER** operate this equipment under the influence of drugs or alcohol.
- **NEVER** use accessories or attachments that are not recommended by AEC for this equipment. Damage to the equipment and/or injury to user may result.
- **ALWAYS** avoid wearing jewelry or loose fitting clothes that may snag on the controls or moving parts as this can cause serious injury.
- **ALWAYS** know the location of the nearest fire extinguisher.
- **ALWAYS** know the location of the nearest first aid kit.
- **ALWAYS** clear the work area of any debris, tools, etc. that would constitute a hazard while the equipment is in operation.
- **ALWAYS** store equipment properly when it is not being used. Equipment should be stored in a clean, dry location out of the reach of children and unauthorized personnel.
- **DO NOT** use the equipment for any purpose other than its intended purposes or applications.
- No one other than the operator is to be in the working area when the equipment is in operation.
- This equipment should only be operated by trained and qualified personnel 18 years of age and older.
- Whenever necessary, replace nameplate, operation and safety decals when they become difficult to read.
- AEC does not assume responsibility for any accident due to equipment modifications. Unauthorized equipment modification will void all warranties.

- **ALWAYS** know the location of the nearest phone or keep a phone on the job site. Also, know the phone numbers of the nearest ambulance, doctor and fire department. This information will be invaluable in the case of an emergency.
- **ALWAYS** keep clear of rotating or moving parts while operating the paver.
- **NEVER** operate the equipment in an explosive atmosphere or near combustible materials. An explosion or fire could result
- **NEVER** disconnect any emergency or safety devices. These devices are intended for operator safety. Disconnection of these devices can cause severe injury, bodily harm or even death. Disconnection of any of these devices will void all warranties.
- **NEVER** operate the engine with heat shields or guards removed.
- **NEVER** run engine without an air filter or with a dirty air filter. Severe engine damage may occur. Service air filter frequently to prevent engine malfunction.
- **NEVER** tamper with the factory settings of the engine or engine governor. Damage to the engine or equipment can result if operating in speed ranges above the maximum allowable.



- Engine fuel exhaust gases contain poisonous carbon monoxide. This gas is colorless and odorless, and can cause death if inhaled.
- The engine of this equipment requires an adequate free flow of cooling air. Never operate this equipment in any enclosed or narrow area where free flow of the air is restricted. If the air flow is restricted it will cause injury to people and property and serious damage to the equipment or even causing severe bodily harm or even death.

## SECTION 1 SAFETY

## General Safety Information Continued

### **DANGER**

- **DO NOT** start the engine near spilled fuel or combustible fluids. Fuel is extremely flammable and its vapors can cause an explosion if ignited.
- **DO NOT** fill the fuel tank while the engine is running or hot.
- **DO NOT** overfill tank, since spilled fuel could ignite if it comes into contact with hot engine parts or sparks from the ignition system.
- **DO NOT** smoke around or near the equipment. Fire or explosion could result from fuel vapors or if fuel is spilled on a hot engine.
- **ALWAYS** refuel in a well-ventilated area, away from sparks and open flames.
- **ALWAYS** use extreme caution when working with flammable liquids.
- **NEVER** use fuel as a cleaning agent.
- Store fuel in appropriate containers, in well-ventilated areas and away from sparks and flames.

### **DANGER**

- **DO NOT** drop the battery. There is a possibility that the battery will explode.
- **DO NOT** expose the battery to open flames, sparks, cigarettes, etc. The battery contains combustible gases and liquids. If these gases and liquids come into contact with a flame or spark, an explosion could occur. The battery contains acids that can cause injury to the eyes and skin.
- **DO NOT** charge battery if frozen. Battery can explode. When frozen, warm the battery to at least 61°F (16°C).
- **ALWAYS** wear safety glasses when handling the battery to avoid eye irritation.
- **ALWAYS** keep the battery charged. If the battery is not charged, combustible gas will build up.
- Use well-insulated gloves when picking up the battery.

## NOTICE

Regular maintenance of the hydraulic system is important. These machines operate with high oil pressure. Minor damage or a crack in a hose or connection can have devastating consequences. Bear in mind that hydraulic hoses are made of rubber, which means that they age over time and that this can cause cracks to start forming. If there is the least doubt about the durability of hoses, or if damage is detected caused by mechanical wear, replace the hoses using genuine AEC hoses. Never store hoses for excessively long periods: hoses need to be used while still relatively new.

 **WARNING**

- **ALWAYS** keep the machine in proper running condition. Fix damage to machine and replace any broken parts immediately.
- **ALWAYS** disconnect the battery before servicing the equipment.
- **NEVER** lubricate components or attempt service on a running machine.
- **NEVER** touch the hot exhaust manifold, muffler or cylinder. Allow these parts to cool before servicing equipment.
- **DO NOT** place hands or fingers inside engine compartment when engine is running.
- **DO NOT** remove the engine oil drain plug while the engine is hot. Hot oil will gush out of the oil tank and severely scald any persons in the general area of the paver.
- **DO NOT** attempt to loosen or disconnect any hydraulic lines, hoses or fittings without first relieving hydraulic circuit pressure. Also, be careful not to touch any hydraulic components that have been in recent operation, because they can be extremely hot and can cause burns.

 **DANGER**

- If applicable, never use your hand to find hydraulic leaks. Use a piece of wood or cardboard. Hydraulic fluid injected into the skin must be treated by a knowledgeable physician immediately or severe injury or death can occur.

## SECTION 1 SAFETY

# Operational Safety

Before starting up and during operation of the paver, the operator must make sure that there are no persons in the “danger zone”. All persons that are in the vicinity of the paver must be informed of the dangers that can result from the operation of the paver.

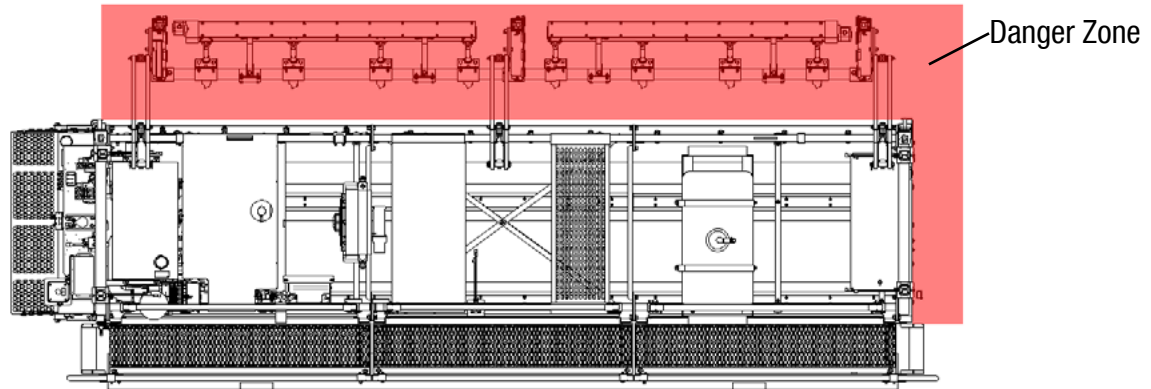

- Only mount or dismount the machine while the machine is stationary. Use the handles and retaining fixtures provided.
- The operator must look in the direction of travel and must always have a clear view of the route ahead. Especially when operating in the reverse direction, he must ensure that his path and the working area are clear.
- Do not attempt to operate the paver unless fully trained in the machine operation, only authorized personnel should operate the paver. All instructions provided in this manual and on the machine operating and warning decals must be followed to prevent damage to the equipment and/or injury to operating personnel.
- Check paver for proper functioning of controls before operating. Observe all gauges and instruments, and correct any malfunctions before operating.
- Always wear personal protective equipment (PPE) appropriate for the job and working conditions. Hard hats, safety glasses, protective shoes, gloves, reflective vests, respirators and ear protection are examples of types of equipment that may be required. Do not wear loose-fitting clothing, long hair, jewelry or loose personal items while operating or servicing the paver.
- Always check the job site for obstructions and bystanders.
- Always perform a daily inspection of the paver before using it. Look for damage, loose or missing parts, leaks, etc.
- Walk around the paver and warn all nearby personnel before starting the paver.
- Pressing the **emergency stop button** (e.g. when someone enters the danger zone, when the machine is no longer under control, etc.) causes the drive motors, the screed motor and the steering system to be switched off. The paver brakes to a standstill. Before the paver can be started up again, the cause of the malfunction must be determined and the malfunction eliminated. The machine must then be started up again as described in the Starting Instructions.

Before driving, make sure your vehicle maintenance and trailer maintenance are current. This is very important because towing puts additional stress on the tow vehicle.

- Check and correct tire pressure on the tow vehicle and trailer, including the spare tire.
- Make sure the wheel lug nuts/bolts on the tow vehicle and trailer are tightened to the correct torque.
- Be sure the hitch, coupler, draw bar and other equipment that connect the trailer and the tow vehicle are properly secured and adjusted.
- Make sure the safety chains are properly criss-crossed and connected, not touching the road but with enough slack to make turns.
- Check that the wiring is properly connected; not touching the road, but loose enough to make turns without disconnecting or damaging the wires.
- Make sure all running lights, brake lights, turn signals and hazard lights are working.
- Verify that the brakes on the tow vehicle and trailer are operating correctly.
- Ensure the breakaway system lanyard is connected to the tow vehicle but not to the safety chains or ball mount.
- Be sure the trailer jack, tongue support and any attached stabilizers are raised and locked in place.
- Check load distribution to make sure the tow vehicle and trailer are properly balanced front to back and side to side.
- Check side and rear-view mirrors to make sure you have good visibility.
- Check routes and restrictions on bridges and tunnels.
- Make sure you have wheel chocks and jack stands.
- Match the maximum trailer weight allowed for the tow vehicle to the GVWR of the trailer.
- Match the hitch weight carrying capacity of the tow vehicle with the loaded tongue weight of the trailer. This is generally 10% of GVWR on tag models and 20% of GVWR on 5th wheels and Goosenecks. Tag models may require a weight distributing hitch with sway controls. Contact your hitch specialist to properly set up your tow vehicle/trailer combination.
- Match the size of the brake controller to the number of braking wheels on your trailer. These are sold usually as 2 to 4 wheel brake or 2 to 6 wheel brake units. For proper controller adjustment, see your brake controller manual.
- Match the wiring of the tow vehicle to the wiring code on the trailer. Ensure your tow vehicle does have a ground wire running from the receptacle to the frame.
- Match the ball size to the coupler size.
- Match your Fifth Wheel or Gooseneck trailer to a correct and compatible hitch provided by your hitch specialist. Then consult your hitch specialist for proper maintenance of the hitch assembly.
- Match your rear vehicle suspension to the loaded hitch weight of the rear axle of the tow vehicle. All marginal situations should be corrected for safe trailering. Remember, you are the one that will be trying to control a large combination of weight and size at high speeds. It is your responsibility to set up tow vehicle/trailer properly. Contact or confirm your set up with a local hitch company professional.

## **SECTION 1 SAFETY**

### **Lifting Safety**

#### **Safe systems of work**

The following safe systems of work must be in place prior to carrying out any lifting operation.

- Pre-site inspection – Ground stability conditions / access / egress, weather conditions etc.
- Suitable cranes – Lifting accessories.
- Pre-Inspection of the lifting equipment / testing / examination / certification.
- Risk assessment / method statement.
- Lift plan.

Before lifting heavy loads, reference relevant lifting codes and standards. i.e. BS 7121

#### **Requirements for lifting equipment**

The employer shall ensure that lifting equipment provided for use at work is safe, i.e. that it is:

- Sufficiently strong, stable and suitable for the proposed use.
- Positioned or installed to prevent the risk of injury, e.g. from the equipment or the load falling or striking people
- Visibly marked with any appropriate information to be taken into account for its safe use, e.g. safe working loads. Accessories, e.g. slings, clamps etc., should be similarly marked
- Where equipment is used for lifting people it is marked accordingly, and it should be safe for such a purpose, e.g. all necessary precautions have been taken to eliminate or reduce any risk.

OSHA has set forth guidelines which detail the use of Rigging Equipment for Material handling. This guideline is found under

**OSHA Standard Number: 1926.251**

Please read and follow all guidelines found in this standard.

Removal from service.

**Synthetic web slings shall be immediately removed from service if any of the following conditions are present:**

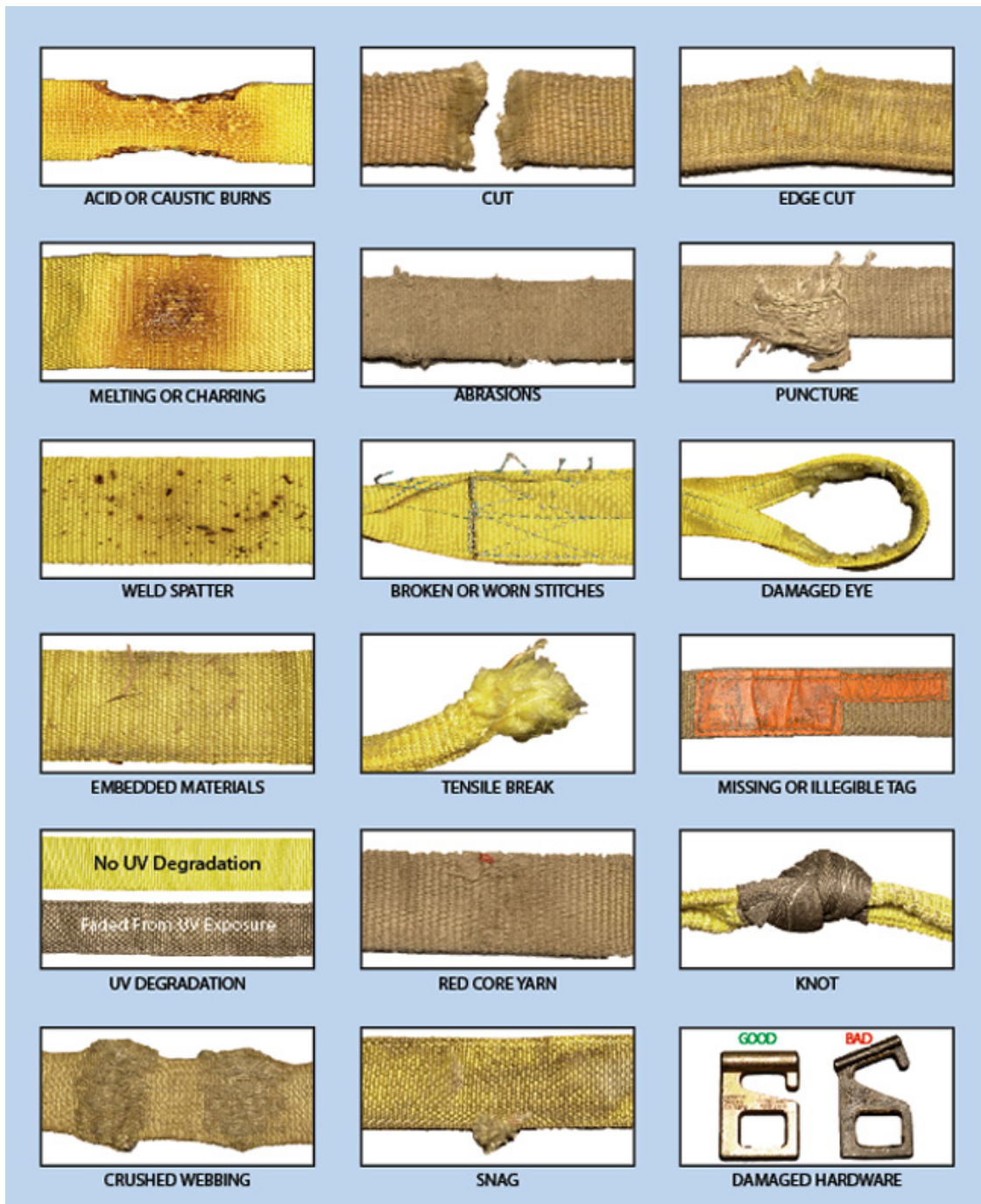

## SECTION 1 SAFETY

### Lifting Safety

#### When Lifting the TRTP:

- Always lift the machine using the **lifting lugs** [4 per machine], see the figures below
- Always check the sling angle, preferably ensure that the sling angle is as close to 90° as possible, or preferably no less than 60°
- Always ensure that the lifting components are of sufficient load bearing capacity
- Never use damaged slings or ropes
- Avoid sharp bends, pinching and crushing the sling
- Make sure that the areas underneath and around the load are clear at all times

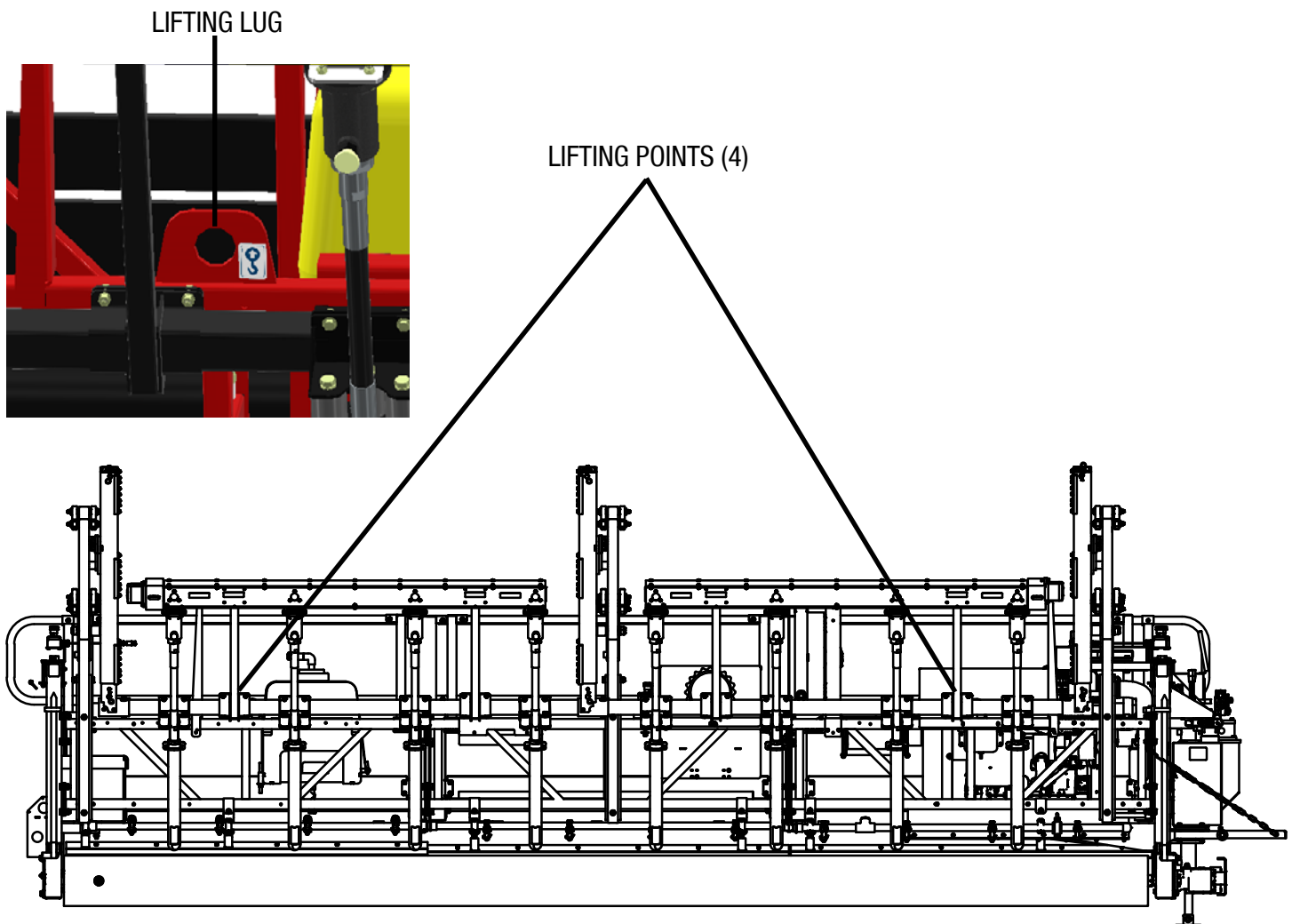

### Use of Shackles and Hooks

#### Lifting Hooks:

Inspect hooks daily before use and frequently during use. Remove a hook from service when any of the following conditions exist:

- Missing or illegible manufacturer identification
- Cracks, nicks, or gouges
- Damage from heat
- Unauthorized repairs
- Improper operation and locking of self-locking hooks
- Any Distortion or wear on hook



#### Lifting Shackles:

Inspect shackles daily before use and frequently during use.

- Excessive pitting or corrosion
- Body spread including: bent, twisted, distorted, stretched, elongated, cracked, or broken load bearing components
- Excessive nicks or gouges
- incomplete pin engagement, shoulder of pin is not flush with shackle body
- Excessive thread damage



#### NOTICE

The rated capacity of shackles only applies when they are symmetrically loaded and the included angle between two sling legs is a maximum of 120°. Shackle capacity must be reduced when the angle is greater than 120°.

Never allow the shackle to be pulled at an angle

---

**SECTION 2**  
**OPERATIONS**

---

**Before operation each day ensure the following:**

- All guards, side screens and panels are in place.
- All safety and information signs are in place and legible.
- Engine and hydraulic oil levels are correct.
- Check battery level
- Check for hydraulic leaks.
- Check all operating controls for proper operation and adjustment.
- Check speed control operation before and after starting engine for proper operation.
- Remove loose objects that could interfere with operation.

**Note:** If there is any indication that faulty equipment exists, shutdown safely, inform the proper authority and **DO NOT** operate the paver until the problem has been fixed.

# SECTION 2 OPERATIONS

## Operator Controls

Shown below is the layout of the operator controls:

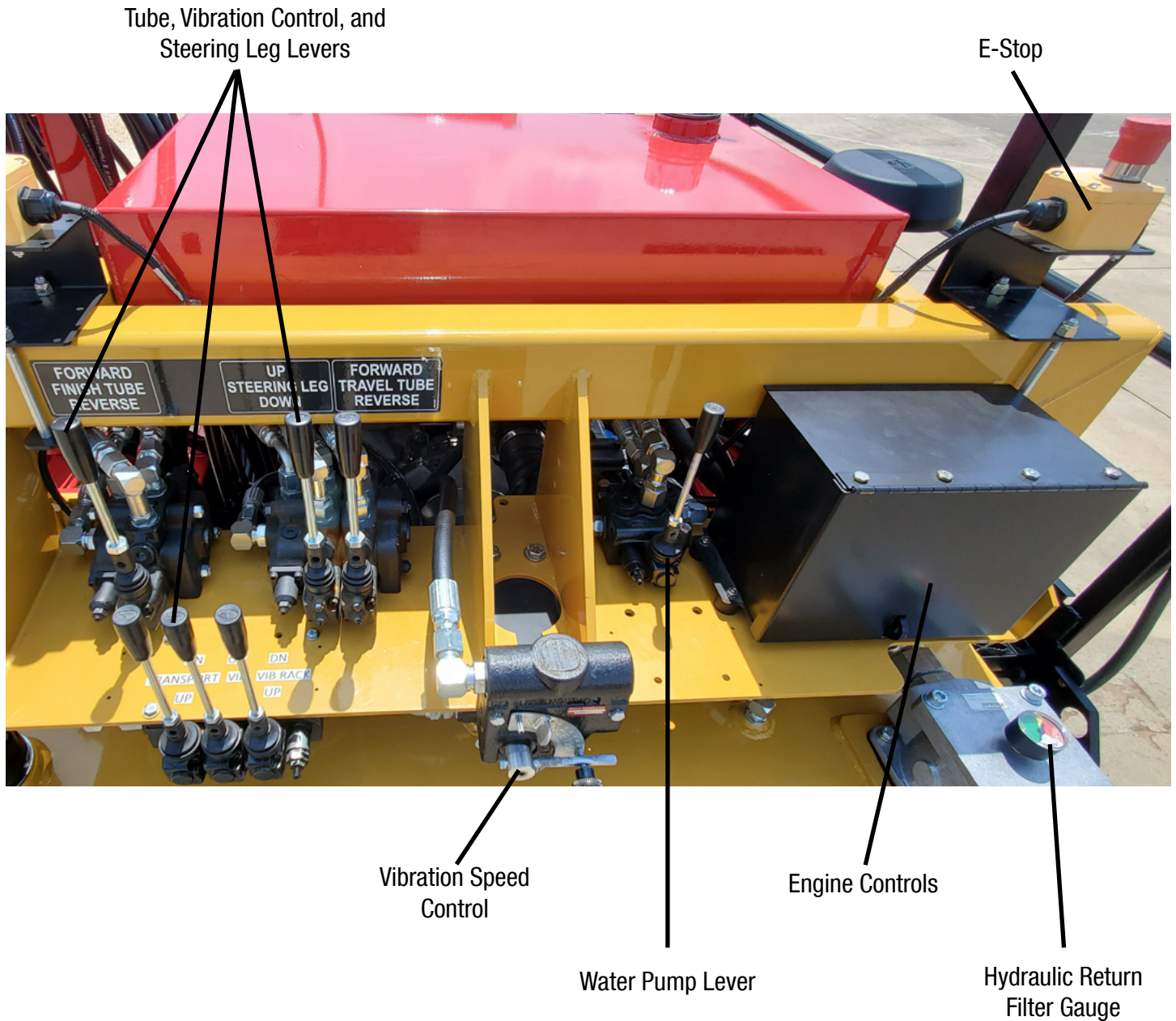

### Starting the Engine

NOTE: If temperature is below 0°C (32°F), it may be necessary to use cold weather starting aids.

1. Perform all pre operation instructions outlined page 31
2. Ensure that the controls are in the OFF or NEUTRAL position before starting the Paver.
3. Turn the ignition switch to the RUN or I position before fully starting the engine

The ignition switch is a three position start switch. Where “0” is the OFF position, “I” is the operation or RUN position, and “II” is the start or CRANK position.

- To start the engine turn the switch clockwise to the “I” position, indicators will light up.
- Wait until the Engine Pre-glow Indicator light turns off (a horizontal curl), then turn the key start switch clockwise “II” position to crank the engine.
- When the engine starts, release the key switch so that it returns to the “I” position.

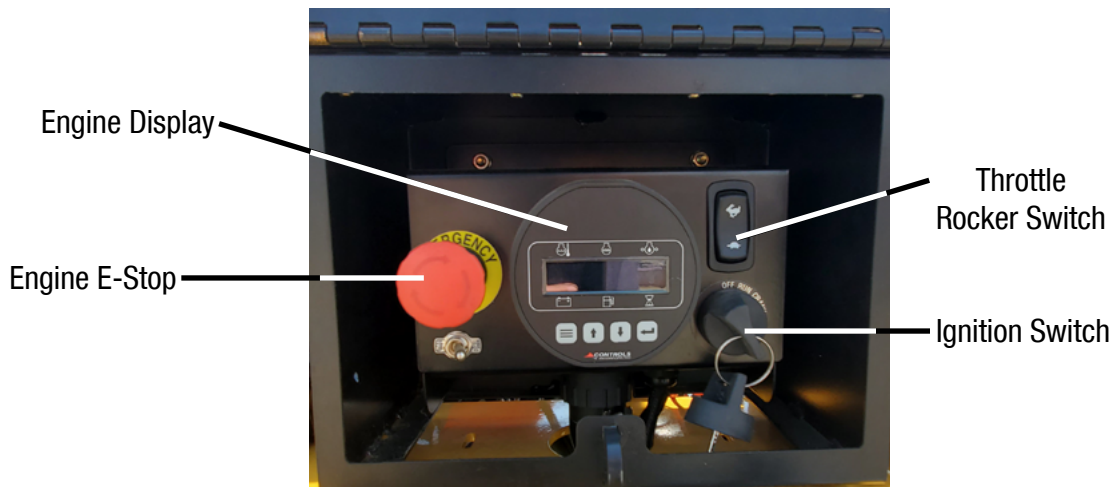

**Do not operate the starter for more than 20 SECONDS at a time.** To do so may overheat the starter. If the engine does not start the first time, wait at least 2 minutes before trying again. If engine does not start see the Troubleshooting section in this manual and the OEM manual.

**If the key switch is released before the engine starts, wait until the starter and the engine stop turning before trying again. This will prevent possible damage to the starter and/or flywheel.**

4. Set the engine speed by using the rocker switch,
  - For slow speed, press the lower half of rocker switch (indicated by turtle symbol)
  - For fast speed, press the upper half of rocker switch (indicated by rabbit symbol)
5. After engine starts, idle engine at a low RPM until warm.

### **Stopping the Engine**

1. Stop the machine and return the movement controls to their neutral position.
2. Set the Speed Select Rocker Switch to low idle
3. Run engine at a reduced speed and load for at least 5 minutes to cool.
4. Turn ignition switch to “0” or Off position to stop the engine.

### **Restarting Engine After Emergency Shutdown**

In the event of an emergency engine shutdown, the following procedures are required to restart the engine.

1. Correct the condition causing the emergency shutdown
2. Perform relevant Pre-Start procedures, return all switches to their neutral position, and set the engine speed to slow.

For ALL emergency shutdowns, the controller must be reset before the engine can be restarted. Recycle the key switch to reset the controller.

3. Recycle the key start switch (F) as follows:
  - a. Turn ignition switch off.
  - b. Wait 15 seconds.
  - c. Turn ignition switch clockwise to the “1” or operation position, when the pre-glow indicator goes out start the engine.
4. Before operating the paver let the engine run at a no more than 1200 RPM, and check all displays and for normal engine operation.

### Vibration Controls

There are three levers to control the vibration rack. Reference the Figure: Vibration Controls (Decal) below.

- Vibrator Rack Lever A: Controls the extension and retraction of the vibration racks
- Vibration Lever B: Turns the vibrators on and off
- Vibration Lever C: Raises and Lowers the vibrators

### Vibrator Operation

1. Start the engine normally as described on page 33.
2. Bring the engine to Full Operating RPM.
3. Use the Vibration Rack DN/UP lever to lower the vibrators into the concrete and raise them out.
4. Use the Vibrator ON/OFF lever to turn the vibrators “on” when entering concrete and “off” when exiting concrete.



Leaving the vibrators on out of concrete for more than 3 minutes can cause internal damage due to overheating.

5. Use the Vibrator Speed Control to control the amount of VPM's into the concrete

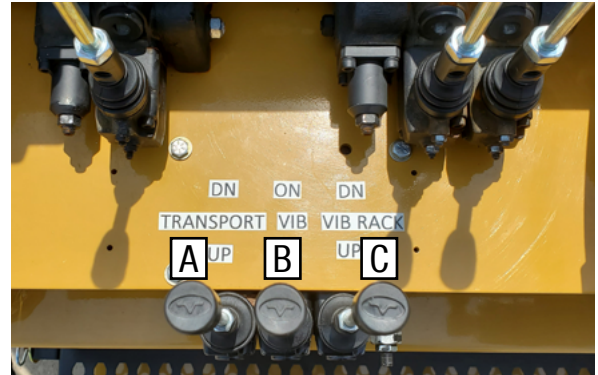

Vibration Control Levers

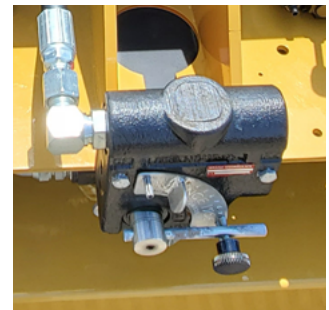

Vibration Speed Control

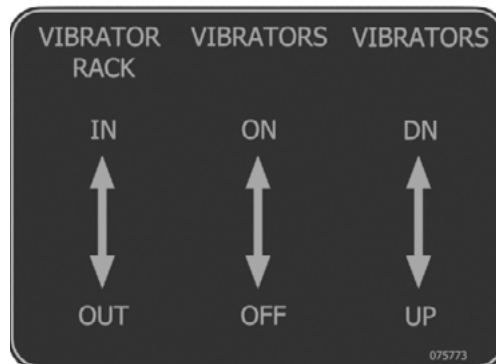

Figure: Vibration Controls (Decal)

### NOTICE

It is not uncommon for a pendulum type vibrator head to fail to vibrate when the motor is switched on or started. If the vibrating head does not start vibrating immediately, tap the tip of the vibrator head sharply with a rubber mallet.

## SECTION 2 OPERATIONS

# Vibration Amplitude Inspection

To check the amplitude of the vibration, follow the directions below:

- Attach the optical wedge decal to the barrel of the vibrator as close to the nose as possible
- Hang vibrator vertically in the air
- Run vibrator and observe the optical wedge  
(The image on the wedge will change with the pointed end of the wedge become pale and appearing to visually move up the scale)
- Touch optical wedge with a pen where wedge image turns from pale to dark. Stop vibrator and note the measurement
- The measurement will reflect the full wave amplitude in inches

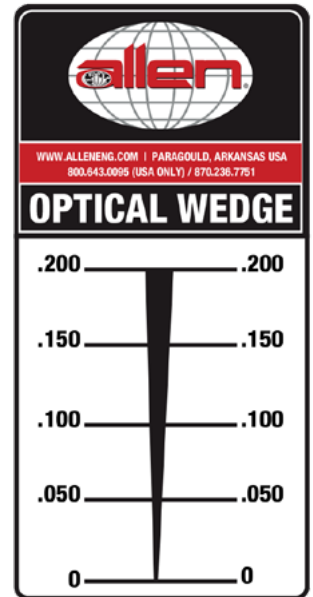

### Finish Tube Height Adjustment

To raise or lower the front finish tube do the following:

- Remove the tube adjustment lock(A) from the end handle. Fastened by 1/4" bolt.
- To raise the tube, turn the adjustment nut (1-1/2") (B) in a clockwise rotation.
- To lower the tube, turn the adjustment nut (B) counter-clockwise.

NOTE: The factory sets this tube at 1/8" above grade. There is a scribe line on the motor and idle end handles at the point where the tube is set. See Fig 2.3.4

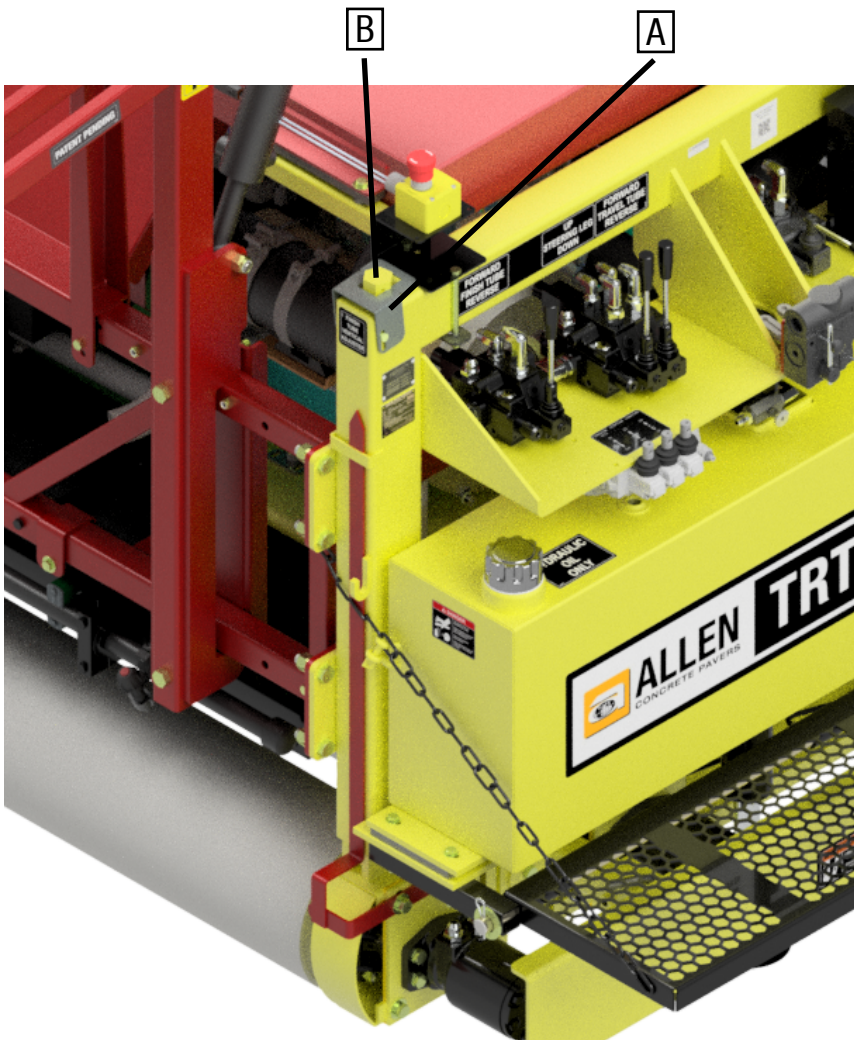

## SECTION 2 OPERATIONS

### Tube Changing Procedure

Idle End

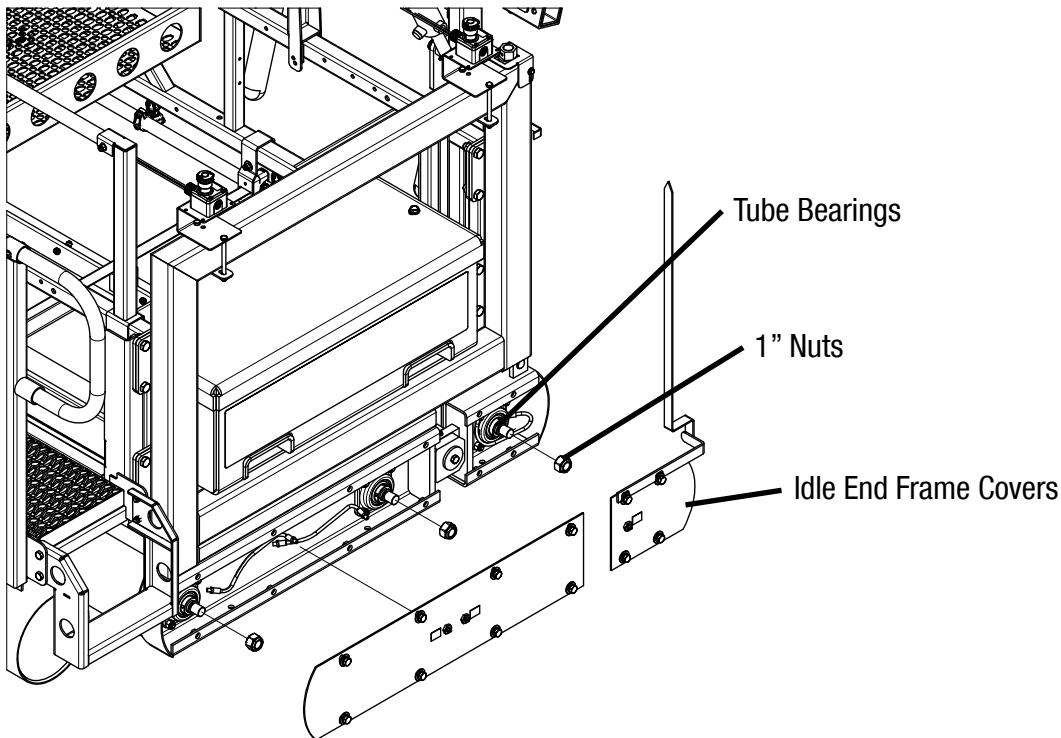

#### To Remove the Tubes - Idle End:

1. Remove the cover off of the idle end frame. Fastened by 12 HHCS 1/2"-13 X 1".

**NOTE:** There are grease lines attached to the end frame covers and bearings, if necessary unfasten the grease lines.

2. Take the 1" nuts off of the idle end tube shafts.
3. Loosen the set screws on bearings
4. Then take the 16 bolts off the idle end frame that connect the framework to the end frame to remove the idle end frame. See page 40.



**NOTE:** Make sure that the framework is supported by a crane to insure that the framework does not collapse. **Please see additional note on pg 39**

5. See page 39 for the motor end steps

Motor End

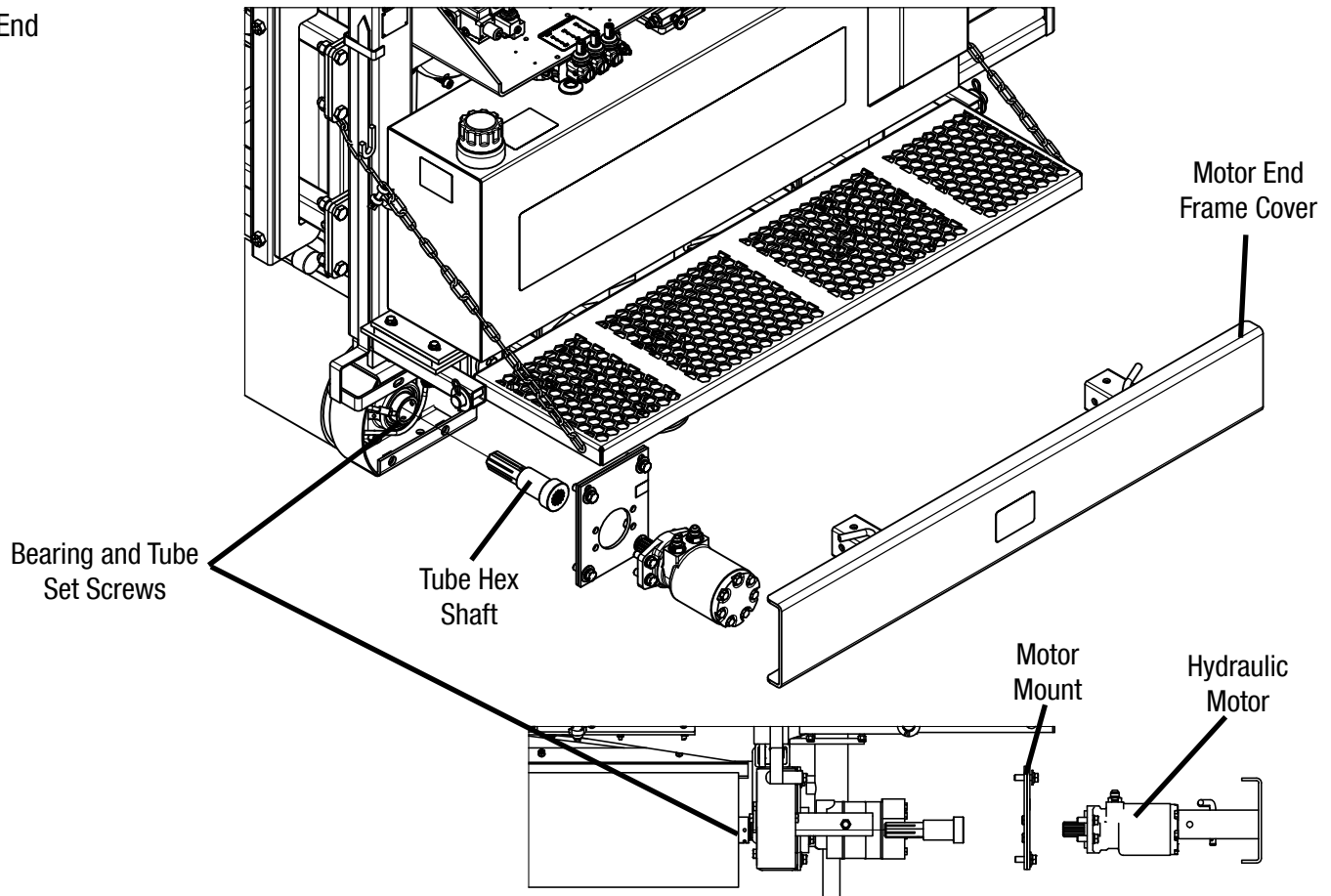

### To Remove the Tubes - Motor End:

1. Remove the cover off of the motor end frame. Fastened by 2 pins.
2. Unfasten the hydraulic motors (3). Fastened by (4) 1/2" bolts. If necessary remove the motor mounting plates. Fastened by (4) 1/2" bolts
3. Loosen the set screws on the bearings and the tube connection.
4. If only the tubes need to be changed at this point the tubes can be removed. Tube removal may be easier if the motor end frame is removed, follow step 4 on pg 38.

### NOTICE

**Removing the End Frames and Frame Sections will affect the Hydraulic Hoses, Electrical Wiring, and the Vibration Racks. Contact Customer Service for help, 870.236.7751 EXT. 3**

## SECTION 2 OPERATIONS

### Tube Changing Procedure

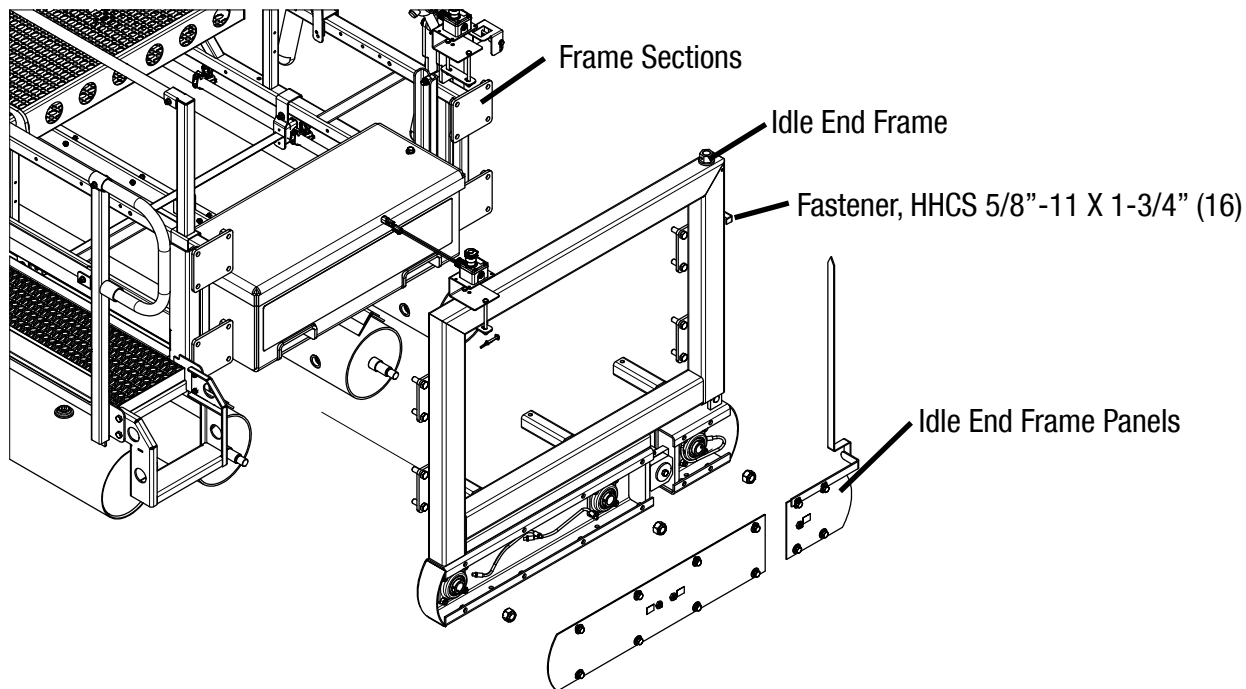

#### To change the frame sections:

1. Complete the steps 1-3 on page 38 and 39.
2. Take the 16 bolts off the end frames that connect the framework to the end frames.



**NOTE:** Make sure that the framework is supported by a crane to insure that the framework does not collapse.

3. Remove the idle and motor end frames.
4. Using the same method as in step 1, take the framework apart or add to section by section until the desired length is achieved.

#### NOTICE

**Removing the End Frames and Frame Sections will affect the Hydraulic Hoses, Electrical Wiring, and the Vibration Racks. Contact Customer Service for help, 870.236.7751 EXT. 3**

**PAGE LEFT BLANK INTENTIONALLY**

---

**SECTION 3**  
**SERVICE**

---

SERVICE CHECKLIST				
TASK	DAILY	EVERY 20 HRS	EVERY 50 HRS	EVERY 500 HRS
Inspect				
Check external hardware	✓			
Check hoses & fittings for leaks	✓			
Check fuel, engine oil, hydraulic oil levels	✓			
Check the cooling systems (hydraulic & engine) for blockage on radiator, wear, leaks	✓			
Check air and hydraulic filters	✓			
Check steering leg for corrosion, pitting or wear			✓	
Check hydraulic motors for normal operation, abnormal temps. or noise			✓	
Action				
Grease tube bearing (See pg 46)		✓		
Change engine oil*				✓
Change engine oil filter				✓
Change fuel filters				✓
Change hydraulic fluid**				✓

\* SEE HATZ ENGINE OWNERS MANUAL FOR DETAILED SERVICE INSTRUCTIONS

\*\* As a precaution the hydraulic fluid should be changed annually, the fluid should be checked regularly for contamination and/or tested for the right chemical makeup.

## SECTION 3 SERVICE

# Oil and Filter Replacement

### Engine Oil

Oil Quality, Use oil that follows at least one of the specifications listed below. (Oil Capacity 6.3-7.4 QTS, see pg 11)

- ACEA E6
- ACEA E9
- ACEA C3/C4 (HTHS  $\geq$  3.5 MPAS)
- API CJ-4

Use the graph below to select oil viscosity based on the ambient temperature.

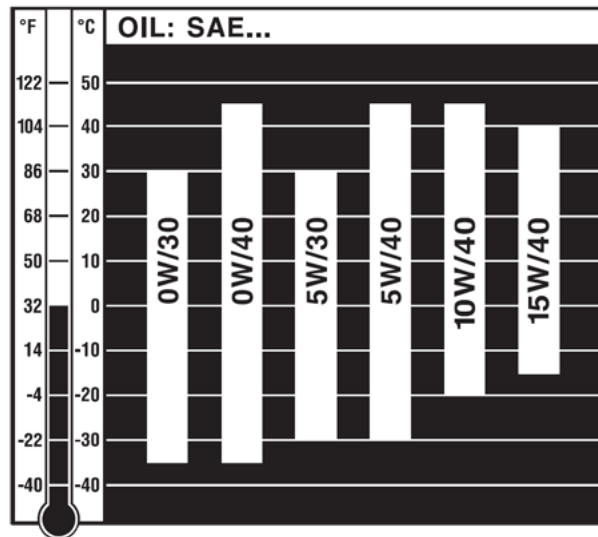

### Engine Oil

- Change the type of engine oil according to the ambient temperature.
- When using oil of different brands from the previous one, be sure to drain all the previous oil before adding the new engine oil.
- For general use 15W/40 oil is recommended (6.3 Qts or up to ~7.4 Qts). Ensure that the engine oil meets Hatz engine oil specifications

### Hydraulic Oil

Replace hydraulic fluid with Hydraulic oil 46 (DTE 25) or equivalent, 30 GAL (114 L) tank.

#### **HYDRAULIC FILTERS:**

- TMF-10-5, 1-1/4" x 0.75" [(4) Hyd. tank outlet filters]
- TMF-25-5, 2" x 1.25" [(1) Hyd. tank outlet filter]
- TMF-05-5 PART NUMBER: 049358 [(1) Hyd. tank return line filter]

### Service Replacement Parts

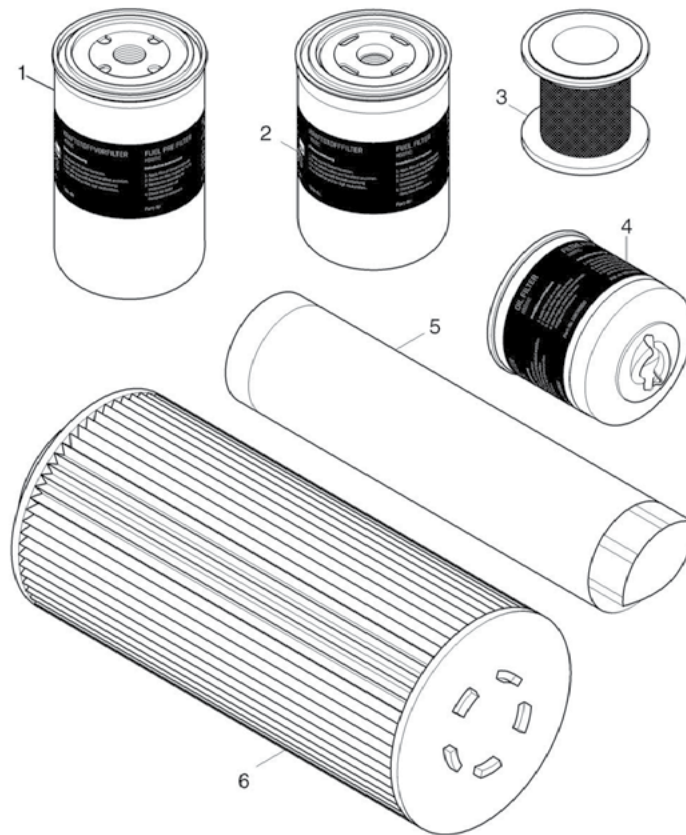

Replacement Filters			
Item	Part #	Description	Qty
1	065851	Pre-Fuel Filter	1
2	065852	Fuel Filter	1
3	065853	Oil Separator	1
4	065854	Oil Filter	1
5	065855	Air Filter - Secondary	1
6	065856	Air Filter - Primary	1

# SECTION 3 SERVICE

## Grease Tube Bearings

MOTOR END

\*Parts Removed for Clarity

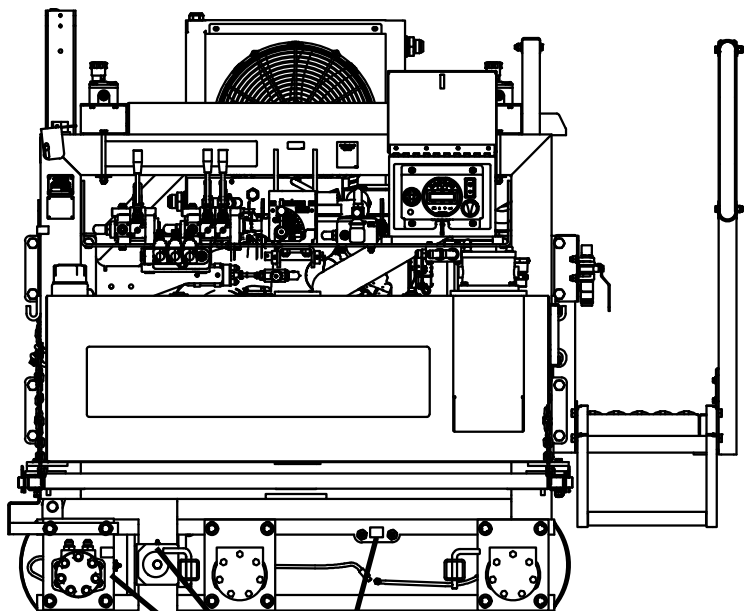

GREASE POINTS (APPROXIMATELY EVERY 20HRS)

IDLE END

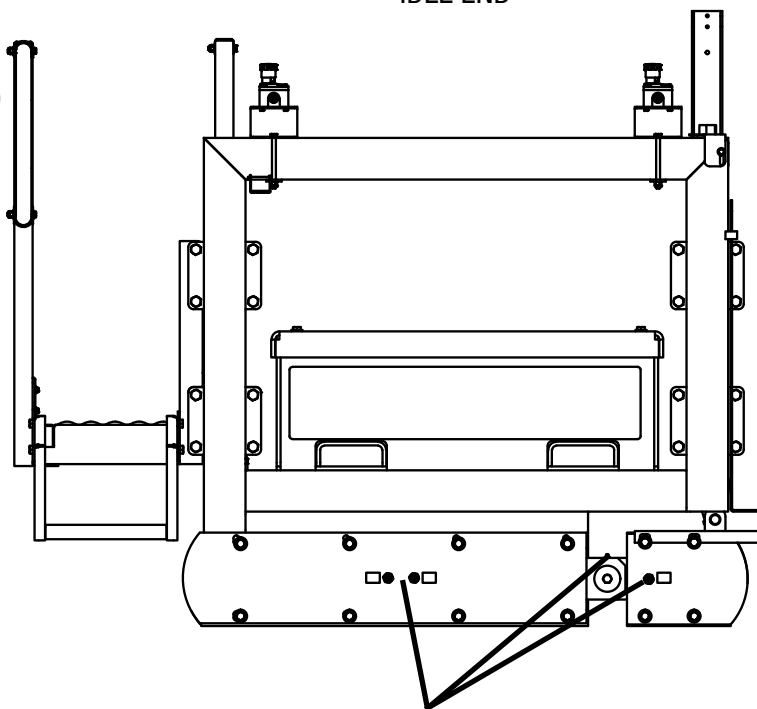

GREASE POINTS (APPROXIMATELY EVERY 20HRS)

Area	Malfunction	Possible Cause	Corrective Measure	Ref.
Engine	Engine does not start, or is difficult to start	Battery is discharged	- Add battery fluid - Charge the battery - Replace the battery	
		Battery cable is disconnected	- Connect battery cable	
		Blown fuse	- Replace fuse	
		Bad connection or breakage in the wiring	- Contact your AEC dealer	
		Out of fuel	- Fill fuel	
		Air is in fuel	- Contact your AEC dealer	
		Engine fouled	- Wait a while and try starting again	
		Insufficient or wrong oil	- Fill or change oil	
		Dirty or damaged spark plug	- Clean or replace spark plug	
		Contamination in fuel system	- Contact your AEC dealer	
		Other (other than above)	- Contact your AEC dealer	
	Engine stalls	Out of fuel	- Fill fuel	
		Cold engine	- Warm up the engine	
		Other (other than above)	- Contact your AEC dealer	
	Engine stops abruptly	Out of fuel	- Fill fuel	
		Piston seizure due to insufficient or bad oil	- Contact your AEC dealer	
		Other (other than above)	- Contact your AEC dealer	
	Engine does not stop	Electrical malfunction	- Contact your AEC dealer	
		Other (other than above)	- Contact your AEC dealer	
	Idling is not stable	Insufficient intake air (clogged air cleaner)	- Clean or replace the air cleaner	
		Other (other than above)	- Contact your AEC dealer	
	Poor power or acceleration	Bad fuel	- Change fuel	
		Wrong oil (improper viscosity)	- Change to suitable oil	
		Accelerator (throttle) is not properly adjusted	- Contact your AEC dealer	
		Insufficient intake air (clogged air cleaner)	- Clean or replace the air cleaner	
		Excessive load	- Reduce load	
		Loose drive belt	- Adjust	
	Irregular noise or vibration from or around the engine		- Contact your AEC dealer	
			- Contact your AEC dealer	
	Excessive oil consumption		- Contact your AEC dealer	
	Engine overheats	Insufficient amount of engine oil	- Fill oil	
		Cooling fan is clogged or blocked	- Clean	
		Other (other than above)	- Contact your AEC dealer	
Excessive fuel consumption	Clogged air cleaner	- Clean or replace air cleaner		
	Other (other than above)	- Contact your AEC dealer		

## SECTION 3 SERVICE

## Troubleshooting Continued

Area	Malfunction	Possible Cause	Corrective Measure	Ref.
Engine	Black smoke comes out of exhaust	Bad fuel	- Change fuel	
		Clogged air cleaner	- Clean or replace the air cleaner	
		Choke is not fully open	- Open the choke fully	
		Other (other than above)	- Contact your AEC dealer	
	White or blue smoke comes out of exhaust	Engine oil level is too high	- Adjust the oil level	
	Other (other than above)	- Contact your AEC dealer		
Safety Devices	Lamp does not light	Blown bulb	- Replace	
		Blown fuse	- Replace	
			-Check light electrical plug, make sure it plugged in the right orientation.	
Other (other than above)	- Contact your AEC dealer			
Hydraulic System	Pump does not work	Insufficient or deteriorated hydraulic fluid	- Add or change fluid	
		Other (other than above)	- Contact your AEC dealer	

## Machine Cleaning Procedure

When cleaning the machine, please adhere to the following information to ensure proper cleaning and to keep the machine in the best condition possible.

### Power Washing Procedure:

#### NOTICE

- Ensure that the water pressure is below 2000 PSI (14 MPa)
- Always keep the water temperature below 180°F (80°C)
- Use a spray nozzle with at minimum 40° wide spray angle
- Keep the nozzle at least 1 foot (300mm) away from the machine
- Avoid spraying water on the engine and electronic components. Examples include electronic displays, lights, switches, wiring, etc. The electronic components may be damaged if water is sprayed on them.
- Keep a perpendicular angle (90°) when cleaning over a decal.
  - Holding nozzle of a pressure washer at an angle different from 90° may lift the decal from the machine.
- Recommended using a safe cement dissolver, **BACK-SET** or similar, to remove hardened concrete.
- It is **NOT** recommended to use chemicals such as:
  - Muriatic Acid
  - Hydrochloric Acid
  - Hydrofluoric Acid
  - Sulfuric Acid
  - Phosphoric Acid
- To prevent build-up of concrete on the machine, use **BODY GUARD** or similar protection wax.

### Filter Cleaning Procedure:

- Remove air filters and blow out with compressed air, **NOT** to exceed 80 PSI.

# SECTION 3 SERVICE

## Hydraulic Schematic for 32 to 34 ft

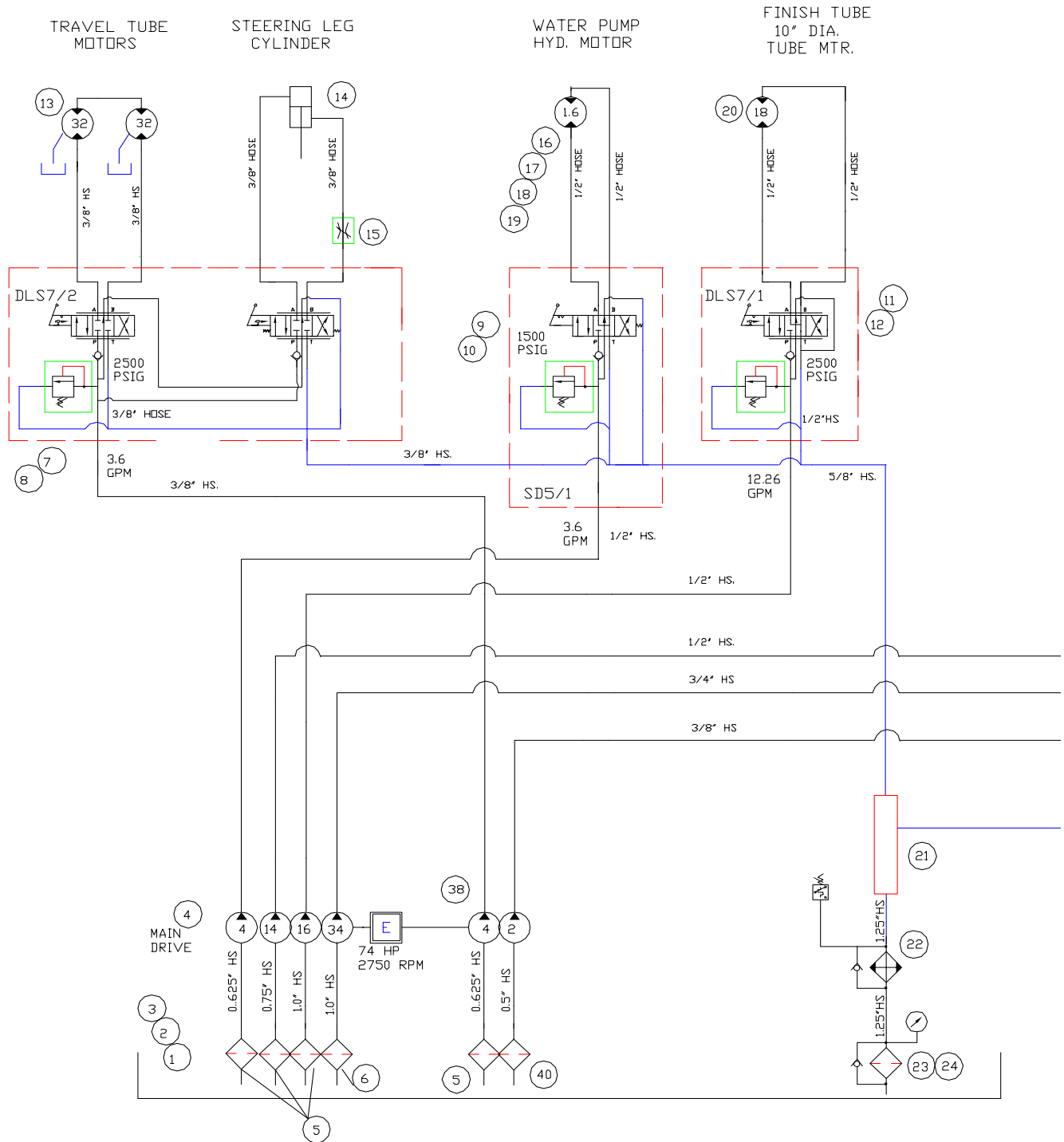

# Hydraulic Schematic for 32 to 34 ft

## SECTION 3 SERVICE

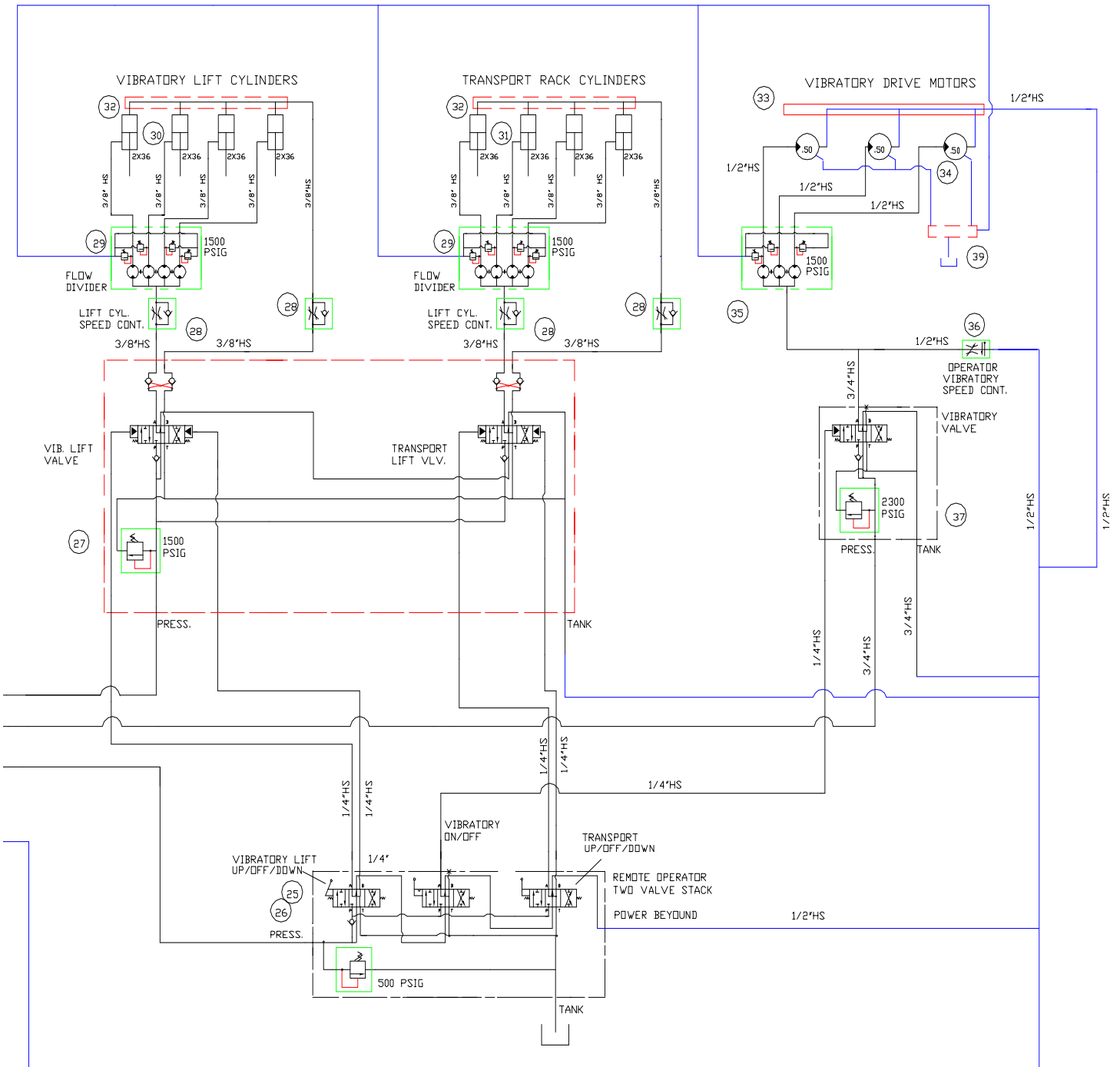

## SECTION 3 SERVICE

## Hydraulic Schematic Parts List for 32 to 34 ft

ITEM	PART #	DESCRIPTION	QTY
1	032960	WELD RING	2
2	032268	FILTER BREATHER ASSEMBLY	2
3	042844	TEMP/LEVEL GAUGE ASSEMBLY	1
4	078133	HYDRAULIC QUAD PUMP	1
5	040073	TMF-10-5 SUCTION STRAINER	4
6	049357	TMF-25-5 SUCTION STRAINER	1
7	040066	TWO VALVE STACK, TRAVEL/STEERING LEG	1
8	040074	CONTROL HANDLE M10X150	2
9	040063	CONTROL VALVE, WATER SPRAY	1
10	055078	CONTROL HANDLE M8X150	1
11	040058	SINGLE VALVE STACK, FINISH TUBE	1
12	040074	CONTROL HANDLE M10X150	1
13	044652	HYDRAULIC TRAVEL MOTORS	2
14	029238	STEERING LEG CYLINDER	1
15	029232	STEERING NEEDLE VALVE	1
16	040065	HYDRAULIC SPRAY MOTOR	1
17	040059	FOOT BRACKET	1
18	040060	COUPLING HALVES	2
19	040061	COUPLING INSERT	1
20	029231	HYDRAULIC FINISH MOTOR	1
21	049358	HEADER MANIFOLD	1
22	077632	HYDRAULIC COOLER	1
-	066143	TEMPERATURE SWITCH	1
-	055127	CONNECTOR, FOR TEMP. SWITCH	1
23	077633	FILTER, RETURN LINE ASSEMBLY	1
24	-	FILTER GAUGE	1
24A	046241	FUEL TANK LEVEL GAUGE	1
24B	029413	RELIEF VALVE, FOR SPRAY	2
24C	047412	THREE WAY BALL VALVE	1
25	077634	THREE STATION PILOT CONTROL VALVE, VIB/RACK LIFT/ TRANSPORT LIFT	1
26	055078	CONTROL HANDLE M8X120	3
27	077635	LIFT/TRANSPORT CYLINDER VALVE STACK	1

## Hydraulic Schematic Parts List for 32 to 34 ft

## SECTION 3 SERVICE

28	049089	FLOW CONTROL VALVES	4
29	077994	FLOW DIVIDER, FOUR SECTION	2
30	049366	VIBRATION LIFT CYLINDER	4
31	068172	TRANSPORT RACK CYLINDER	3
31A	068172-SP	TRANSPORT RACK CYLINDER, ADD. ROD END PORT	1
32	055686	MANIFOLD CYLINDER HEADER	2
33	068171	HEADER MANIFOLD	1
34	049367	VIBRATION MOTOR	3
35	077996	FLOW DIVIDER, THREE SECTION	1
36	050451	VIBRATION BYPASS FLOW CONTROL	1
37	049360	VIBRATION MOTOR CONTROL VALVE	1
38	077637	HYDRAULIC TANDEM GEAR PUMP	1
39	068814	CASE DRAIN TANK HEADER MANIFOLD	1
40	040072	TMF-05-5 SUCTION STRAINER	1

# SECTION 3 SERVICE

## Hydraulic Schematic for 18 to 30 ft

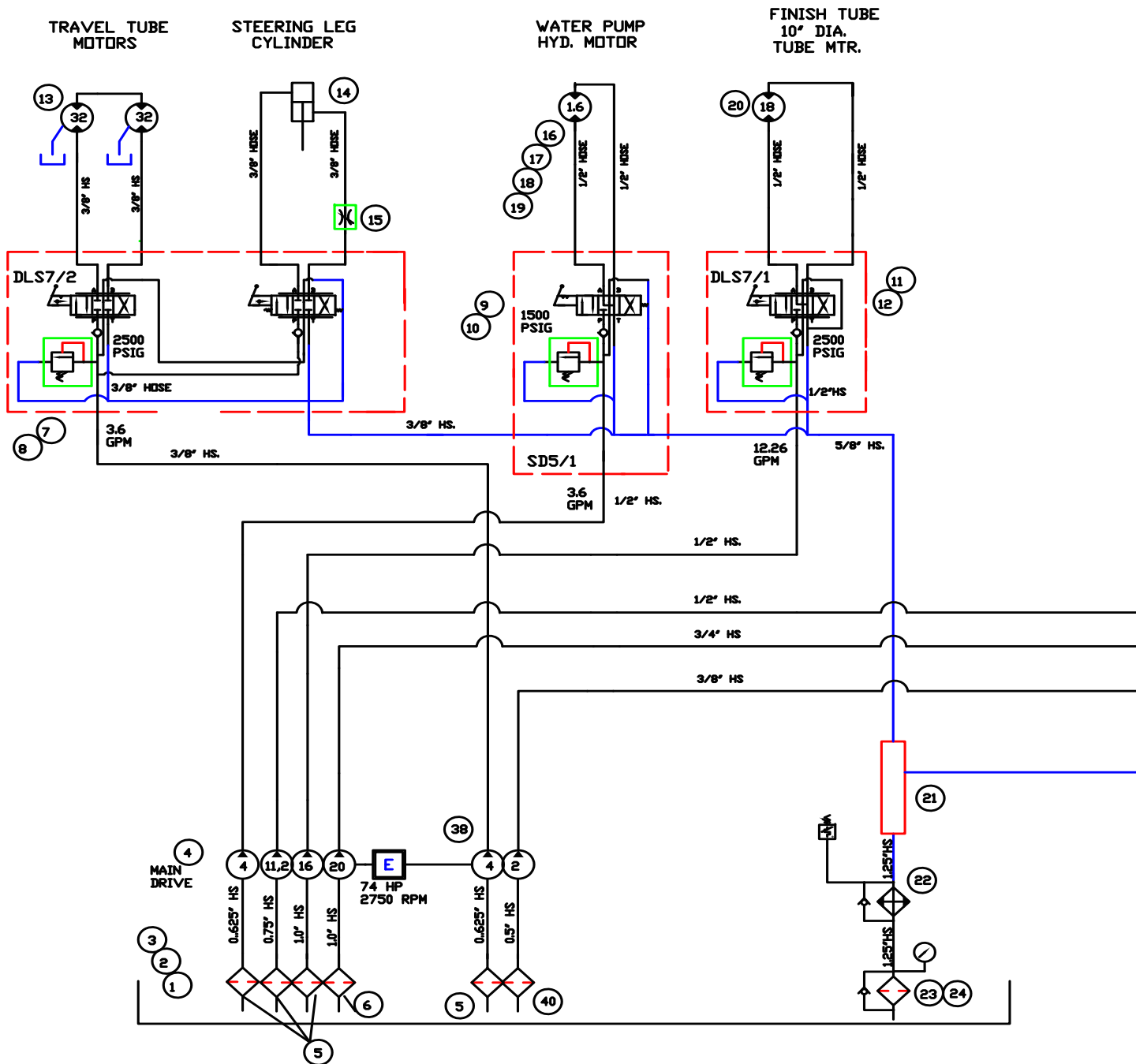

# Hydraulic Schematic for 18 to 30 ft

## SECTION 3 SERVICE

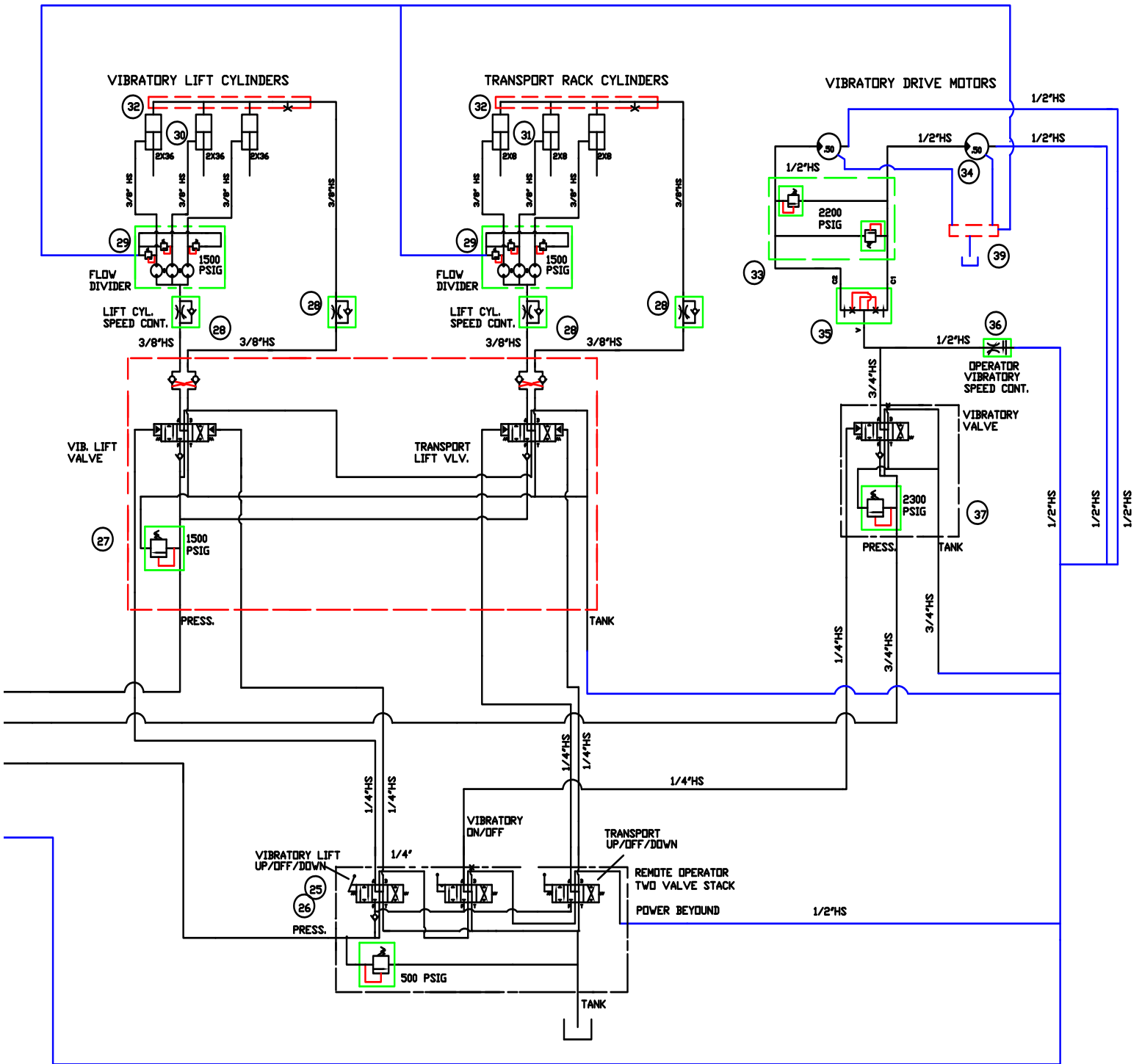

## SECTION 3 SERVICE

## Hydraulic Schematic Parts List for 18 to 30 ft

ITEM	PART #	DESCRIPTION	QTY
1	032960	Weld ring	2
2	032268	Filter Breather assembly	2
3	042844	Temp/Level Gauge assembly	1
4	078133	Hydraulic Quad Pump	1
5	040073	TMF-10-5 Suction Strainer	4
6	049357	TMF-25-5 Suction Strainer	1
7	040066	Two Valve Stack, travel/steering leg	1
8	040074	Control Handle M10x150	2
9	040063	Control Valve, Water Spray	1
10	055078	Control handle M8x150	1
11	040058	Single Valve Stack, finish tube	1
12	040074	Control Handle M10x150	1
13	044652	Hydraulic Travel Motors	2
14	029238	Steering leg Cylinder	1
15	029232	Steering Needle Valve	1
16	040065	Hydraulic Spray motor	1
17	040059	Foot bracket	1
18	040060	Coupling Halves	2
19	040061	Coupling insert	1
20	029231	Hydraulic Finish motor	1
21	049358	Header Manifold	1
22	077632	Hydraulic Cooler	1
-	066143	Temperature Switch	1
-	055127	Connector, for temp. switch	1
23	077633	Filter, Return line assembly	1
24	-	Filter Gauge	1
24A	046241	Fuel Tank level Gauge	1
24B	029413	Relief Valve, for spray	2
24C	047412	Three way ball valve	1
25	077634	Three station pilot control valve, Vib/rack lift/ transport lift	1
26	055078	Control handle M8x120	3
27	077635	Lift/Transport Cylinder Valve Stack	1
28	049089	Flow Control Valves	4
29	077994	Flow Divider, four section	2
30	049366	Vibration lift cylinder	3

## Hydraulic Schematic Parts List for 18 to 30 ft

## SECTION 3 SERVICE

ITEM	PART #	DESCRIPTION	QTY
31	068172	Transport Rack Cylinder	3
32	055686	Manifold Cylinder Header	2
33	068171	Header manifold	1
34	049367	Vibration Motor	2
35	077996	Flow Divider, three section	1
36	050451	Vibration Bypass flow control	1
37	049360	Vibration Motor Control valve	1
38	077637	Hydraulic Tandem Gear pump	1
39	068814	Case drain tank header manifold	1
40	040072	TMF-05-5 Suction Strainer	1

# SECTION 3 SERVICE

## Hydraulic Schematic for 12 to 16 ft

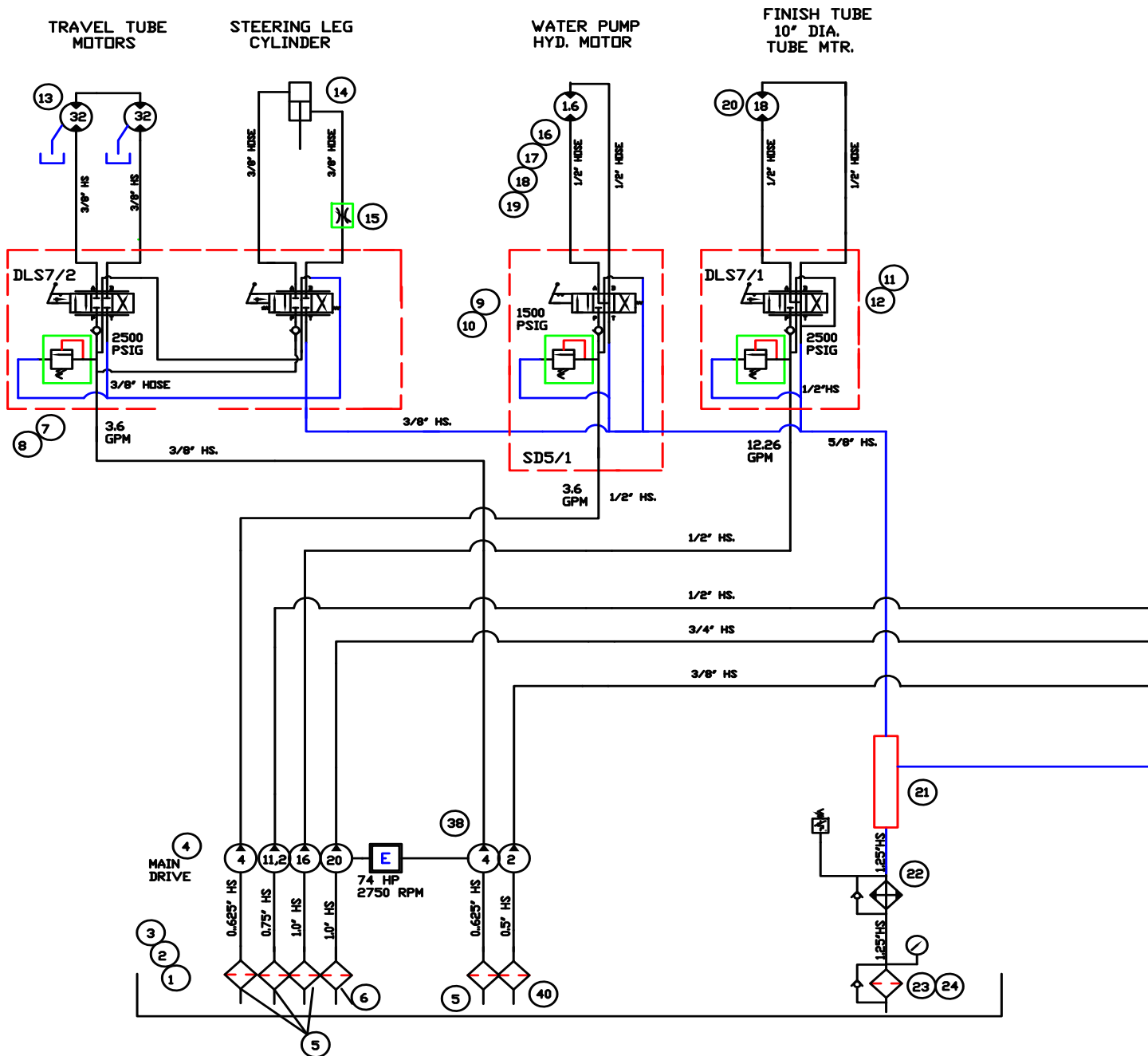

# Hydraulic Schematic for 12 to 16 ft

## SECTION 3 SERVICE

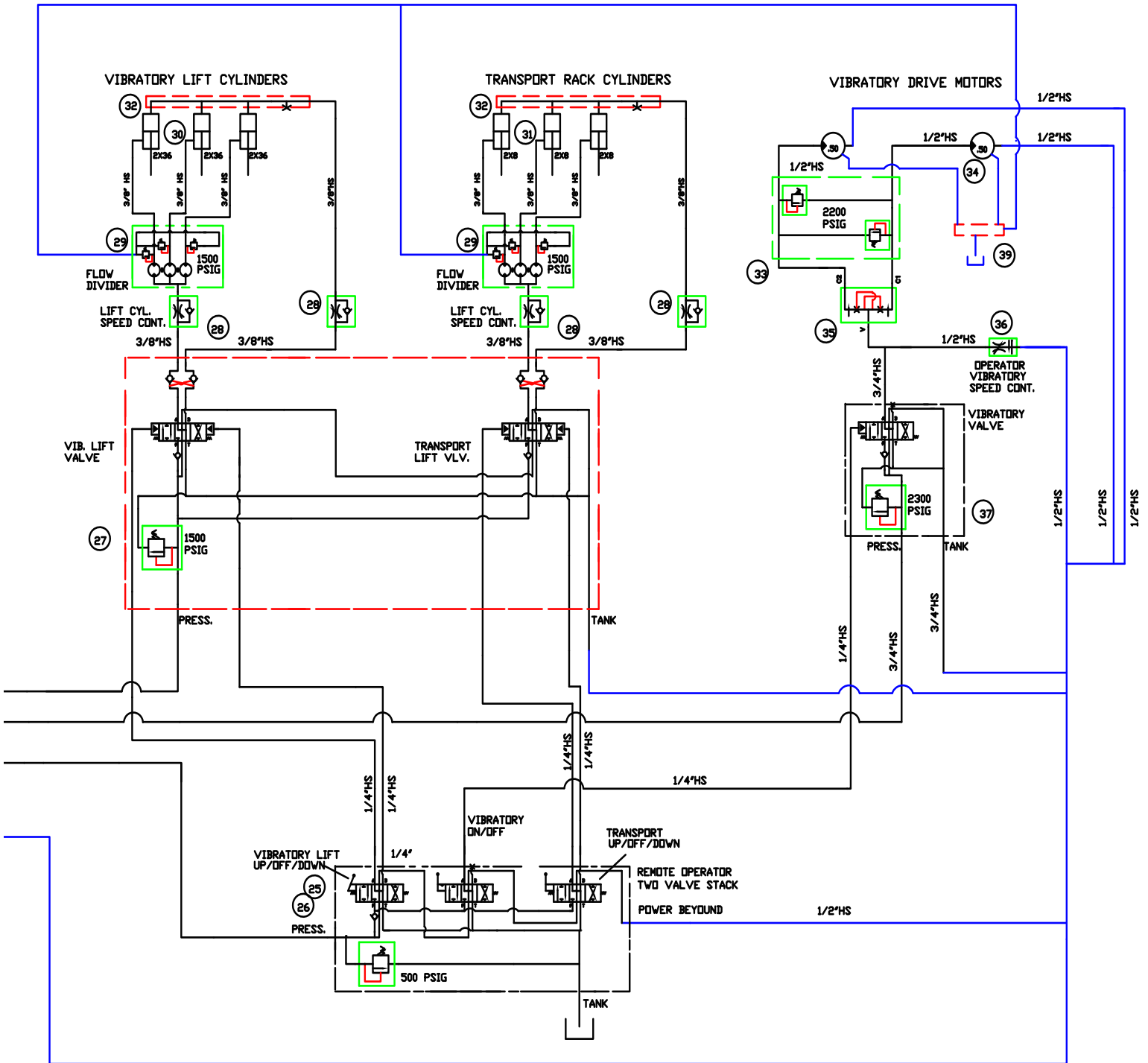

## SECTION 3 SERVICE

## Hydraulic Schematic Parts List for 12 to 16 ft

ITEM	PART #	DESCRIPTION	QTY
1	032960	Weld ring	2
2	032268	Filter Breather assembly	2
3	042844	Temp/Level Gauge assembly	1
4	078133	Hydraulic Quad Pump	1
5	040073	TMF-10-5 Suction Strainer	4
6	049357	TMF-25-5 Suction Strainer	1
7	040066	Two Valve Stack, travel/steering leg	1
8	040074	Control Handle M10x150	2
9	040063	Control Valve, Water Spray	1
10	055078	Control handle M8x150	1
11	040058	Single Valve Stack, finish tube	1
12	040074	Control Handle M10x150	1
13	044652	Hydraulic Travel Motors	2
14	029238	Steering leg Cylinder	1
15	029232	Steering Needle Valve	1
16	040065	Hydraulic Spray motor	1
17	040059	Foot bracket	1
18	040060	Coupling Halves	2
19	040061	Coupling insert	1
20	029231	Hydraulic Finish motor	1
21	049358	Header Manifold	1
22	077632	Hydraulic Cooler	1
-	066143	Temperature Switch	1
-	055127	Connector, for temp. switch	1
23	077633	Filter, Return line assembly	1
24	-	Filter Gauge	1
24A	046241	Fuel Tank level Gauge	1
24B	029413	Relief Valve, for spray	2
24C	047412	Three way ball valve	1
25	077634	Three station pilot control valve, Vib/rack lift/ transport lift	1
26	055078	Control handle M8x120	3
27	077635	Lift/Transport Cylinder Valve Stack	1
28	049089	Flow Control Valves	4
29	077994	Flow Divider, four section	2
30	049366	Vibration lift cylinder	2
31	068172	Transport Rack Cylinder	2

## Hydraulic Schematic Parts List for 12 to 16 ft

## SECTION 3 SERVICE

ITEM	PART #	DESCRIPTION	QTY
32	055686	Manifold Cylinder Header	2
33	068171	N/A	-
34	049367	Vibration Motor	1
35	077996	N/A	-
36	050451	Vibration Bypass flow control	1
37	049360	Vibration Motor Control valve	1
38	077637	Hydraulic Tandem Gear pump	1
39	068814	Case drain tank header manifold	1
40	040072	TMF-05-5 Suction Strainer	1

**SECTION 3  
SERVICE**

**Harness, 23' Gang TRTP Strobe Light**

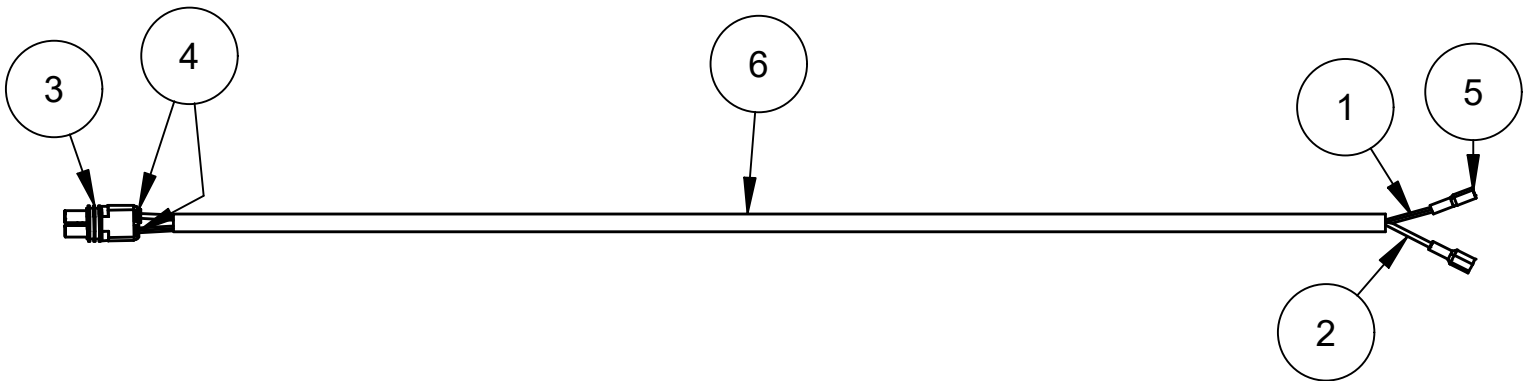

ITEM	PART #	DESCRIPTION	QTY
1	036928	WIRE, 16 AWG RED	21'
2	036931	WIRE, 16 AWG BLACK	21'
3	038641	HOUSING, FEMALE TERM 2 CONTACT	1
4	038648	CAVITY SEAL F/ 16-14 GREY	2
5	039160	SPADE, SMALL FEMALE 18-22 GA INS	2
6	056552	LOOM, 1/4" EASY OPEN WRAP	23'

## Manual Revision Details

## GENERAL INFORMATION

### MANUAL REVISION DETAIL

REVISION #	REVISION DATE	REVISION REFERENCE #	REVISION BY
-	7/23	Initial Release	MK
A	02/26	Updated warranty policy 2026. Add 18-30ft, 12-16ft hyd schematics.	MK



**AEC FACTORY & HEADQUARTERS**

819 S. 5TH STREET  
PARAGOULD, ARKANSAS 72450  
870.236.7751  
800.643.0095 (TOLL FREE (USA ONLY))

**MAILING**

PO BOX 819  
PARAGOULD, ARKANSAS 72451

**ALLENENG.COM**

CONNECT WITH US ON SOCIAL

